



Directional solenoid and pneumatic valves

WARNING!

Variations and modifications of technical features and dimensions are reserved.

WALVOIL S.p.A. also reserves the right to stop production of each and any model listed in the catalogue with no notice.

Copyrights on the text contained herein belong to **WALVOIL S.p.A.** . Partial and full reproductions or copies of this catalogue are forbidden.

WALVOIL IS NOT RESPONSIBLE FOR ANY DAMAGE CAUSED BY AN INCORRECT USE OF THE PRODUCT.

1st EDITION MAY 2010

Technical Specifications

Fluid:best use mineral oil with viscosity ranging between 10 and 200 cSt.

Filter:dirty oil is the main reason for failure and troubles of hydraulic parts and systems.

The table below contains **OLEOSTAR S.p.A.** recommendations about the minimum oil contamination level according to individual specifications of different items. For further safety of your hydraulic equipment and of all valves assembled on it, we either recommend use suction filters (rather than return filters) or separated filter lines.

TYPE OF EQUIPMENT - TYPE OF VALVE	CONTAMINATION LEVEL According to ISO 4406
<ul style="list-style-type: none"> - Heavy duty equipment - Equipment running at 210-350 bar (3050-5100 psi) working pressure - Equipment using proportional controls - Equipment with high frequency cycles 	-/16/13
<ul style="list-style-type: none"> - Equipment running up to 210 bar (3050 psi) working pressure - Spool-type valves - Valves with calibrated ports 	-/18/14
<ul style="list-style-type: none"> - Equipment running at low working pressure - Pilot plants and equipment - Equipment with low frequency cycles 	-/19/15

Installation:make sure to provide suitable seal lubrication with clean oil before screwing the cartridge on the valve body .

Also make sure to screw the cartridge manually in to reach against the seals in the valve body.

Material:internal components made out of high grade steel duly treated and fabricated.

For more information please ask our technical office .

Working temperature:min. -25°C (-13°F) max. 90°C (194°F) with standard BUNA N seals

min. -20°C (-4°F) max. 200°C (392°F) with optional VITON seals

Rating diagrams:all rating diagrams of this catalogue are measured with mineral oil of 46 cSt viscosity at 40° (104°F)

temperature.

All drawings dimensions are defined as $\frac{\text{mm}}{\text{in}}$

Hydraulic diagram	Type	Description	Maximum flow up to		Maximum pressure		Page
			l/min	US gpm	bar	psi	
	VSE /P /2	2 way electric valves, pilot-operated, poppet type	150	40	350	5100	11
	EC08B		40	10.5			

Hydraulic diagram	Type	Description	Maximum flow up to		Maximum pressure		Page
			l/min	US gpm	bar	psi	
	EC08A	2 way electric valves, pilot-operated, poppet type	20	5.3	210	3050	15

Hydraulic diagram	Type	Description	Maximum flow up to		Maximum pressure		Page
			l/min	US gpm	bar	psi	
	VE /B 14 (38/VP)	2 way electric valves, pilot-operated, poppet type	20	5.3	210	3050	17
	VE /B/RO 14 (38/VP)						

Hydraulic diagram	Type	Description	Maximum flow up to		Maximum pressure		Page
			l/min	US gpm	bar	psi	
	VE /B	2 way electric valves, pilot-operated, poppet type	160	42	350	5100	17
	VE /B/RO	2 way electric valves, pilot-operated, poppet type, bolt mounting	40	10.5			

Hydraulic diagram	Type	Description	Maximum flow up to		Maximum pressure		Page
			l/min	US gpm	bar	psi	
	VE/B 14/TCW/VG	2 way electric valves, direct acting reinforced poppet type	10	2.6	210	3050	25

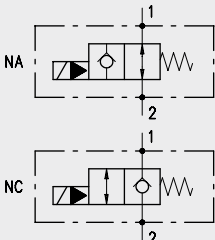
Hydraulic diagram	Type	Description	Maximum flow up to		Maximum pressure		Page
			l/min	US gpm	bar	psi	
	EC..A	2 way electric valves, pilot operated poppet type	150	40	350	5100	27

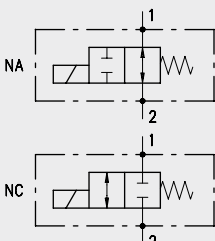
Hydraulic diagram	Type	Description	Maximum flow up to		Maximum pressure		Page
			l/min	US gpm	bar	psi	
	EE..A	2 way electric valves, direct acting, spool type	40	10.5	210	3050	31

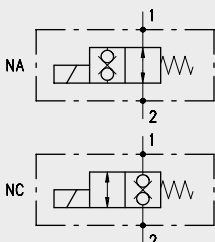
Hydraulic diagram	Type	Description	Maximum flow up to		Maximum pressure		Page
			l/min	US gpm	bar	psi	
	EW08A	2 way electric valves, direct acting, double sealing poppet type	10	2.6	210	3050	35
	EW10A/20 (NC)		25	6.6			
	EW10B/10 (NA)		30	8			
	EW12B/10 (NA)		50	13			
	EW12C/20 (NC)						

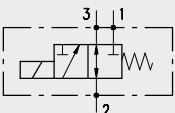
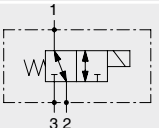
Hydraulic diagram	Type	Description	Maximum flow up to		Maximum pressure		Page
			l/min	US gpm	bar	psi	
	EJ..A/1	electric valve 3 ways, 2 positions, spool type	40	10.5	210	3050	41
	EJ08B/1		12	3.2			
	EJ08M/1		23**	6**	250**	3600**	

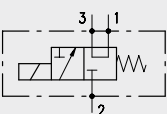
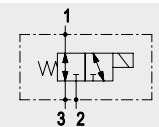
Hydraulic diagram	Type	Description	Maximum flow up to		Maximum pressure		Page
			l/min	US gpm	bar	psi	
	EJ..A/2	electric valve 3 ways, 2 positions, spool type	40	10.5	210	3050	47
	EJ..B/2		20	5.3			
	EJ08M/2		25**	6.6**	250**	3600**	

**see the performance limit diagram

Index

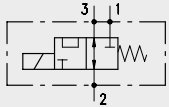
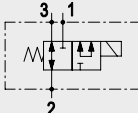
Hydraulic diagram	Type	Description	Maximum flow up to		Maximum pressure		Page
			l/min	US gpm	bar	psi	
	EJ..A/3	Electric valve 3 ways, 2 positions, spool type	30	8	210	3050	55
	EJ08B/3		12	3.2			
	EJ08M/3		24**	6.3**	250**	3600**	

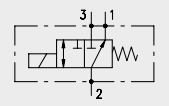
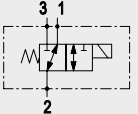
Hydraulic diagram	Type	Description	Maximum flow up to		Maximum pressure		Page
			l/min	US gpm	bar	psi	
	EJ..A/4	Electric valve 3 ways, 2 positions, spool type	40	10.5	210	3050	61
	EJ..B/4		20	5.3			
	EJ..M/4		25**	6.6**	250**	3600**	

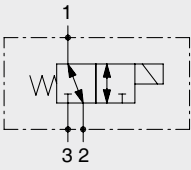
Hydraulic diagram	Type	Description	Maximum flow up to		Maximum pressure		Page
			l/min	US gpm	bar	psi	
	EJ..M/5	Electric valve 3 ways, 2 positions, spool type	25**	6.6**	250**	3600**	67

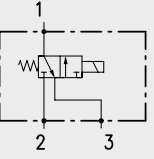
Hydraulic diagram	Type	Description	Maximum flow up to		Maximum pressure		Page
			l/min	US gpm	bar	psi	
	EJ08/F2	Electric valve 3 ways, 2 positions, spool type special for low pressure	12	3.2	50	725	69

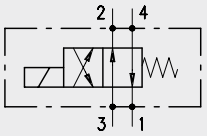
Hydraulic diagram	Type	Description	Maximum flow up to		Maximum pressure		Page
			l/min	US gpm	bar	psi	
	ER..A/1	Electric valve 4 ways, 2 positions, spool type	40	10.5	210	3050	71
	ER..B/1		20	5.3			
	ER..M/1		40	10.5			

**see the performance limit diagram

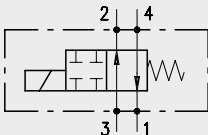
Hydraulic diagram	Type	Description	Maximum flow up to		Maximum pressure		Page
			l/min	US gpm	bar	psi	
	ER..A/2	Electric valve 4 ways, 2 positions, spool type	40	10.5	210	3050	77
	ER..B/2		20	5.3			
	ER..M/2		45	12			

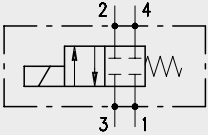
Hydraulic diagram	Type	Description	Maximum flow up		Maximum pressure		Page
			l/min	US gpm	bar	psi	
	ER..A/3	Electric valve 4 ways, 2 positions, spool type	40	10.5	210	3050	83
	ER..B/3		20	5.3			
	ER..M/3		40	10.5			

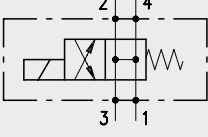
Hydraulic diagram	Type	Description	Maximum flow up		Maximum pressure		Page
			l/min	US gpm	bar	psi	
	ER..A/4	Electric valve 4 ways, 2 positions, spool type	40	10.5	210	3050	89
	ER..B/4		20	5.3			
	ER..M/4		40	10.5			

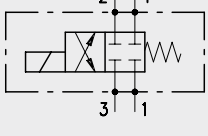
Hydraulic diagram	Type	Description	Maximum flow up		Maximum pressure		Page
			l/min	US gpm	bar	psi	
	ER..A/5	Electric valve 4 ways, 2 positions, spool type	40	10.5	210	3050	95
	ER..M/5						

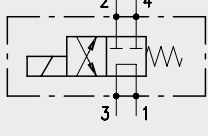
Hydraulic diagram	Type	Description	Maximum flow up		Maximum pressure		Page
			l/min	US gpm	bar	psi	
	ER..A/6	Electric valve 4 ways, 2 positions, spool type	40	10.5	210	3050	101
	ER..M/6						

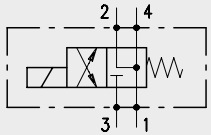
Hydraulic diagram	Type	Description	Maximum flow up to		Maximum pressure		Page
			l/min	US gpm	bar	psi	
	ER..A/7	Electric valve 4 ways, 2 positions, spool type	40	10.5	210	3050	105
	ER..M/7						

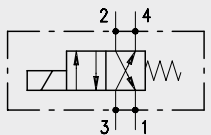
Hydraulic diagram	Type	Description	Maximum flow up to		Maximum pressure		Page
			l/min	US gpm	bar	psi	
	ER..A/8	Electric valve 4 ways, 2 positions, spool type	40	10.5	210	3050	109
	ER..M/8		35	9.2			

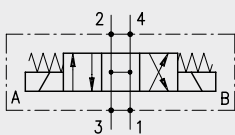
Hydraulic diagram	Type	Description	Maximum flow up to		Maximum pressure		Page
			l/min	US gpm	bar	psi	
	ET..A/1	Electric valve 4 ways, 3 positions, spool type	90	24	210	3050	113
	ET..B/1		20	5.3			
	ET..M/1		40	10.5			

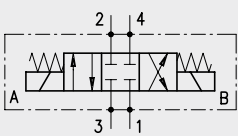
Hydraulic diagram	Type	Description	Maximum flow up to		Maximum pressure		Page
			l/min	US gpm	bar	psi	
	ET..A/2	Electric valve 4 ways, 3 positions, spool type	75	20	210	3050	121
	ET..B/2		20	5.3			
	ET..C/2		8	2			
	ET..F/2		10	2.6			
	ET..M/2		40	10.5			

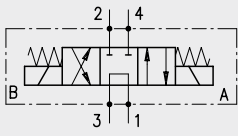
Hydraulic diagram	Type	Description	Maximum flow up to		Maximum pressure		Page
			l/min	US gpm	bar	psi	
	ET..A/3	Electric valve 4 ways, 3 positions, spool type	40	10.5	210	3050	131
	ET..B/3		20	5.3			
	ET..M/3		15	4			

Hydraulic diagram	Type	Description	Maximum flow up to		Maximum pressure		Page
			l/min	US gpm	bar	psi	
	ET..A/4	Electric valve 4 ways, 3 positions, spool type	40	10.5	210	3050	137
	ET..B/4		20	5.3			
	ET..C/4		8	2			
	ET..M/4		40	10.5			

Hydraulic diagram	Type	Description	Maximum flow up to		Maximum pressure		Page
			l/min	US gpm	bar	psi	
	VSE /P /2 NC PNEUMATIC OPERATED	Pneumatic valves, pilot operated, poppet type	150	40	350	5100	145

Hydraulic diagram	Type	Description	Maximum flow up to		Maximum pressure		Page
			l/min	US gpm	bar	psi	
	VSE /P /2 NA PNEUMATIC OPERATED	Pneumatic valves, pilot operated, poppet type	150	40	350	5100	149

Coils

Introduction..... pag.153
 Coil BE.....pag.154
 Coil BT.....pag.155
 Coil BE-EC36pag.157
 Coil BIN 19.....pag.158
 Coil BIN 22.....pag.159
 Coil BCpag.160

Solenoid Connectors

Introduction, solenoid connectors CC-CA, CL and CP pag.162

Adjustments

Optional adjustments..... pag.163

Valves Bodies

2 Way bodies pag.164
 3 Way bodies pag.166
 4 Way bodies pag.168
 How to order valves with bodies pag.170

Cavities, tool and tap

2 Way "SAE" cavity pag.171
 3 Way "SAE" cavity pag.172
 4 Way "SAE" cavity pag.173
 Cavity VSE/P/2/70..... pag.174
 Cavity VSE/P/2/150 pag.175

Operation

With the NA (normally opened) valve version, the oil flow is free from 1 to 2 and vice versa when the solenoid is dropped-out. When the solenoid is energized the flow is stopped from 2 to 1 and is free in the opposite direction.

With the NC (normally closed) valve version, the oil flow is stopped from 2 to 1 and is free from 1 to 2 when the solenoid is dropped out. When the solenoid is energized the flow is free both from 1 to 2 and vice versa.

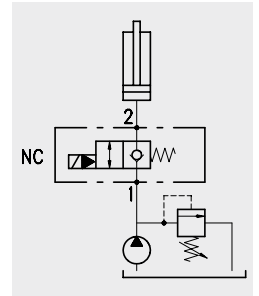

Performance

Body valves

Type	Maximum flow		Maximum pressure		Solenoids**	*Oil leaks from 2 to 1	Weight		Cavities and tools
	l/min	US gpm	bar	psi			kg	lb	
VSE/P/2-70	70	18	350	5100	BT see page 155	0.25 cm ³ /min. - 15x10 ⁻³ in ³ /min. (5 drops) at 210 bar - 3050 psi	0,27	0.59	See cavity VSE/P/2-70 page 174
VSE/P/2-150	150	40					0,36	0.79	See cavity VSE/P/2-150 page 175

*with oil viscosity of 46 cst

Cartridges

Type	Maximum flow		Maximum pressure		Solenoids**	*Oil leaks from 2 to 1	Weight		Cavities and tools
	l/min	US gpm	bar	psi			kg	lb	
EC08B	40	10.5	350	5100	BT see page 155	0.10 cm ³ /min. - 61x10 ⁻⁴ in ³ /min. (2 drops) a 210 bar - 3050 psi	0,12	0.26	See cavity SAE 8-2 page 171

*with oil viscosity of 46 cst

**NOTE: BT...RAC solenoids and special connector should be strictly used with the NA version powered by AC current

Dimensions and hydraulic circuit

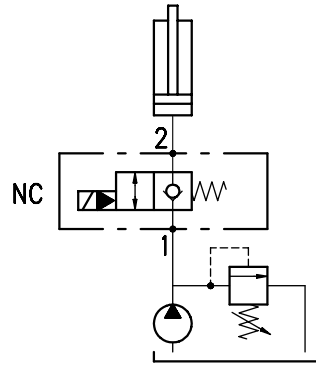
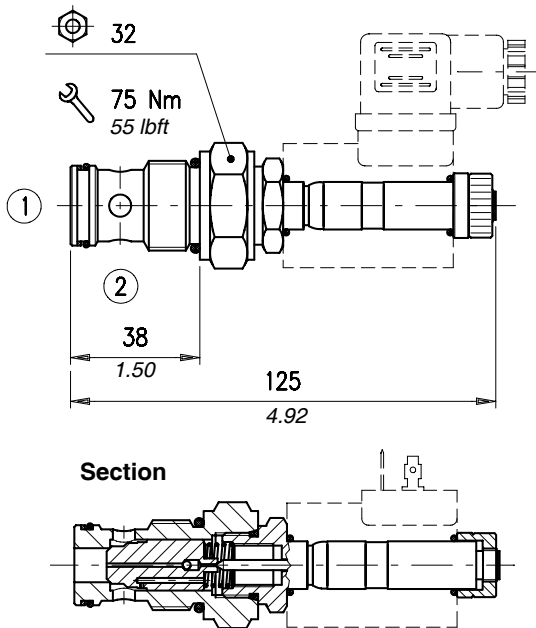

Rating diagrams

Typical pressure drop vs. flow characteristics

VSE/P/2 70/NA

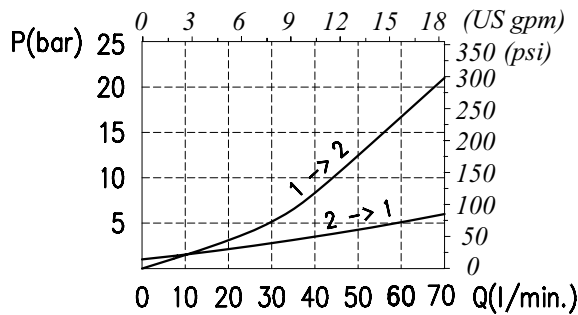

Typical pressure drop vs. flow characteristics

VSE/P/2 70/NC

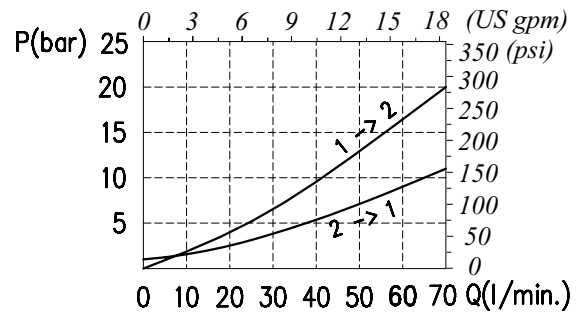

Order code

VSE / P / 2-70 / □

Assembly scheme

NA Normally opened
NC Normally closed

Dimensions and hydraulic circuit

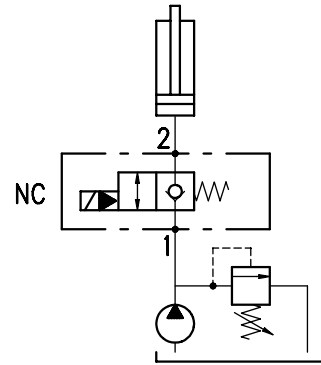
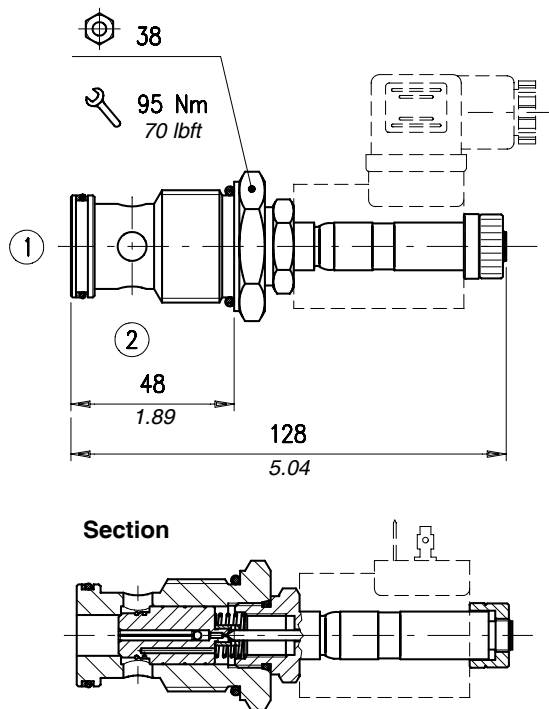

Rating diagrams

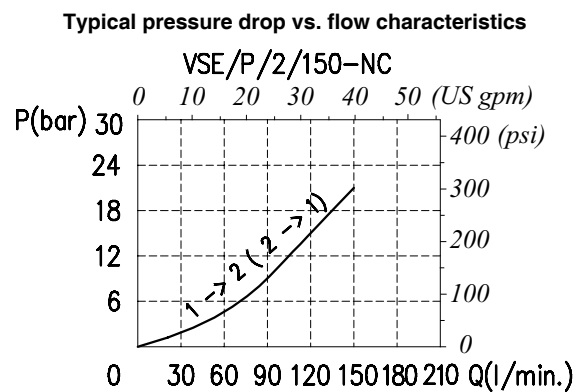
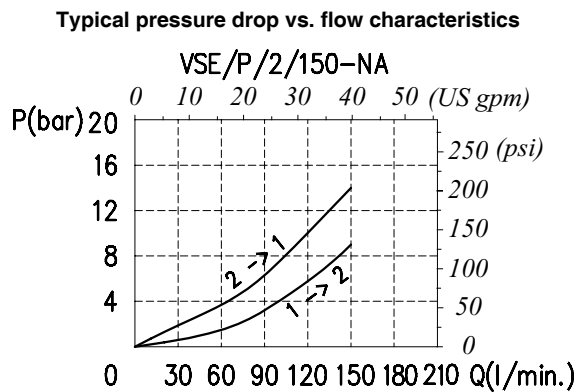

Order code

VSE / P / 2-150 / □

Assembly scheme

NA Normally opened
NC Normally closed

Dimensions and hydraulic circuit

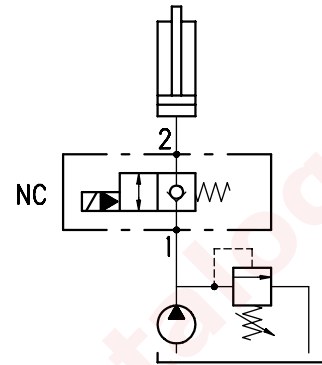
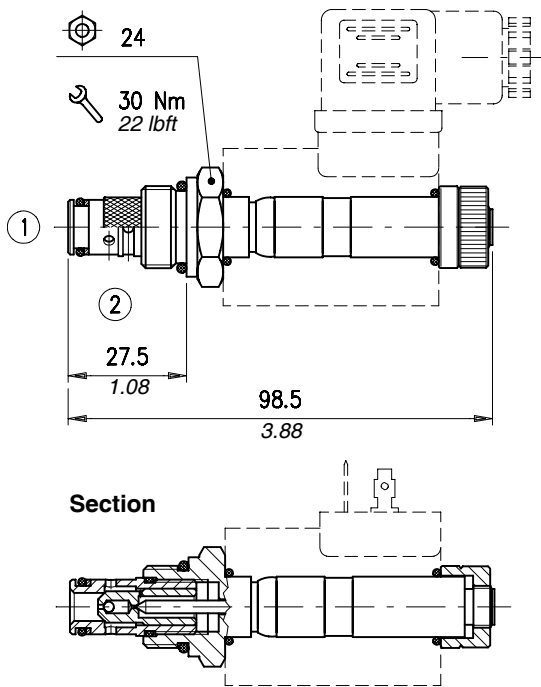

Rating diagrams

Typical pressure drop vs. flow characteristics

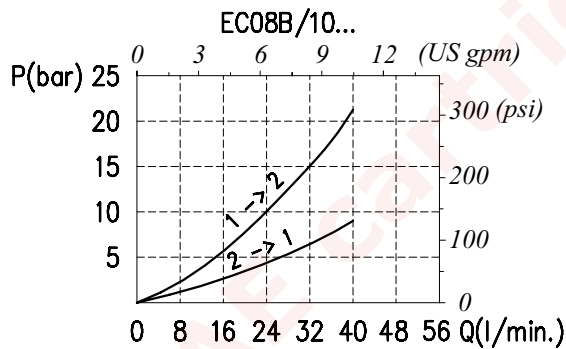

Typical pressure drop vs. flow characteristics

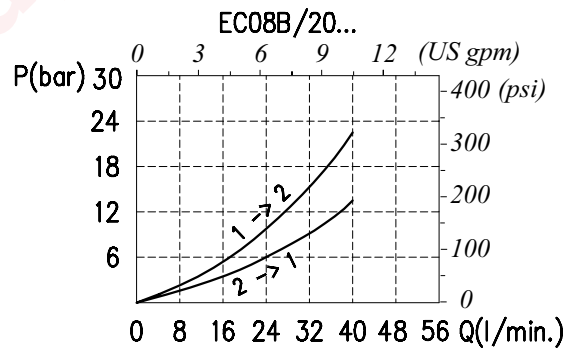

Order code

EC 08B / □ -0 -□ -□

Assembly scheme

- 1) NA Normally opened
- 2) NC Normally closed

Manual override option

(see page 163)

- N) No emergency
- P) Button
- T) Screw

Seals

- B) Buna
- V) Viton

Operation

With the NA (normally Opened) valve version and dropped out solenoid, the oil flow is free from 2 to 1 and is restricted by a 0,4mm (0.016 in) large hole in the opposite direction from 1 to 2. When the solenoid is energized the flow is stopped from 2 to 1 and is free from 1 to 2.

With the NC (normally closed) valve version and dropped out solenoid, the oil flow is stopped from 2 to 1 and is free from 1 to 2. When the solenoid is energized the flow is free from 2 to 1 and is restricted by a 0,4 mm (0.016 in) large hole in the opposite direction (from 1 to 2).

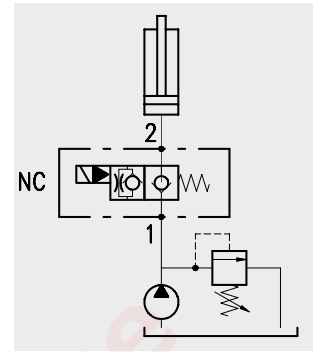

Performance

Cartridges

Type	Maximum flow		Maximum pressure		Solenoids	*Oil leaks from E to U	Weight		Cavities and tools
	l/min	US gpm	bar	psi			kg	lb	
EC08A	20	5.3	210	3050	BE see page 154	0.10 cm ³ /min. - 61x10 ⁻⁴ in ³ /min. (2 drops) at 210 bar - 3050 psi	0,12	0.26	see cavity SAE 8-2 page 171

*With oil viscosity of 46 cst

Dimensions and hydraulic circuit

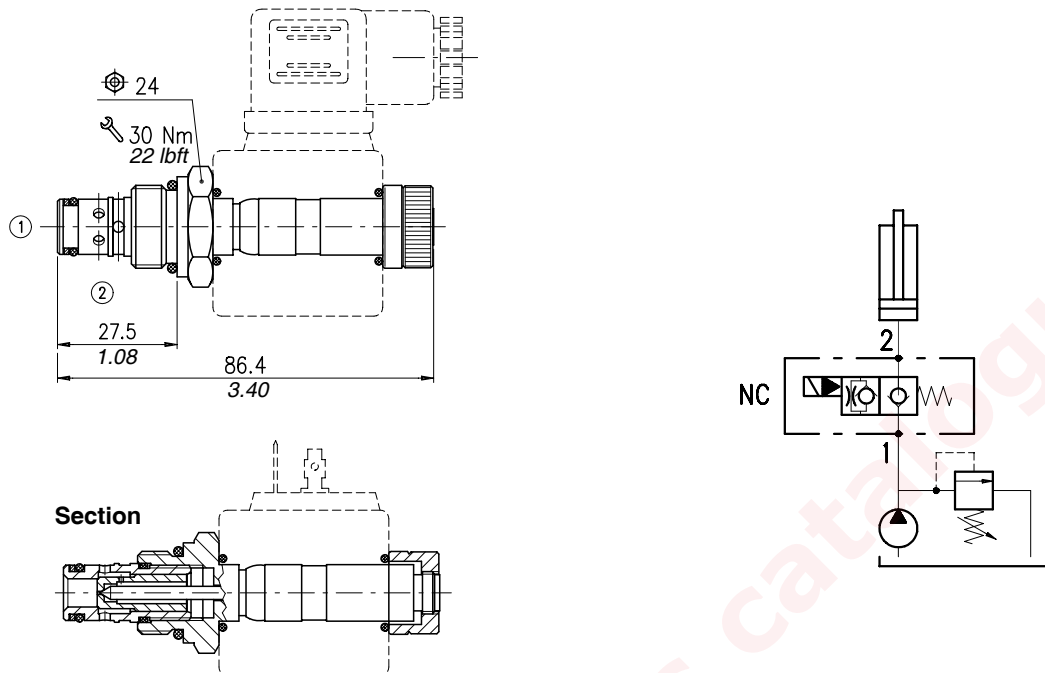

Rating diagrams

Typical pressure drop vs. flow characteristics

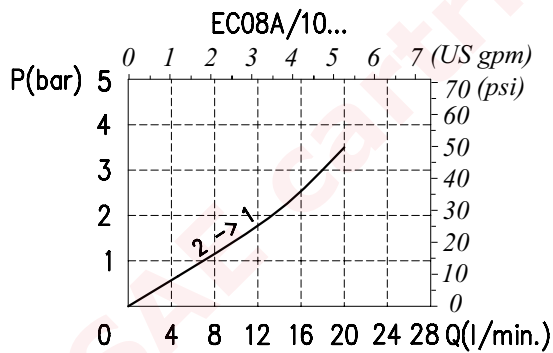

Typical pressure drop vs. flow characteristics

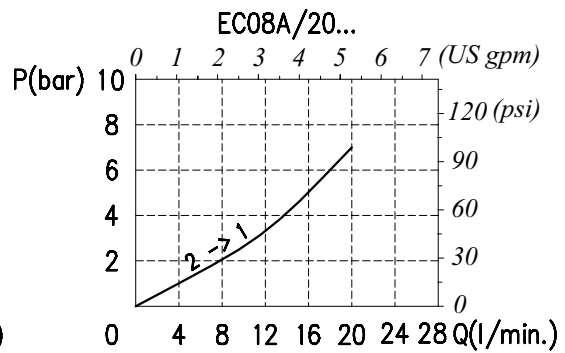

Order code

EC 08A / □ -0 -□ -□

Assembly scheme

1) NA Normally opened
2) NC Normally closed

Manual override option
(see page 163)

N) No emergency
P) Button
T) Screw

Seals

B) Buna
V) Viton

Operation

With the NA (normally opened) valve version and dropped out solenoid, the oil flow is free from E to U and is restricted by a 0.4 mm -0.016 in- large hole in the opposite direction. When the solenoid is energized the flow is stopped from E to U and is free from U to E.

With the NC (normally closed) valve version and dropped out solenoid, the oil flow is stopped from E to U and is free from U to E. When the solenoid is energized the flow is free from E to U and is restricted by a 0.4 mm -0.016 in- large hole in the opposite direction.

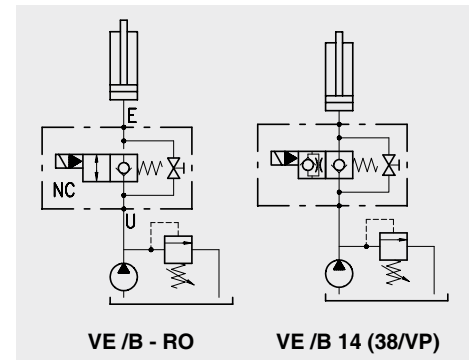

Performance

Body valves

Type	Maximum flow		Maximum pressure		Solenoids	*Oil leaks from E to U	Weight		Cartridge used
	l/min	US gpm	bar	psi			kg	lb	
VE / B 14 (38/VP)	20	5.3	210 (both with aluminium and steel body)	3050	BE see page154	0.10 cm ³ /min. - 61x10 ⁻⁴ in ³ /min. (2 drops) at 210 bar - 3050 psi	0,32	0.70	EC08A see page 16
							aluminium		
							0,69	1,52	
VE/B 38	40	10.5	210	3050	BT see page 155		0,34	0.75	EC08B see page 14
							aluminium		
							0,71	1.56	
VE/B 12	60	16	210	3050	BT see page 155		0,78	1.72	VSE / P /2-70 see page 12
							aluminium		
							1,59	3.50	
VE/B 34	75	20	210 aluminium body	3050 aluminium body	BT see page 155		0,76	1.67	VSE / P /2-70 see page 12
			350 steel body	5100 steel body		1,55	3.42		
			steel	steel					
VE/B 100	160	42	210	3050	BT see page 155	1,15	2.53	VSE / P /2-150 see page 13	
						aluminium			
						2,45	5.40		
VE/B/RO 38	40	10.5	210	3050	BT see page 155	0,41	0.90	EC08B see page 14	
						aluminium			
						0,79	1.74		
VE / B /RO 14 (38/VP)	20	5.3	210 (both with aluminium and steel body)	3050	BE see page154	0,39	0.86	EC08A see page 16	
						aluminium			
						0,76	1.67		

*with oil viscosity of 46 cst

Type VE / B 14 (38/VP)

2 way electric valves,
pilot operated, poppet type

Dimensions and hydraulic circuit

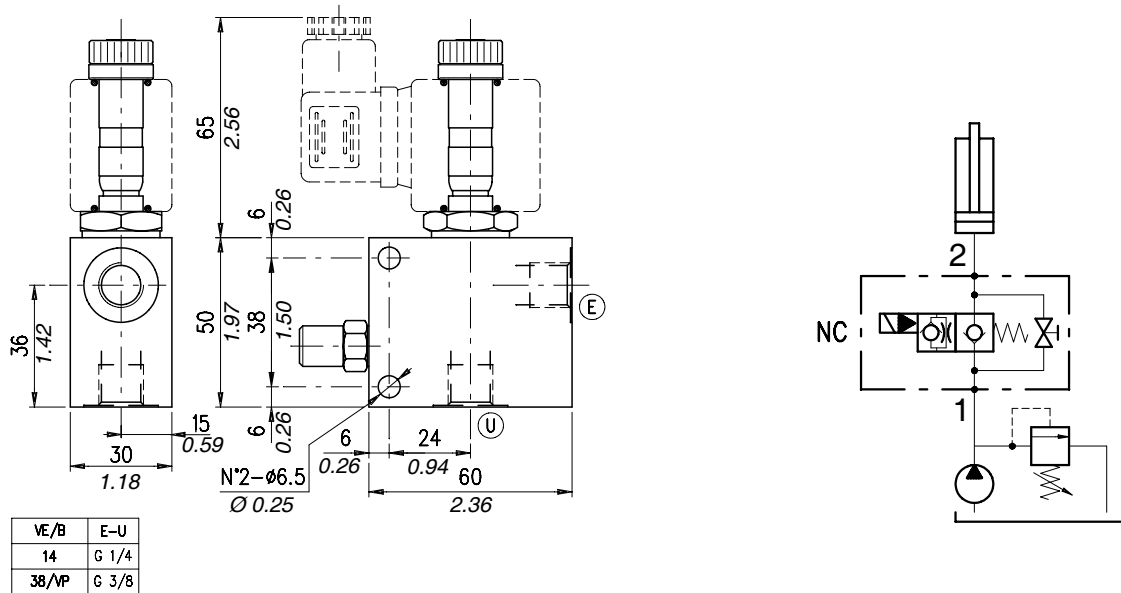

Rating diagrams

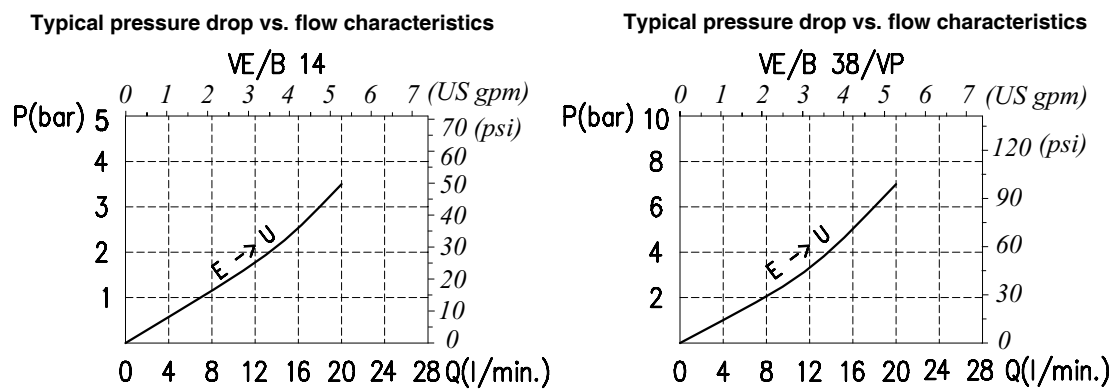

Order code

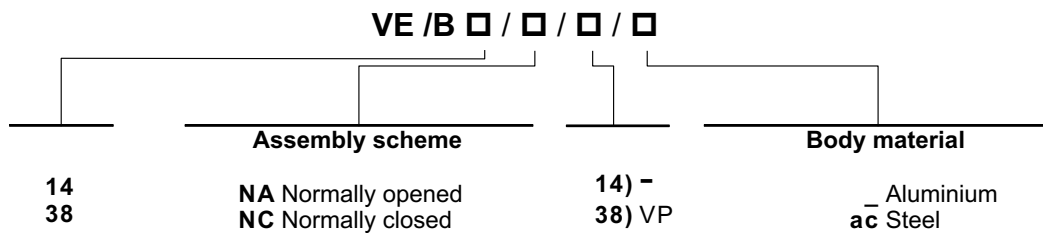

Dimensions and hydraulic circuit

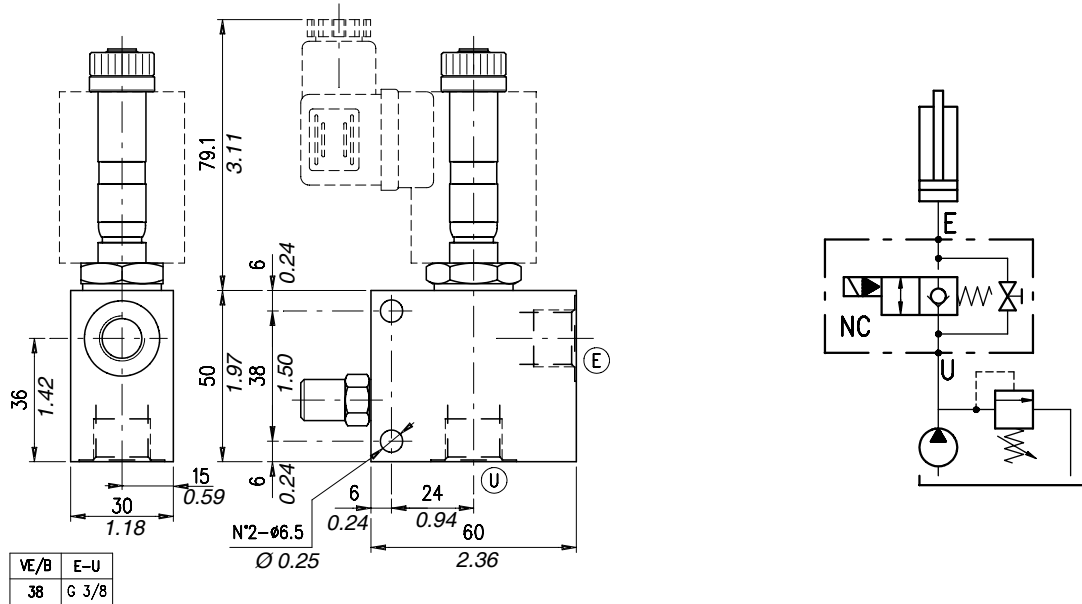

Rating diagrams

Typical pressure drop vs. flow characteristics

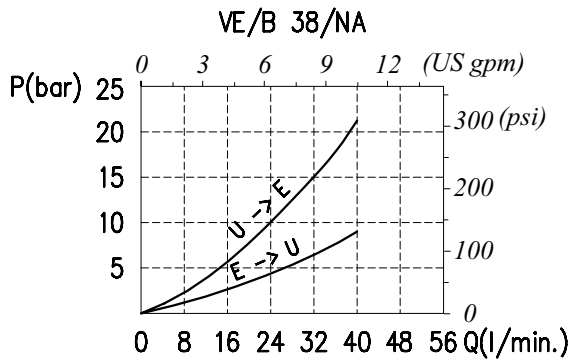

Typical pressure drop vs. flow characteristics

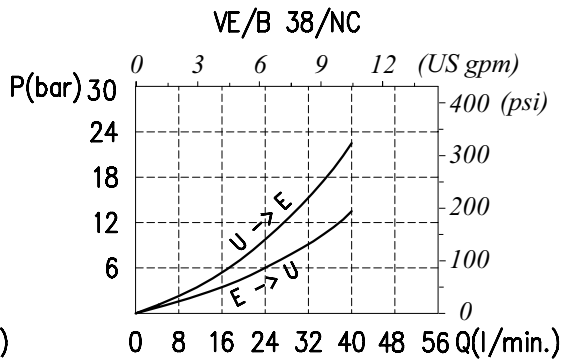

Order code

VE / B / 38 / □ / □

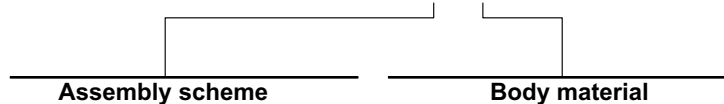

NA Normally opened
NC Normally closed

_ Aluminium
ac Steel

Dimensions and hydraulic circuit

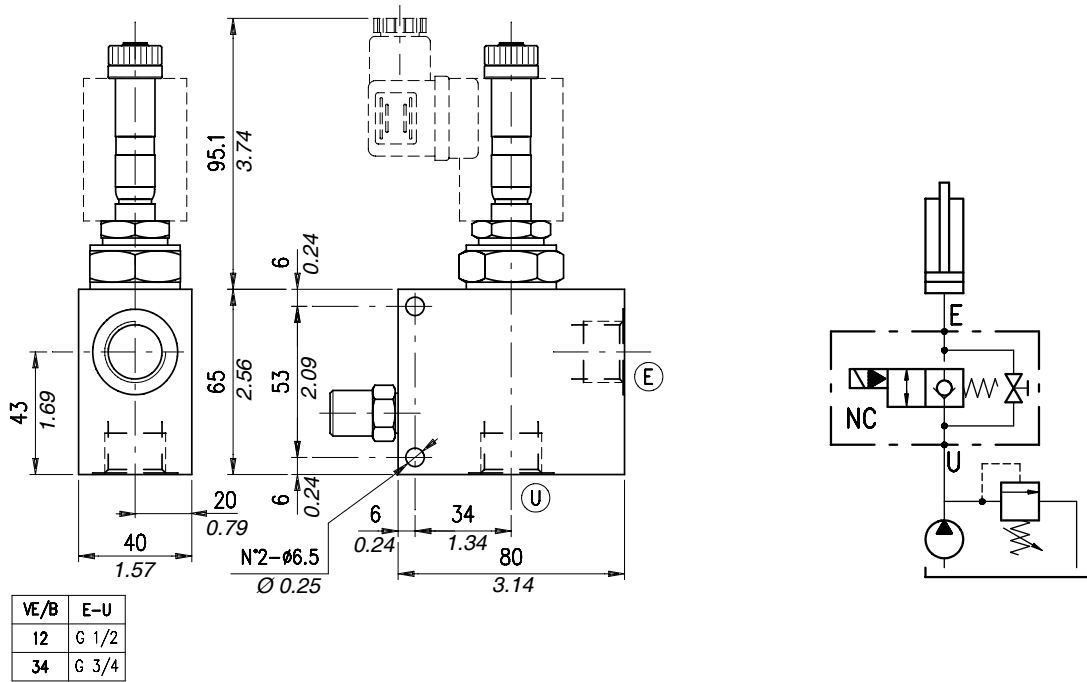

Rating diagrams

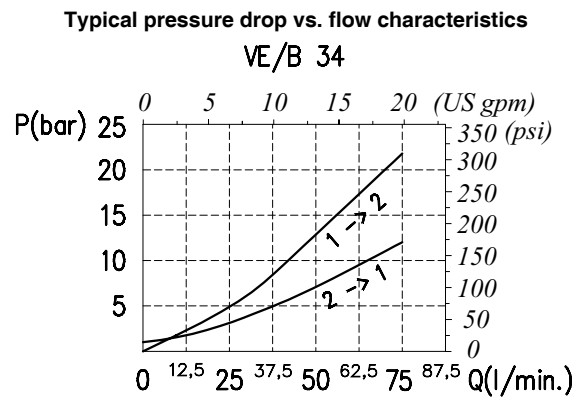
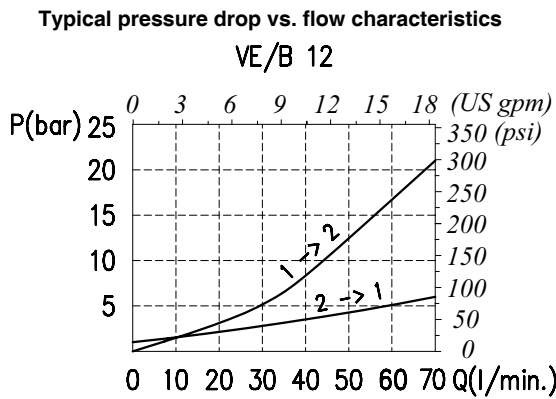

Order code

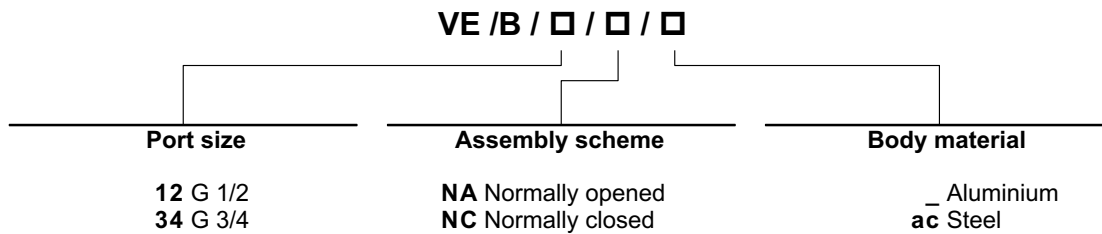

Dimensions and hydraulic circuit

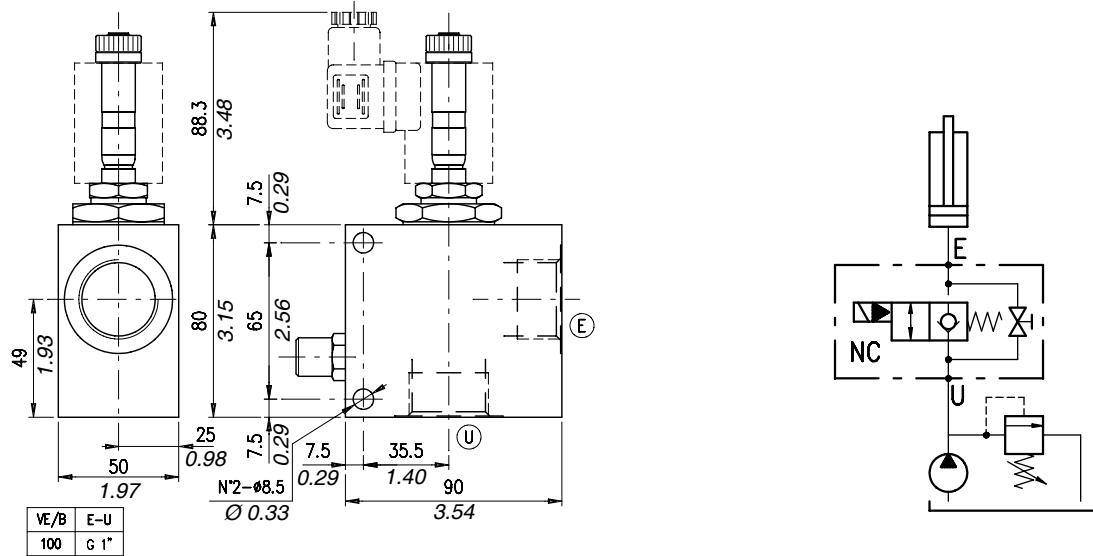

Rating diagrams

Typical pressure drop vs. flow characteristics

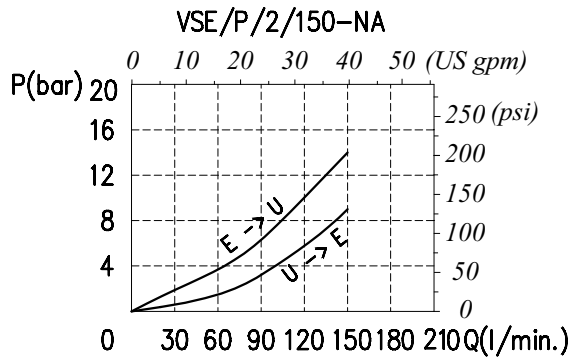

Typical pressure drop vs. flow characteristics

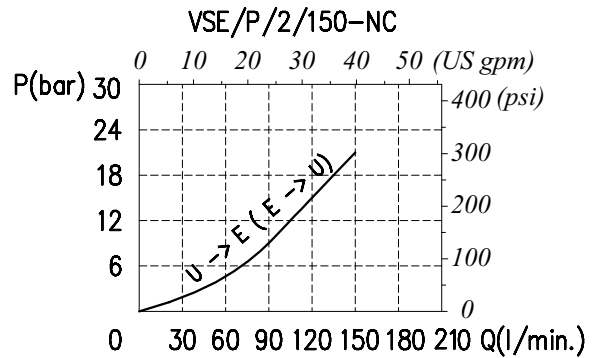

Order code

VE / B / 100 / □ / □

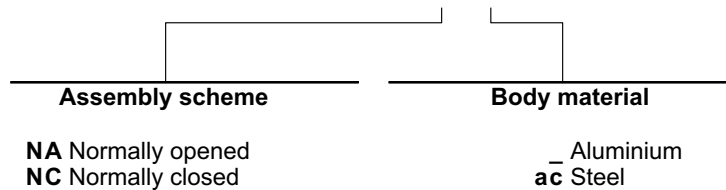

Dimensions and hydraulic circuit

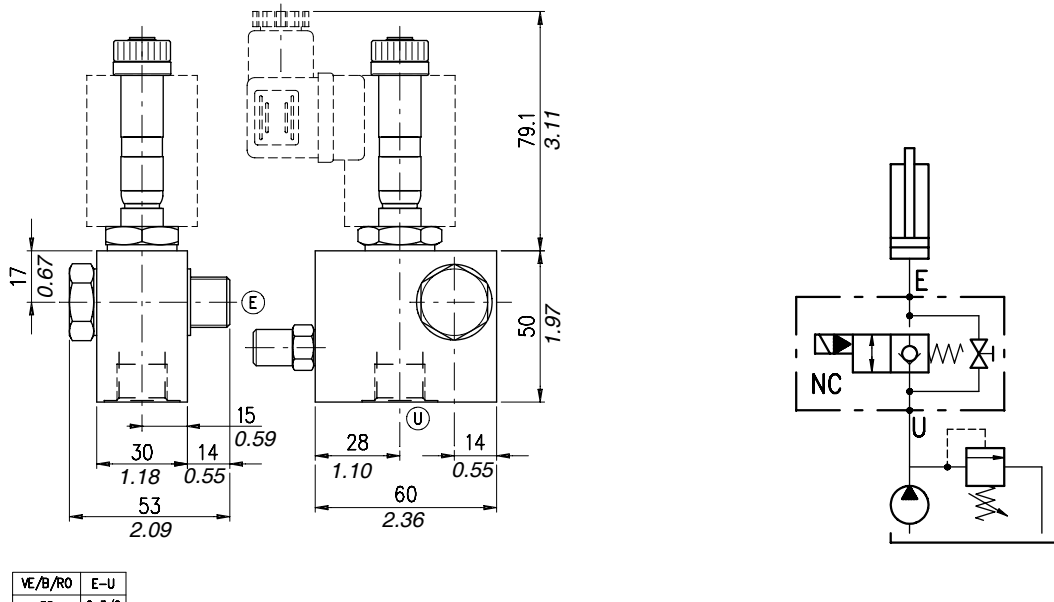

Rating diagrams

Typical pressure drop vs. flow characteristics

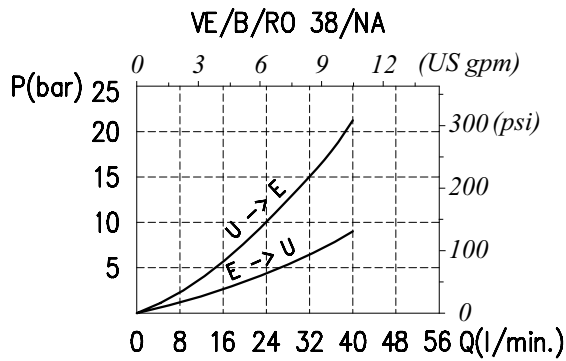

Typical pressure drop vs. flow characteristics

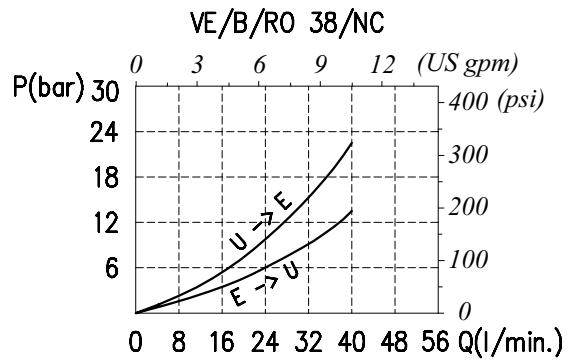

Order code

VE / B / RO / 38 / □ / □

Assembly scheme

Body material

NA Normally opened
NC Normally closed

_ Aluminium
ac Steel

Dimensions and hydraulic circuit

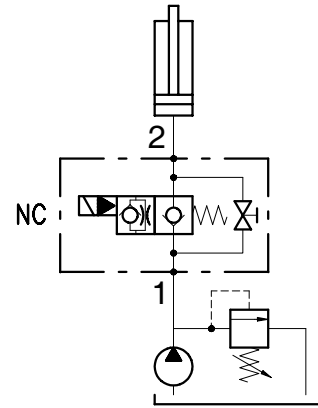
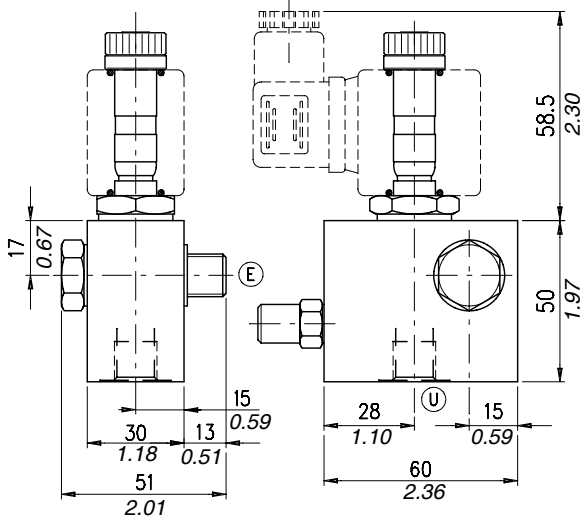

VE/B/RO	E-U
14	G 1/4
38/VP	G 3/8

Rating diagrams

Typical pressure drop vs. flow characteristics

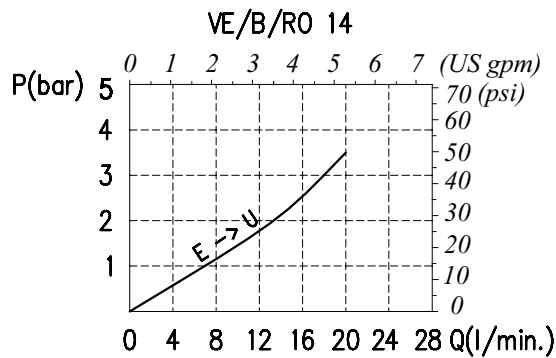

Typical pressure drop vs. flow characteristics

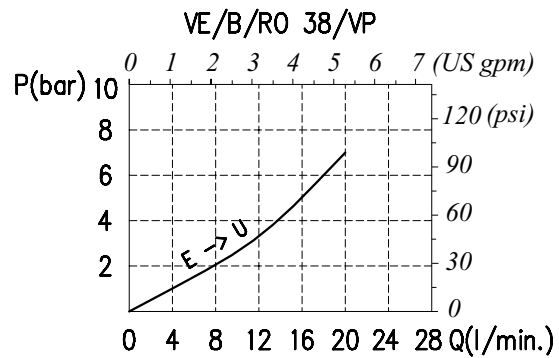

Order code

VE / B / RO □ / □ / □ / □

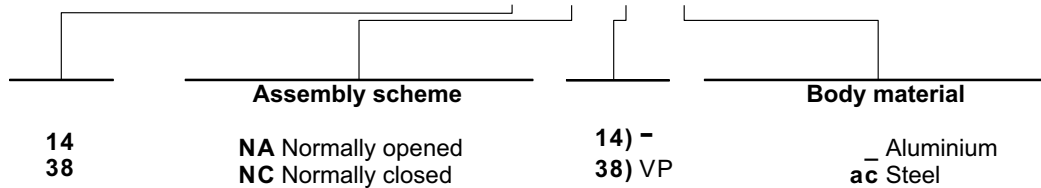



Operation

With the NA (normally opened) valve version and dropped out solenoid, the oil flow is free from E to U and vice versa. When the solenoid is energized the flow is stopped in both directions.

With the NC (normally closed) valve version and dropped out solenoid, the oil flow is stopped in both directions. When the solenoid is energized the flow is free both from E to U and vice versa.

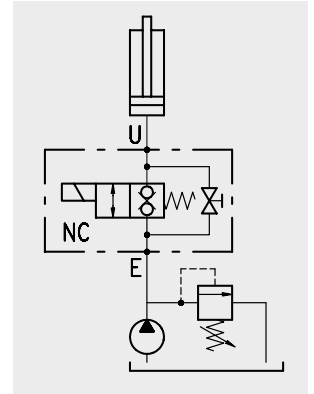

Performance

Body valves

Type	Maximum flow		Maximum pressure		Solenoids	*Oil leaks from E to U	Weight		Cartridge used
	l/min	US gpm	bar	psi			kg	lb	
VE/B 14/ TCW/VG	10	2.6	210 aluminium and steel body	3050 aluminium and steel body	BT see page155	0.10 cm ³ /min. - 61x10 ⁻⁴ in ³ /min. (2 drops) at 210 bar - 3050 psi	0,35	0.77	EW08A see page 36
							aluminium		
							0,77	1.70	
							steel		

*With oil viscosity of 46 cst

Dimensions and hydraulic circuit

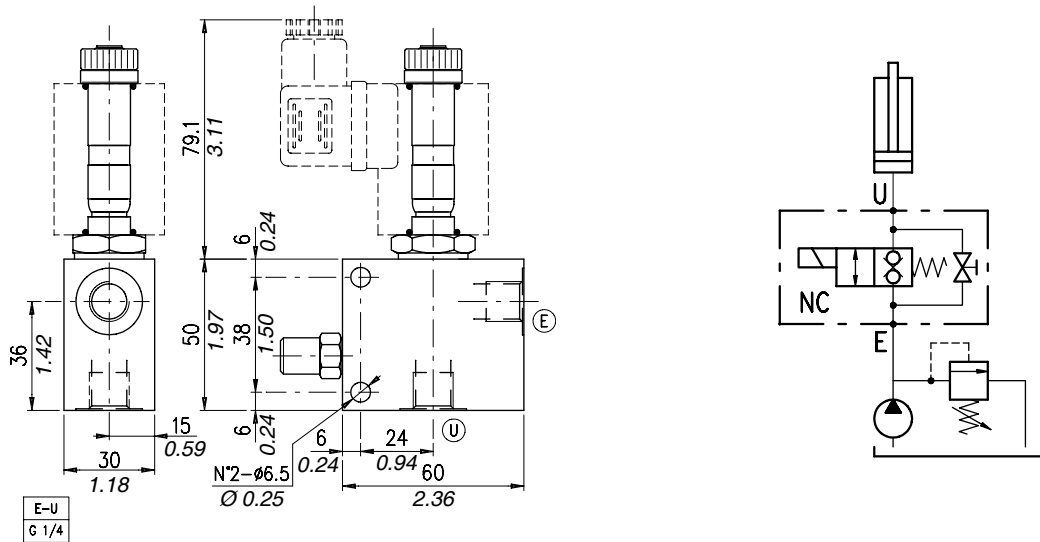

Rating diagrams

Typical pressure drop vs. flow characteristics

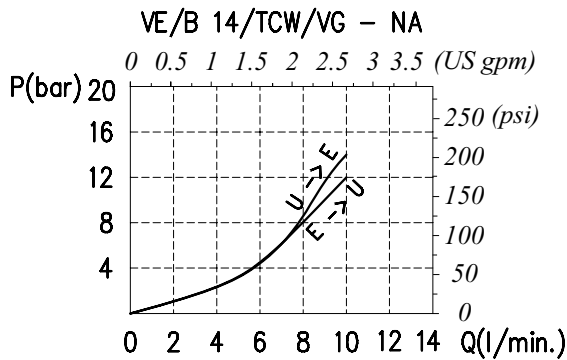

Typical pressure drop vs. flow characteristics

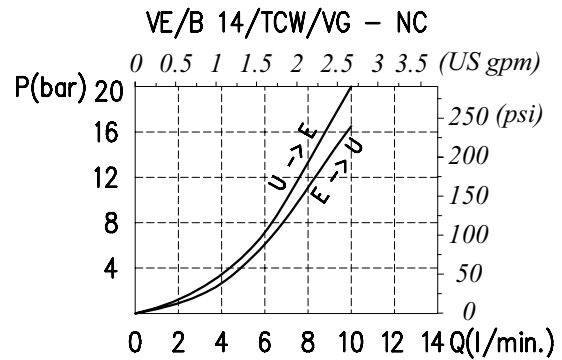

Order code

VE / B / 14 / □ / TCW / VG / □

Assembly scheme

Body material

NA Normally opened
NC Normally closed

_ Aluminium
ac Steel

Operation

With the NA (normally opened) valve version and deenergized solenoid, the oil flow is free from 1 to 2 and vice versa. When the solenoid is energized the flow is stopped from 2 to 1 and is free from 1 to 2.

With the NC (normally closed) valve version and deenergized solenoid, the oil flow is stopped from 2 to 1 and is free from 1 to 2. When the solenoid is energized the flow is free from 1 to 2 and vice versa.

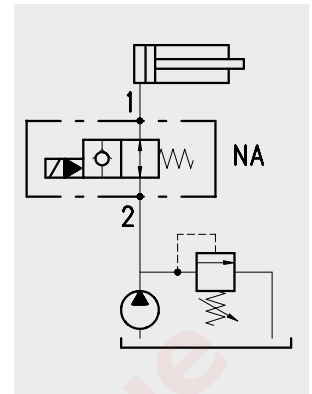

Performance

Cartridges

Type	Maximum flow		Maximum pressure		Solenoids	*Oil leaks from E to U	Weight		Cavities and tools
	l/min	US gpm	bar	psi			kg	lb	
EC10A	50	13	350	5100	BT see page 155	0.10 cm ³ /min. - 61x10 ⁻⁴ in ³ /min. (2 drops) at 210 bar - 3050 psi	0,24	0.53	See cavity SAE 10-2 page 171
EC12A	70	18	350	5100		0,30	0.66	See cavity SAE 12-2 page 171	
EC16A	150	40	350	5100		0,30	0.66	See cavity SAE 16-2 page 171	

*with oil viscosity of 46 cst

Dimensions and hydraulic circuit

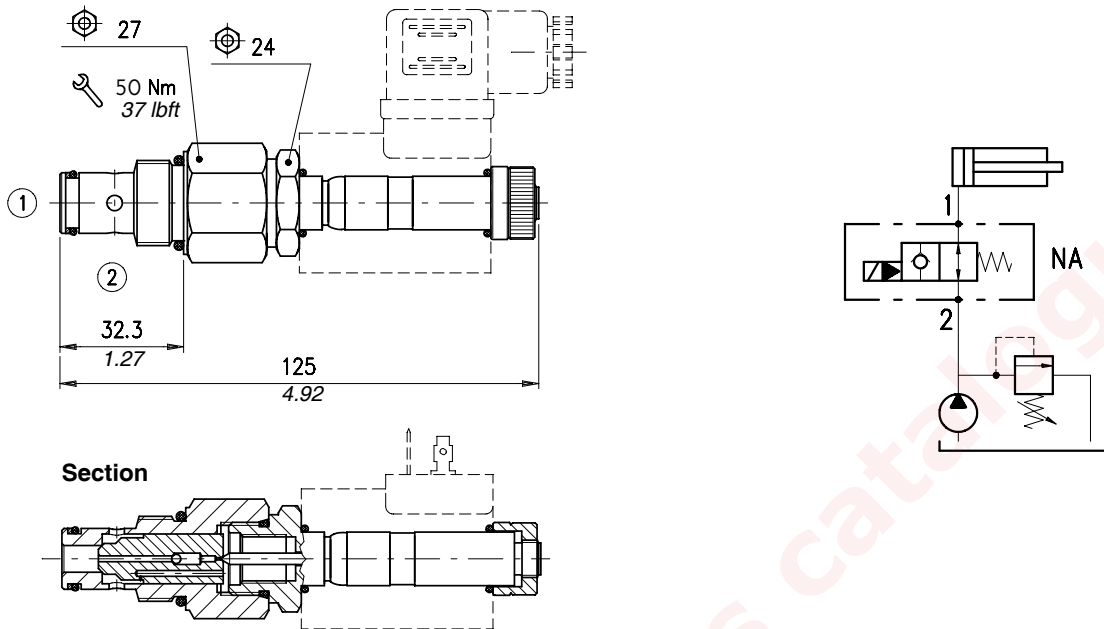

Rating diagrams

Typical pressure drop vs. flow characteristics

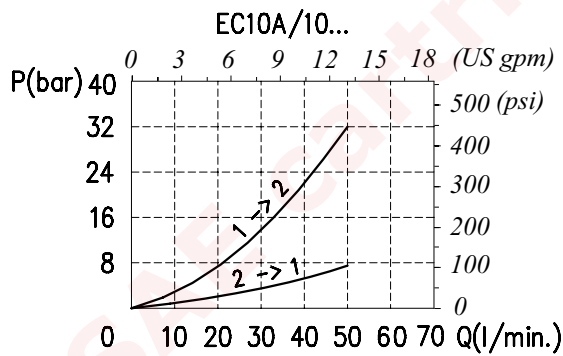

Typical pressure drop vs. flow characteristics

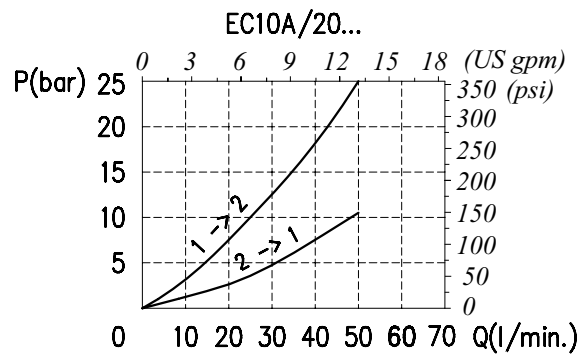

Order code

EC 10A / □ -0 -□ -□

Assembly scheme

- 1) NA Normally opened
- 2) NC Normally closed

Manual override option
(see page 163)

- N) No emergency
- P) Button (only for NA)
- T) Screw

Seals

- B) Buna
- V) Viton

Dimensions and hydraulic circuit

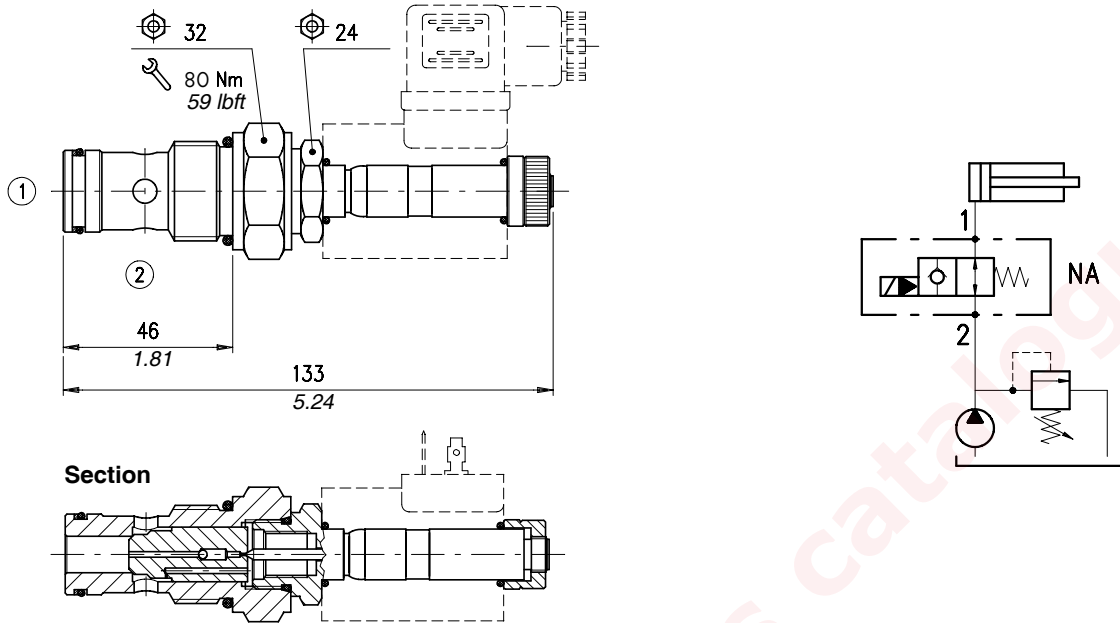

Rating diagrams

Typical pressure drop vs. flow characteristics

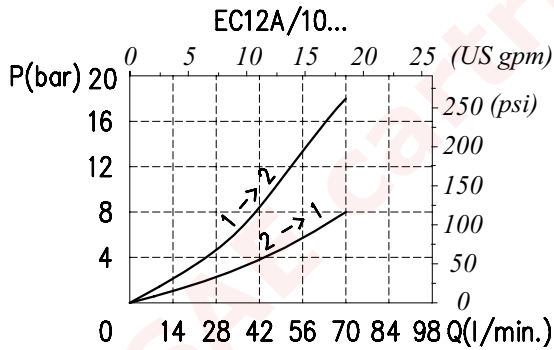

Typical pressure drop vs. flow characteristics

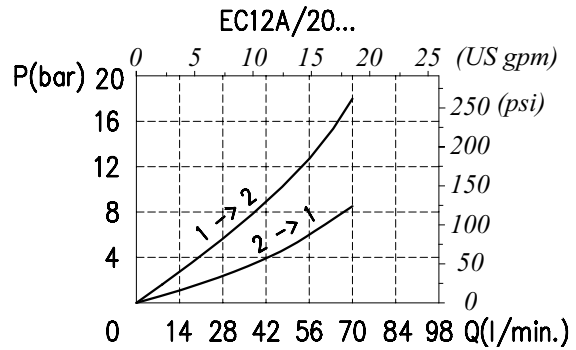

Order code

EC 12A / □ -0 -□ -□

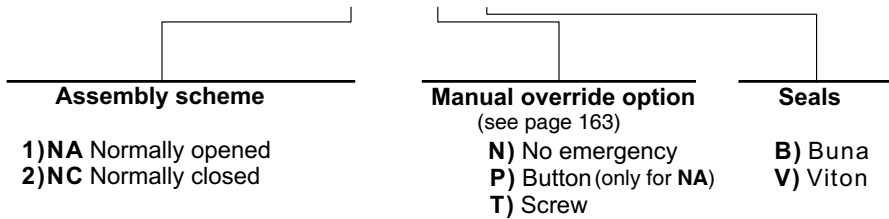

Dimensions and hydraulic circuit

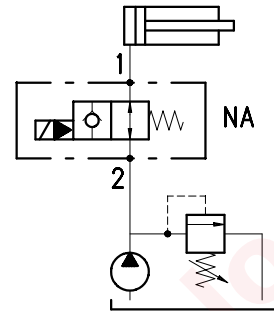
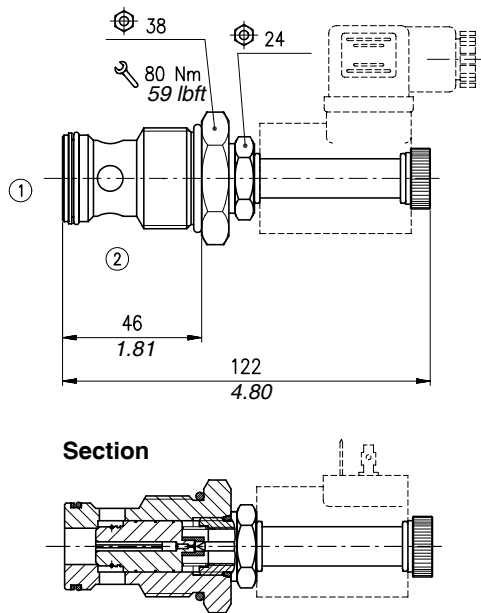

Rating diagrams

Typical pressure drop vs. flow characteristics

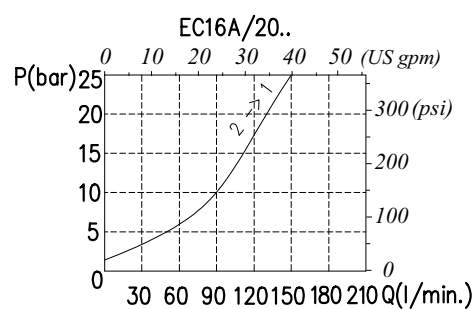
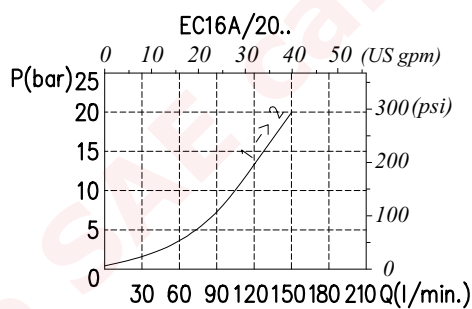
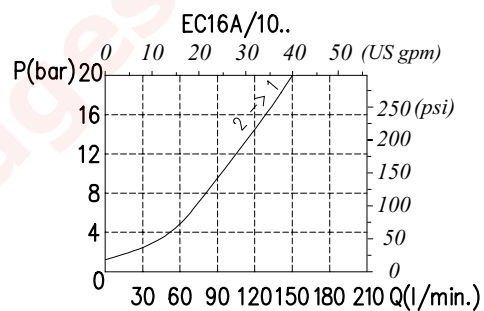
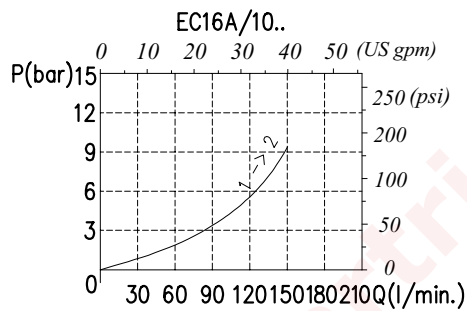

Order code

EC 16A / □ - 0 - □ - □

Assembly scheme

- 1) NA Normally opened
- 2) NC Normally closed

Manual override option
(see page 163)

- N) No emergency
- P) Button (only for NA)
- T) Screw

Seals

- B) Buna
- V) Viton

Operation

2 Way electric valves, direct acting, spool type.

With the NA (normally opened) valve version and deenergized solenoid, the oil flow is free from 1 to 2 and vice versa. When the solenoid is energized the flow is stopped in both directions.

With the NC (normally closed) valve version and deenergized solenoid, the oil flow is stopped from 1 to 2 and vice versa. When the solenoid is energized the flow is free in both directions.

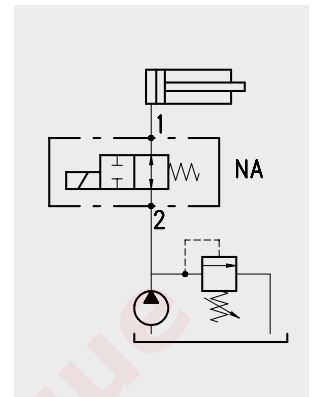

Performance

Cartridges

Type	Maximum flow		Maximum pressure		Solenoids	*Oil leaks from 1 to 2	Weight		Cavities and tools
	l/min	US gpm	bar	psi			kg	lb	
EE08A	8	2.1	210	3050	BE-EC36 see page 157	30 cm ³ /min. - 1.83 in ³ /min. at 210 bar - 3050 psi	0,18	0.40	see cavity SAE 8-2 page 171
EE10A	30	8			BIN 19 see page 158	55 cm ³ /min. - 3.36 in ³ /min. at 210 bar - 3050 psi	0,28	0.62	see cavity SAE 10-2 page 171
EE12A	40	10.5			BIN 22 see page 159	75 cm ³ /min. - 4.58 in ³ /min. at 210 bar - 3050 psi	0,44	0.12	see cavity SAE 12-2 page 171

*With oil viscosity of 46 cst

Dimensions and hydraulic circuit

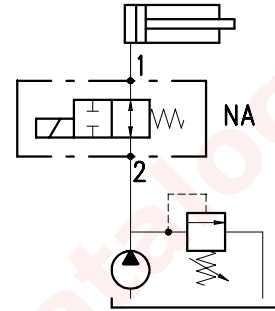
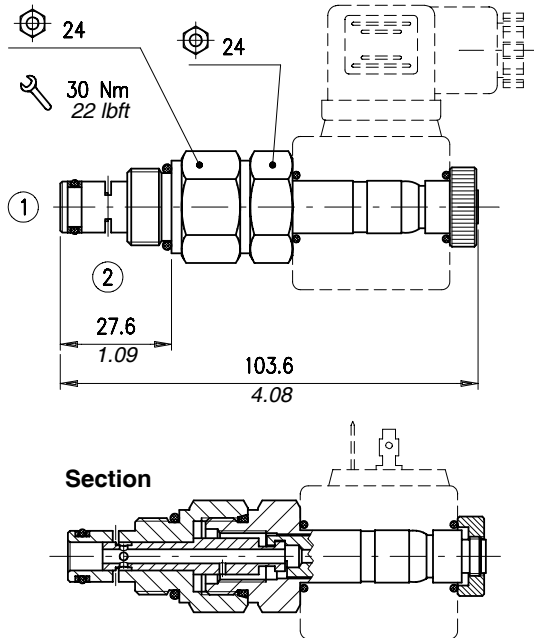

Rating diagrams

Typical pressure drop vs. flow characteristics

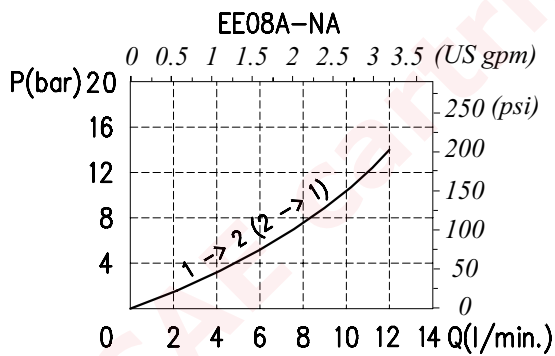

Typical pressure drop vs. flow characteristics

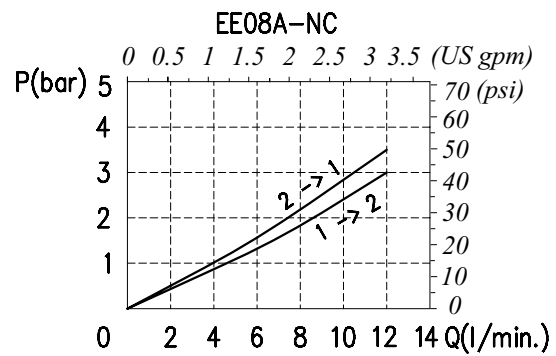

Order code

EE 08A / □ -0 -□ -□

Assembly scheme

- 1) NA Normally opened
- 2) NC Normally closed

Manual override option
(see page 163)

- N) No emergency
- P) Button
- T) Screw

Seals

- B) Buna
- V) Viton

Dimensions and hydraulic circuit

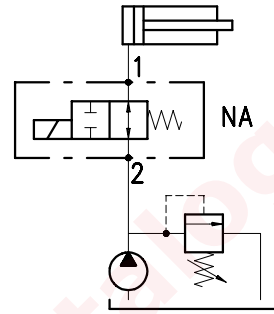
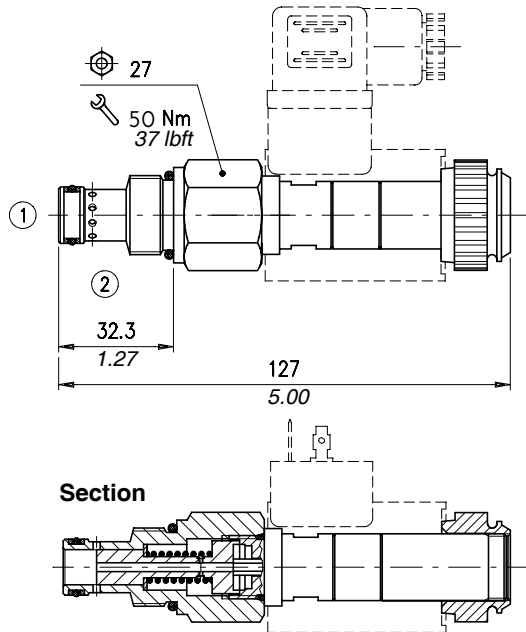

Rating diagrams

Typical pressure drop vs. flow characteristics

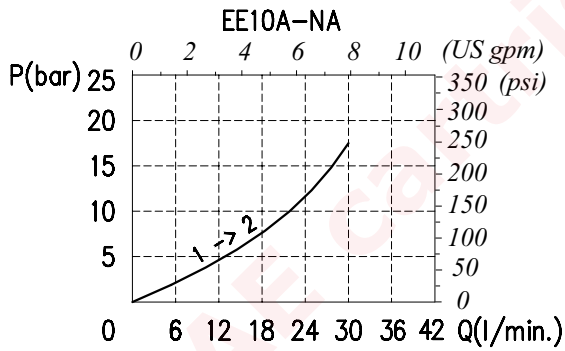

Typical pressure drop vs. flow characteristics

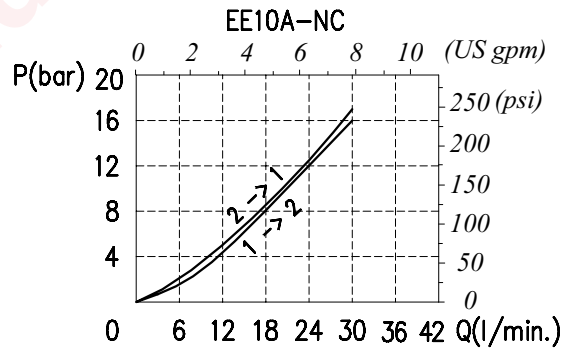

Order code

EE 10A / □ -0 -□ -□

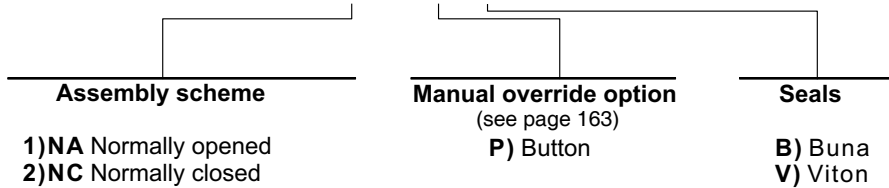

Dimensions and hydraulic circuit

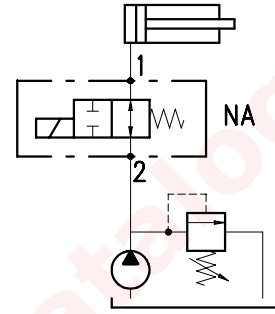
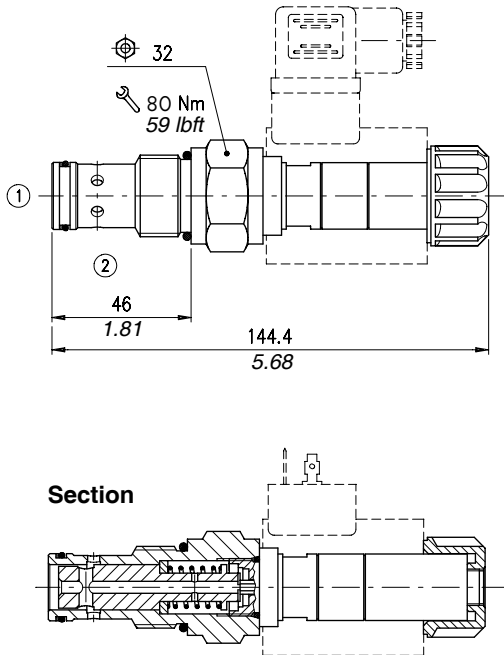

Rating diagrams

Typical pressure drop vs. flow characteristics

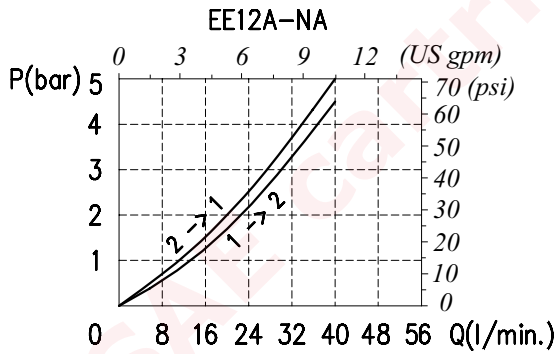

Typical pressure drop vs. flow characteristics

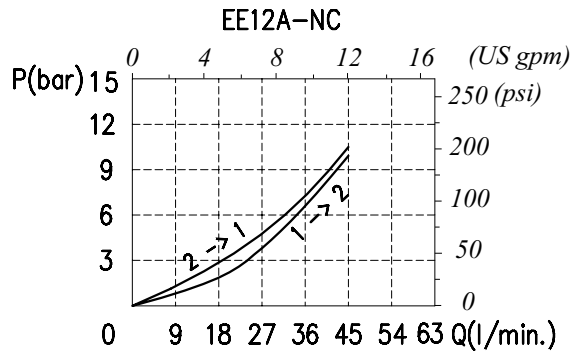

Order code

EE 12A / □ -0 -□ -□

Assembly scheme

- 1) NA Normally opened
- 2) NC Normally closed

Manual override option

(see page 163)

P) Button

Seals

- B) Buna
- V) Viton

Operation

With the NA (normally opened) valve version and deenergized solenoid, the oil flow is free from 2 to 1 and vice versa. When the solenoid is energized the flow is stopped in both directions.

With the NC (normally closed) valve version and deenergized solenoid, the oil flow is stopped in both directions. When the solenoid is energized the flow is free from 2 to 1 and vice versa.

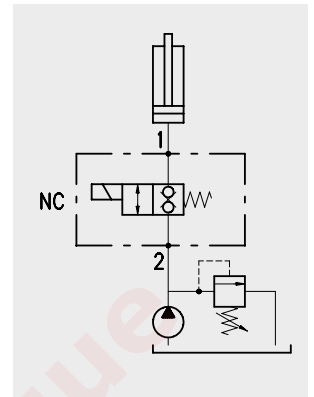

Performance

Cartridges

Type	Maximum flow		Maximum pressure		Solenoids	*Oil leaks from 1 to 2	Weight		Cavities and tools
	l/min	US gpm	bar	psi			kg	lb	
EW08A	10	2.6	210	3050	BT see page 155	0.10 cm ³ /min. - 61x10 ⁻⁴ in ³ /min. (2 drops) at 210 bar -3050 psi	0,16	0.35	See cavity SAE 8-2 page 171
EW10A/20	25	6.6			BIN 19 see page 158	0.25 cm ³ /min. - 15x10 ⁻³ in ³ /min. (2 drops) at 210 bar -3050 psi	0,25	0.77	See cavity SAE 10-2 page 171
EW10B/10	30	8			BIN 22 see page 159	0.25 cm ³ /min. - 15x10 ⁻³ in ³ /min. (5 drops) at 210 bar -3050 psi	0,25	0.77	
EW12B/10	50	13					0,54	0.97	See cavity SAE 12-2 page 171
EW12C/20									

*with oil viscosity of 46 cst

Dimensions and hydraulic circuit

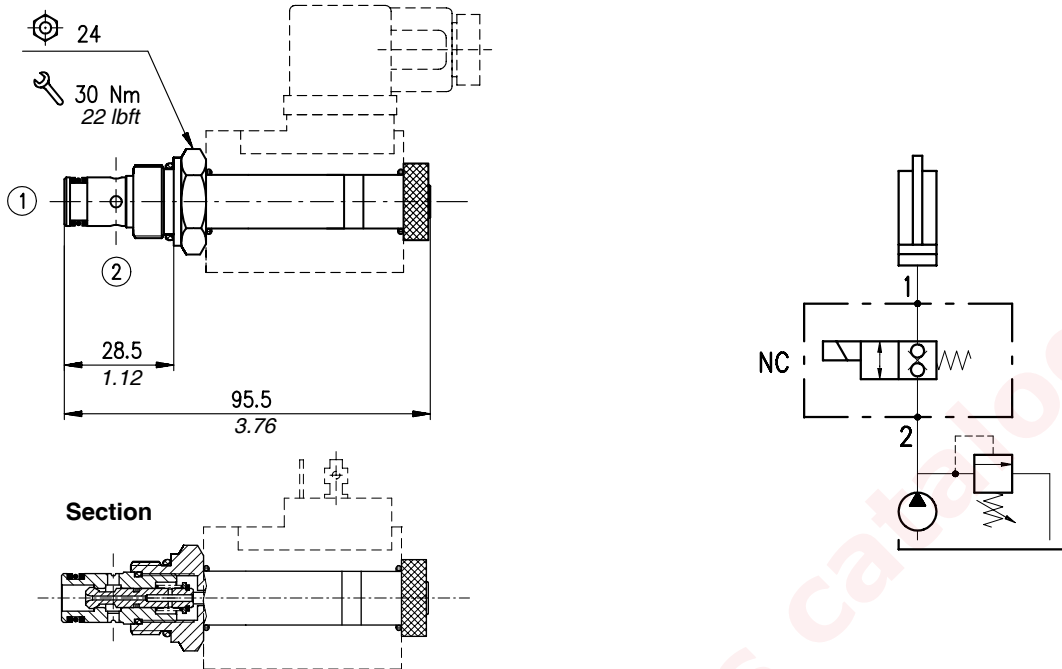

Rating diagrams

Typical pressure drop vs. flow characteristics

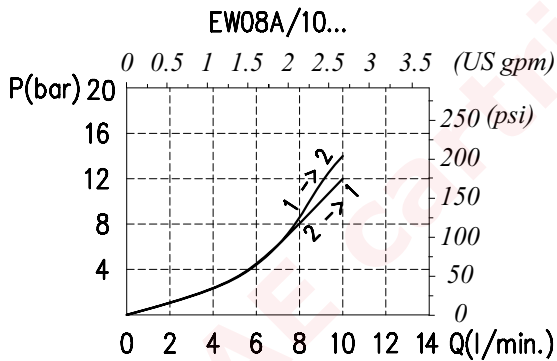

Typical pressure drop vs. flow characteristics

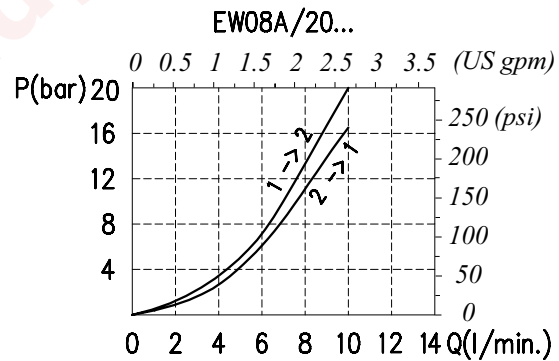

Order code

EW 08A / □ -0 -□ -□

Assembly scheme

- 1) NA Normally opened
- 2) NC Normally closed

Manual override option
(see page 163)

- N) No emergency
- P) Button (only NC)
- T) Screw

Seals

- B) Buna
- V) Viton

Dimensions and hydraulic circuit

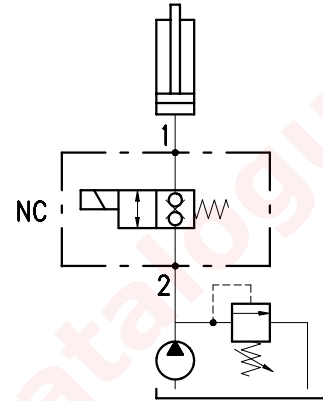
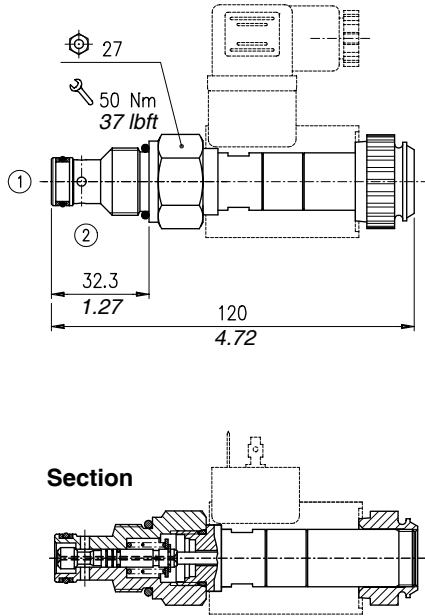

Rating diagrams

Typical pressure drop vs. flow characteristics

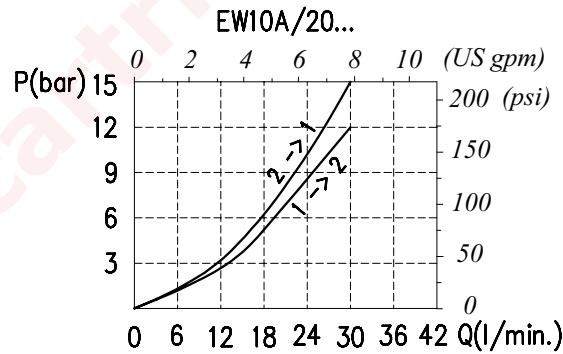

Order code

EW 10A / 2 -0 -□ -□

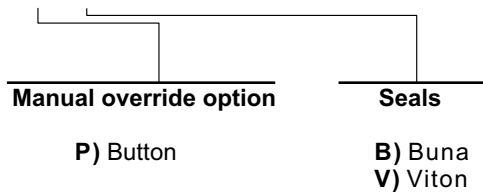

Dimensions and hydraulic circuit

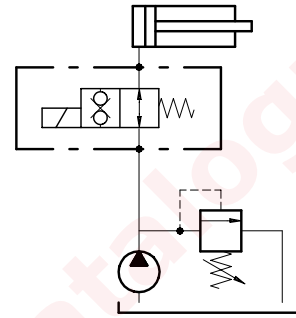
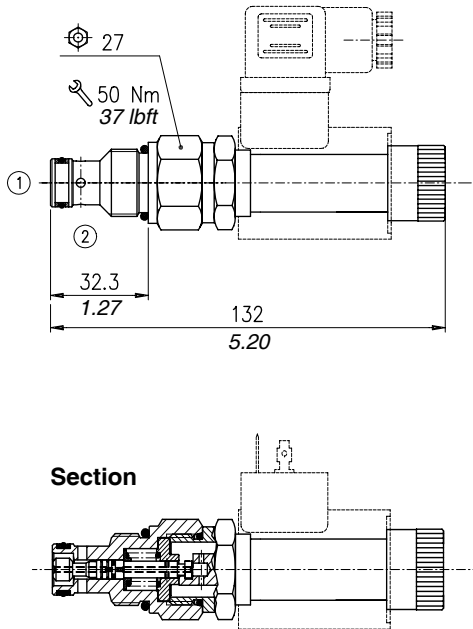

Rating diagrams

Typical pressure drop vs. flow characteristics

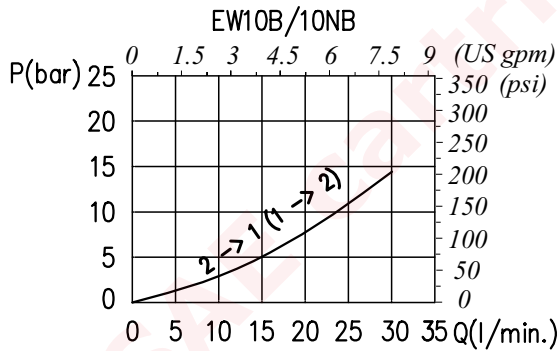

Operation range

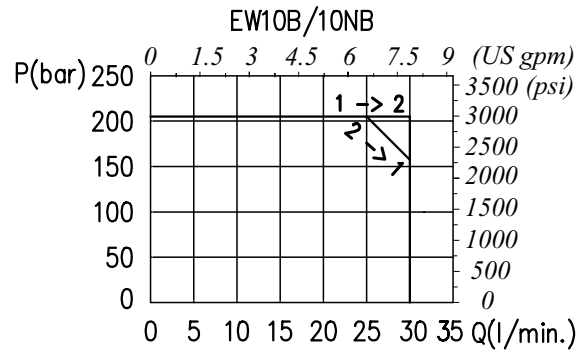

Order code

EW 10B /1-0 -N - □

Manual override option
(see page 163)
N) No emergency

Seals
B) Buna
V) Viton

Dimensions and hydraulic circuit

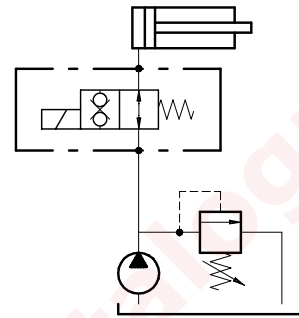
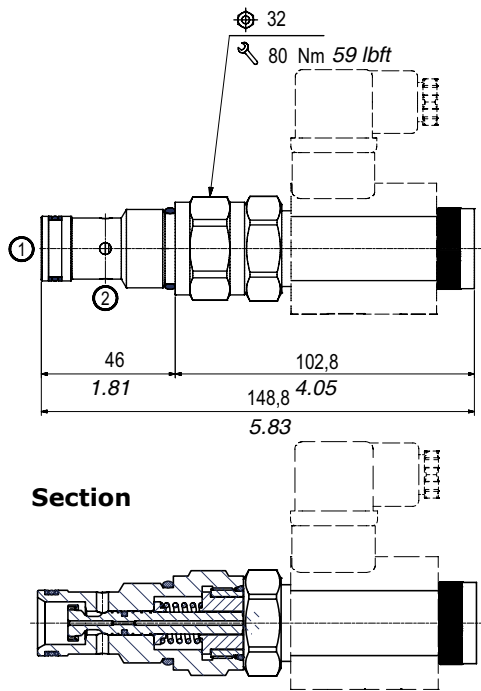

Rating diagrams

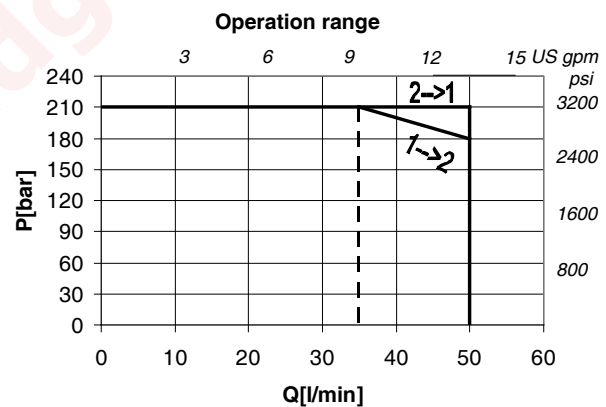
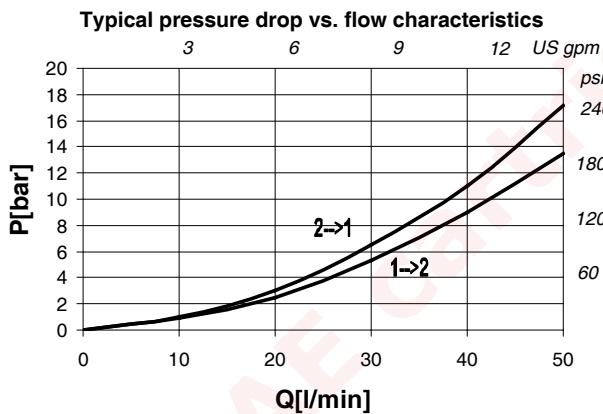

Order code

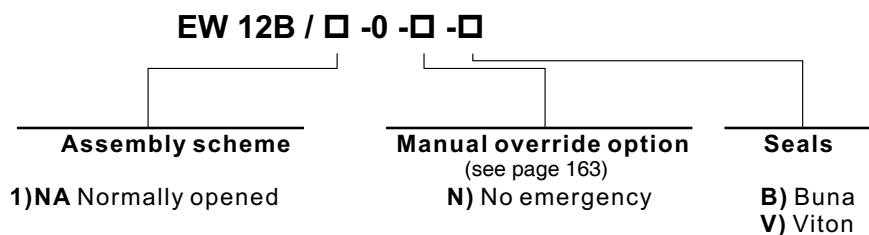

Dimensions and hydraulic circuit

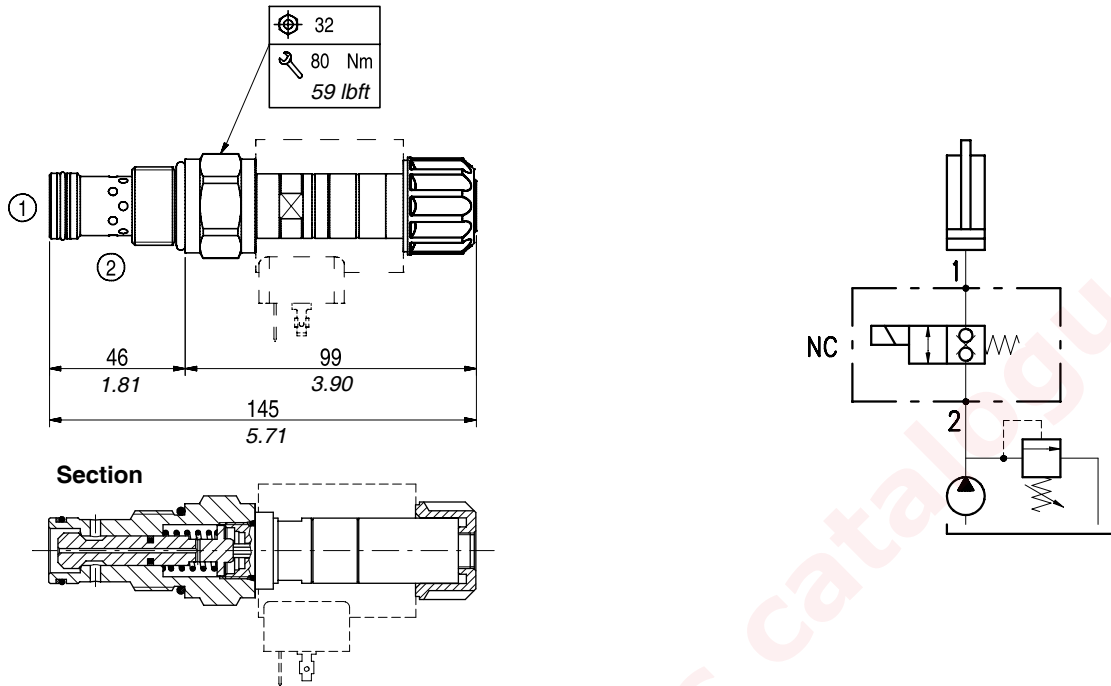

Rating diagrams

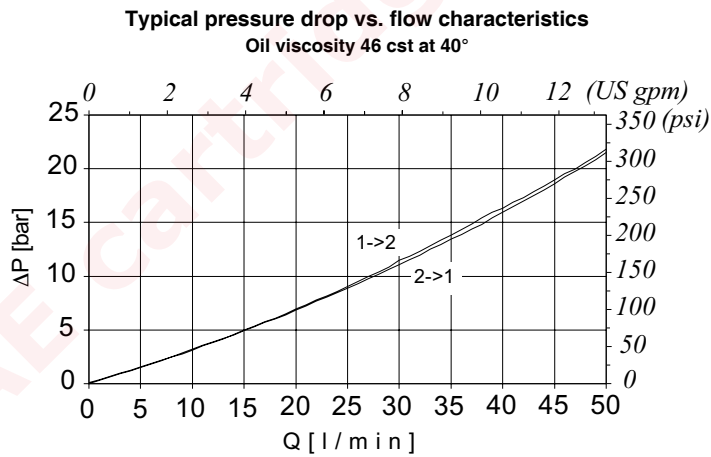

Order code

EW 12C / □ -0 -□ -□

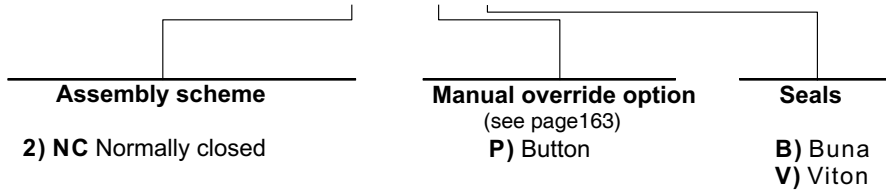

Operation

When the solenoid is deenergized the valve allows free oil flow from 3 to 2 and vice versa, while the way in 1 is sealed.

When the solenoid is energized the valve allows free oil flow from 2 to 1 and vice versa, while the way in 3 is sealed.

The way in 1 may not be used as discharge.

EJ08B/1 NOTE: in case of pressure in 1 greater than 100 bar -1450 psi ask our technical office for advise.

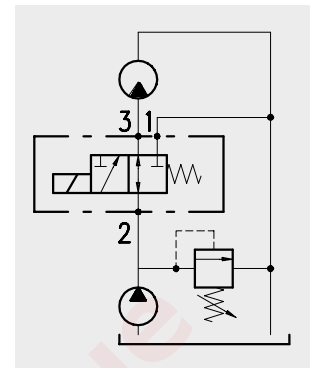

Performance

Cartridges

Type	Maximum flow		Maximum pressure		Solenoids	*Oil leaks from 1 to 2	Weight		Cavities and tools
	l/min	US gpm	bar	psi			kg	lb	
EJ08A/1	10	2.6	210	3050	BE/EC36 see page 157	10 cm ³ /min. - 0.61 in ³ /min. at 210 bar - 3050 psi	0,175	0.38	See cavity SAE 8-3 page 172
EJ10A/1	30	8			BIN 19 see page 158	50 cm ³ /min. - 3.05 in ³ /min. at 210 bar - 3050 psi	0,275	0.61	See cavity SAE 10-3 page 172
EJ12A/1	40	10.5			BIN 22 see page 159	60 cm ³ /min. - 3.66 in ³ /min. at 210 bar - 3050 psi	0,500	1.10	See cavity SAE 12-3 page 172
EJ08B/1	12	3.1			BT vedi pag.155	14 cm ³ /min. - 0.85 in ³ /min. at 210 bar -3050 psi	0,185	0.41	See cavity SAE 8-3 page 172
EJ08M/1	23**	6*	250**	3600*	BE/EC36 see page 157	40 cm ³ /min. - 2.44 in ³ /min. at 250 bar -3600 psi	0,125	0.27	

*With oil viscosity of 46 cst

**see the performance limit diagram

Dimensions and hydraulic circuit

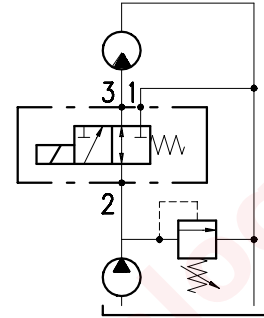
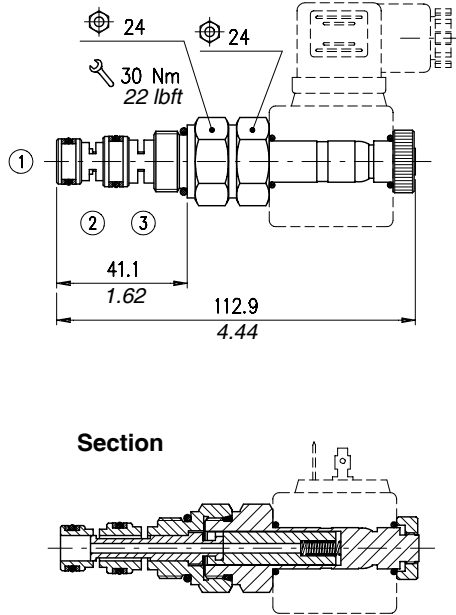

Rating diagrams

Typical pressure drop vs. flow characteristics

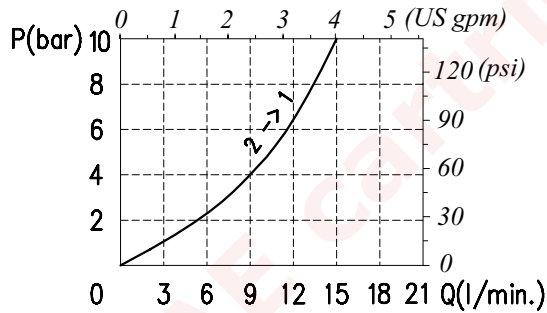

Typical pressure drop vs. flow characteristics

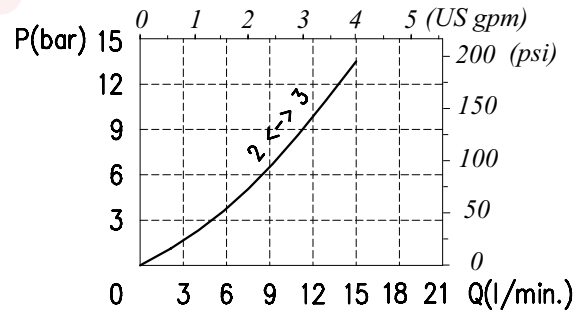

Order code

EJ 08A / 10 □ - □

Manual override option

(see page 163)

N) No emergency (standard)
T) Screw

Seals

B) Buna
V) Viton

Dimensions and hydraulic circuit

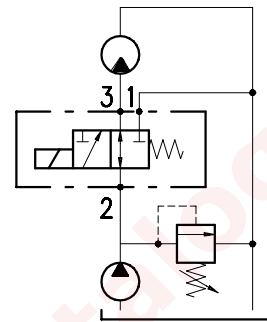
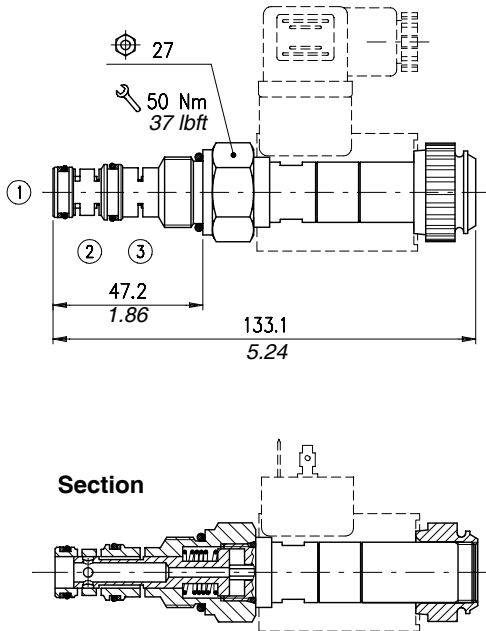

Rating diagrams

Typical pressure drop vs. flow characteristics

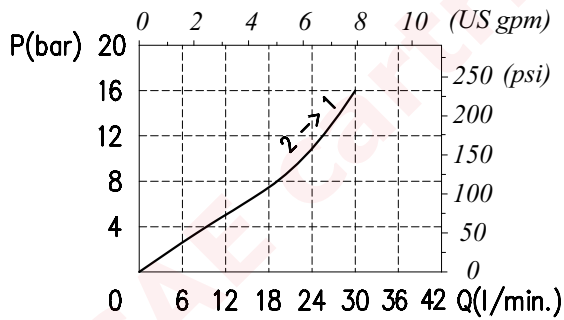

Typical pressure drop vs. flow characteristics

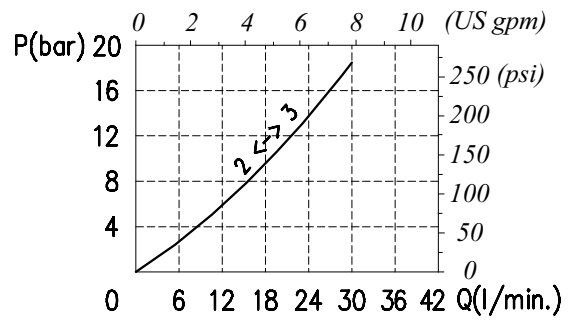

Order code

EJ 10A / 10 P □

Seals

- B)** Buna
- V)** Viton

Dimensions and hydraulic circuit

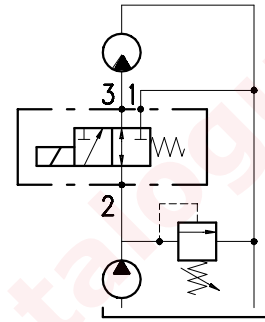
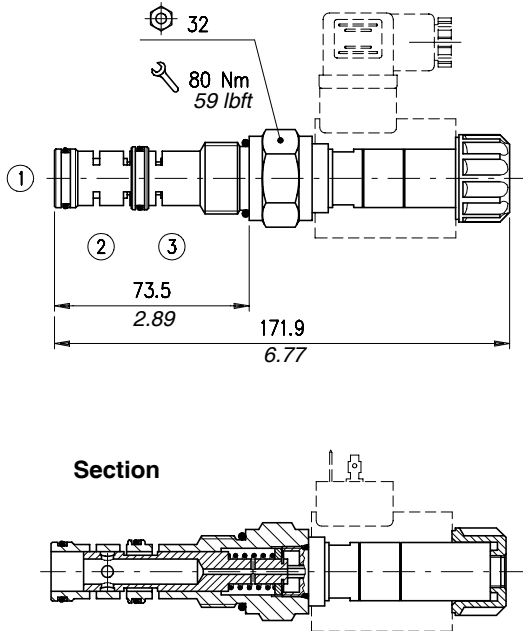

Rating diagrams

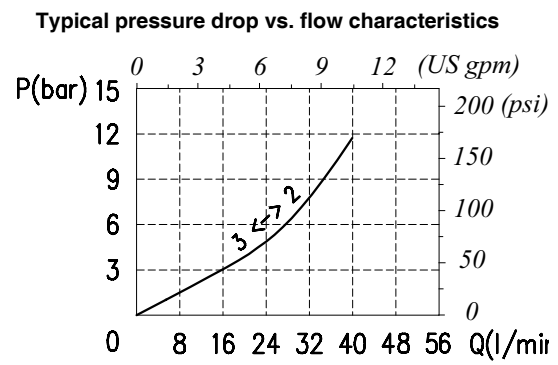
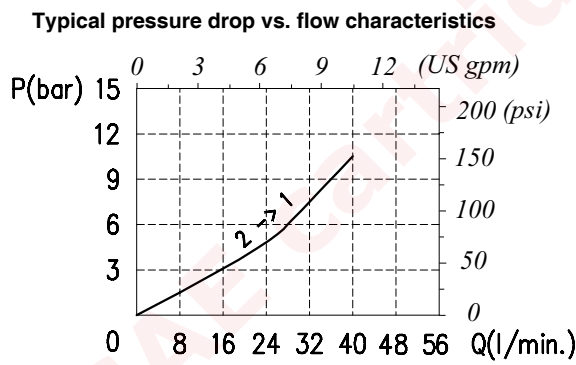

Order code

EJ 12A / 10 P □

Seals

B) Buna
V) Viton

Dimensions and hydraulic circuit

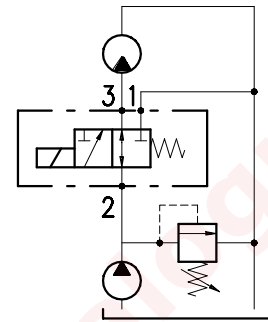
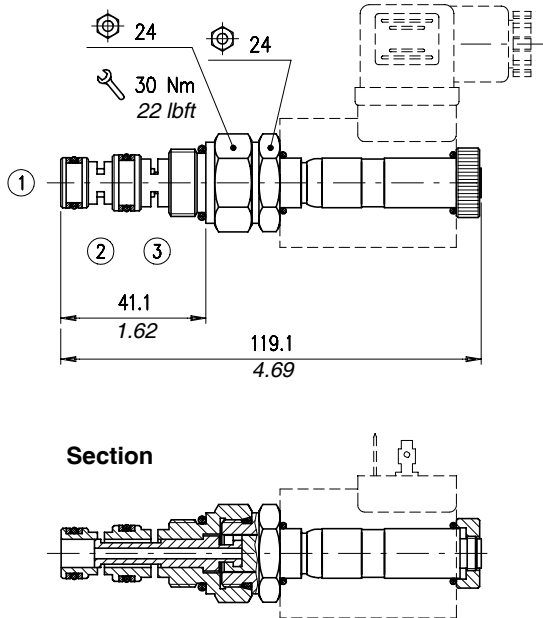

Rating diagrams

Typical pressure drop vs. flow characteristics

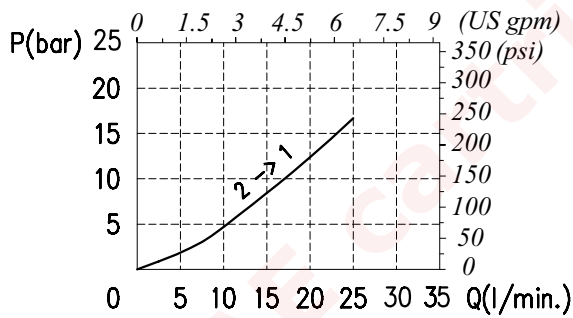

Typical pressure drop vs. flow characteristics

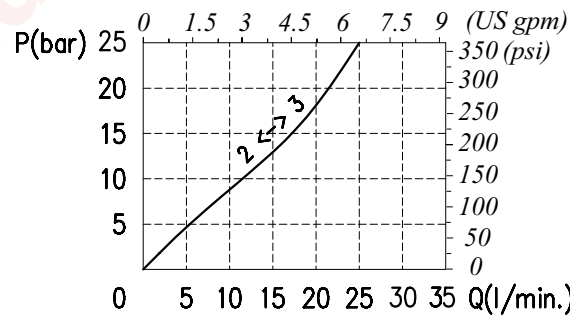

Order code

EJ 08B / 10 □ - □

Manual override option

(see page 163)

- N)** No emergency (standard)
- T)** Screw

Seals

- B)** Buna
- V)** Viton

Dimensions and hydraulic circuit

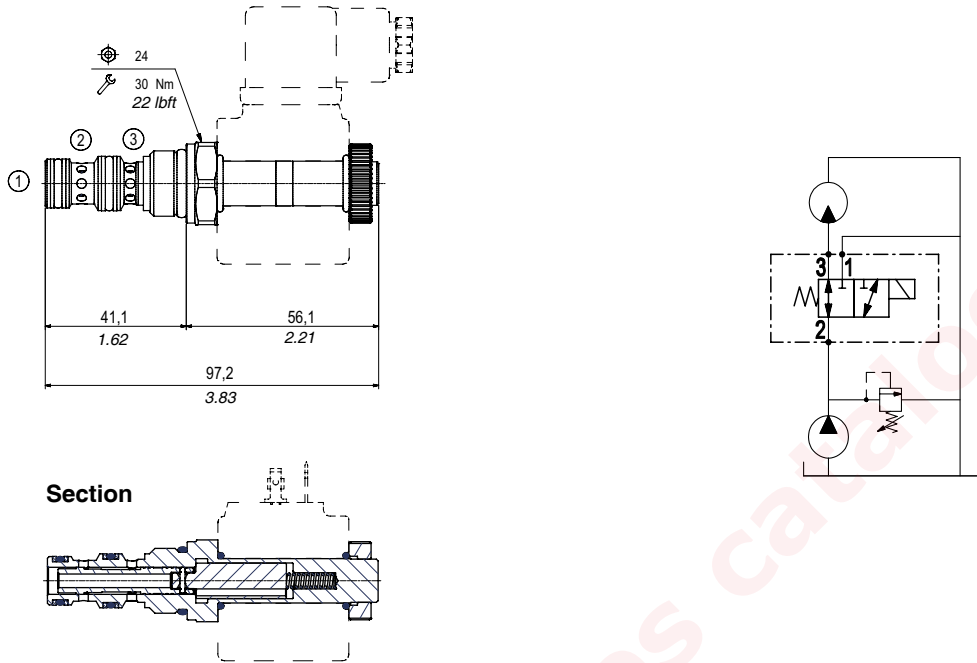

Rating diagrams

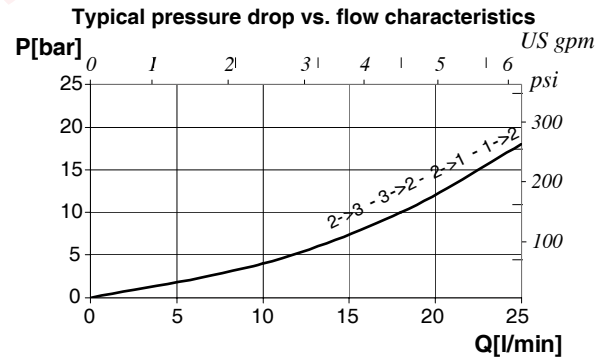
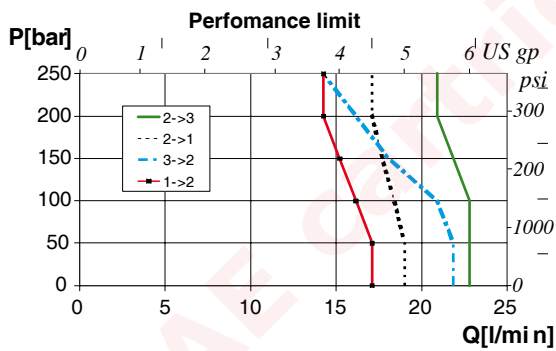

Order code

EJ08M/10 -

Manual override option
(see page 163)

- N)** No emergency (standard)
- F)** Pull button
- T)** With screw
- Q)** Pull button with safety lock

Seals

- B)** Buna
- V)** Viton

Operation

When the solenoid is deenergized the valve allows free oil flow from 3 to 1 and vice versa, while the way in 2 is sealed.

When the solenoid is energized the valve allows free oil flow from 2 to 1 and vice versa, while the way in 3 is sealed.

The way in 1 may not be used as discharge.

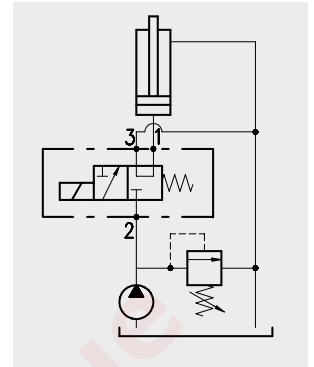

Performance

Cartridges

Type	Maximum flow		Maximum pressure		Solenoids	*Oil leaks from 1 to 2	Weight		Cavities and tools
	l/min	US gpm	bar	psi			kg	lb	
EJ08A/2	7	1.8	210	3050	BE/EC36 see page 157	10 cm ³ /min. - 0.61 in ³ /min. at 210 bar - 3050 psi	0,175	0.38	see cavity SAE 8-3 page 172
EJ10A/2	30	8			BIN 19 see page 158	100 cm ³ /min. - 0.61 in ³ /min. at 210 bar - 3050 psi	0,275	0.61	see cavity SAE 10-3 page 172
EJ12A/2	40	10.5			BIN 22 see page 159	60 cm ³ /min. - 3.66 in ³ /min. at 210 bar - 3050 psi	0,500	1.10	see cavity SAE 12-3 page 172
EJ08B/2	12	3.2			BT see page 155	14 cm ³ /min. - 0.85 in ³ /min. at 210 bar - 3050 psi	0,185	0.41	see cavity SAE 8-3 page 172
EJ10B/2	20	5.3			BC 16 see page 160	30 cm ³ /min. - 1.83 in ³ /min. at 210 bar - 3050 psi	0,285	0.63	see cavity SAE 10-3 page 172
EJ08M/2	25**	6.6**			250**	3600**	BE/EC36 see page 157	40 cm ³ /min. - 2.44 in ³ /min. at 250 bar - 3600 psi	0,125

*with oil viscosity of 46 cst

**see the performance limit diagram

Dimensions and hydraulic circuit

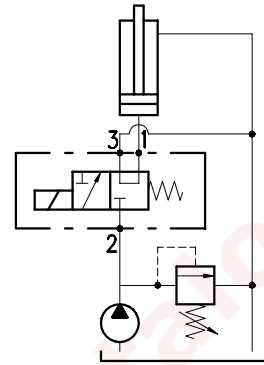
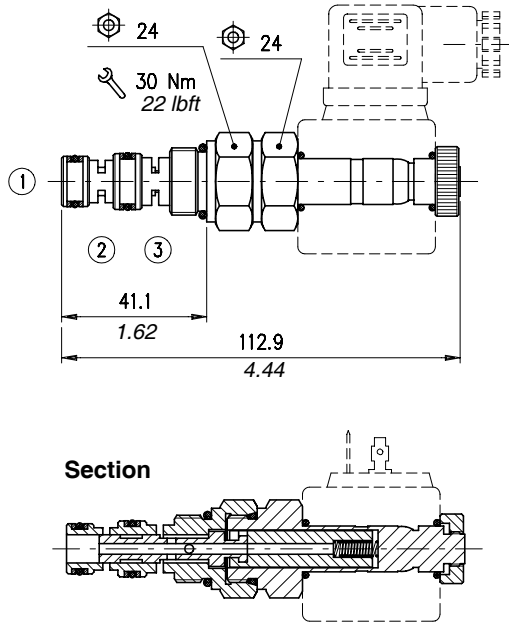

Rating diagrams

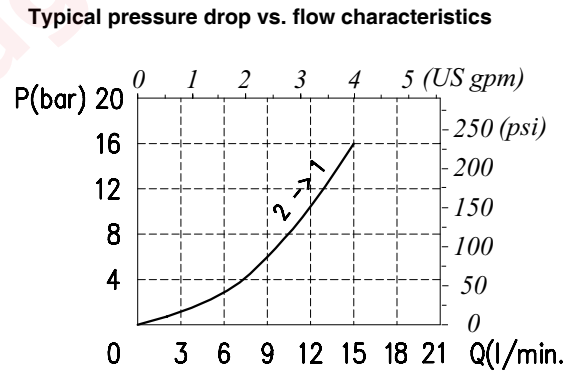
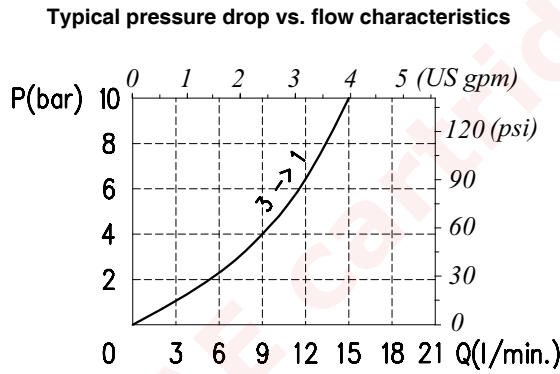

Order code

EJ 08A / 20 N □

Seals

B) Buna
V) Viton

Dimensions and hydraulic circuit

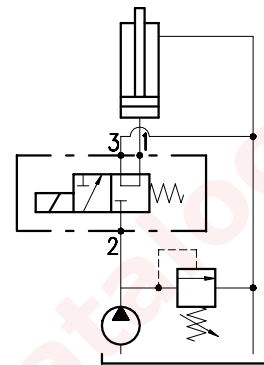
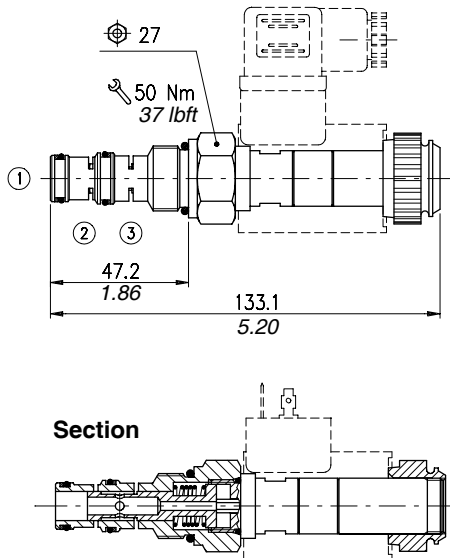

Rating diagrams

Typical pressure drop vs. flow characteristics

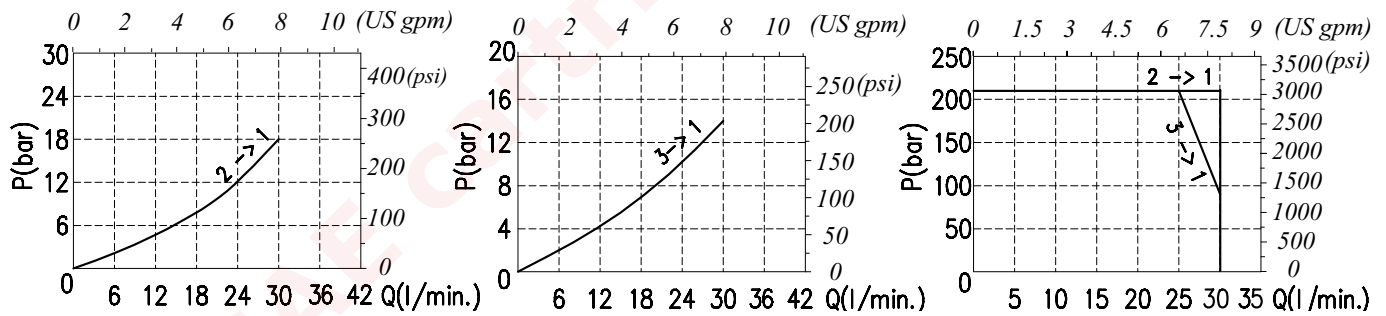

Order code

EJ 10A / 20 P □

Seals

B) Buna
V) Viton

Dimensions and hydraulic circuit

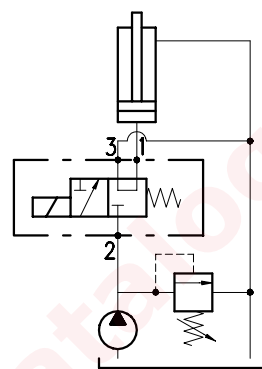
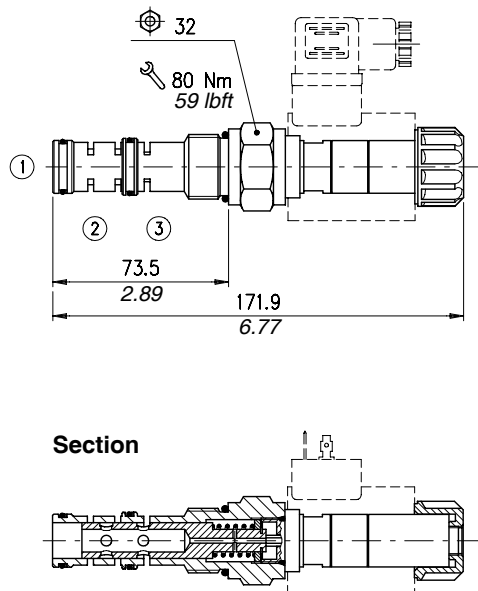

Rating diagrams

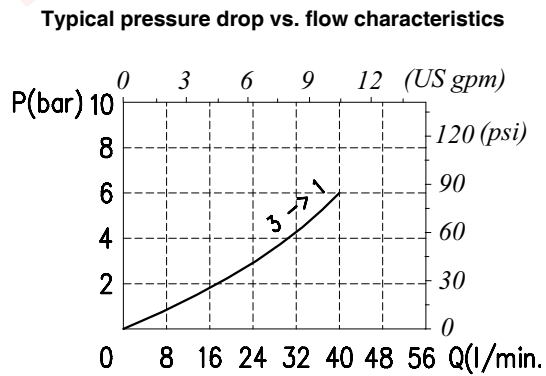
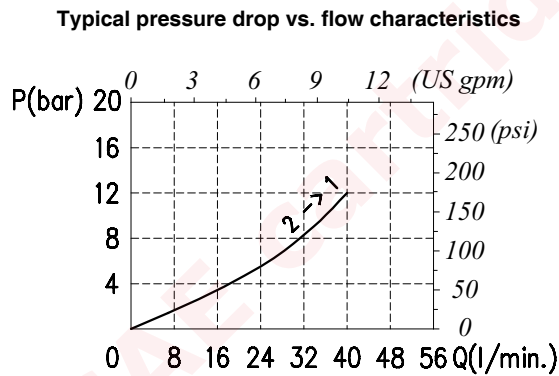

Order code

EJ 12A / 20 P □

Seals

B) Buna
V) Viton

Dimensions and hydraulic circuit

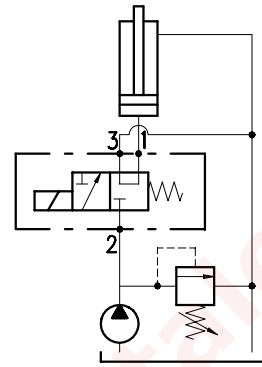
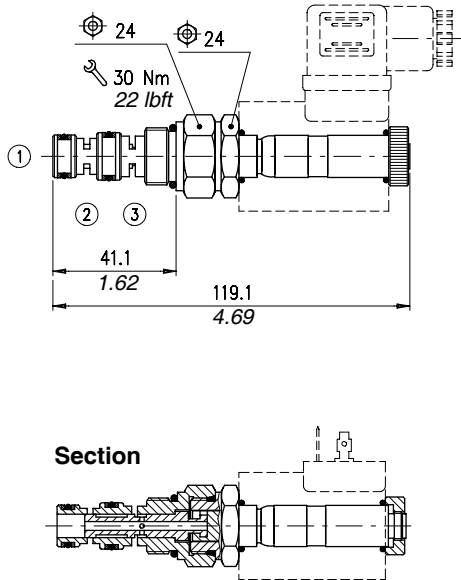

Rating diagrams

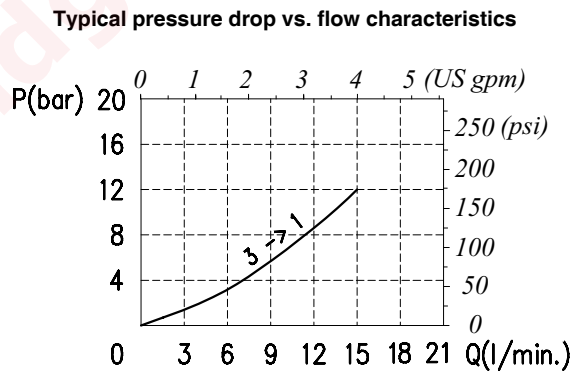
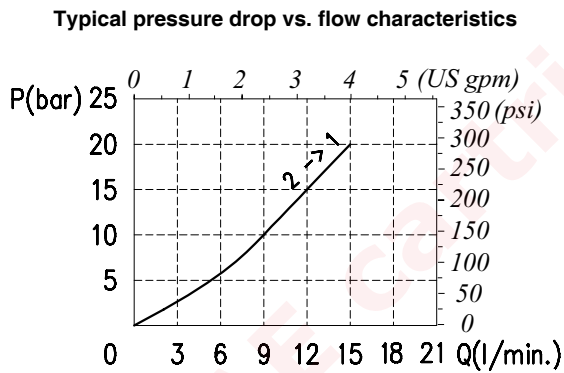

Order code

EJ 08B / 20 □ - □

Manual override option

(see page 163)

N) No emergency (standard)
T) Screw

Seals

B) Buna
V) Viton

Dimensions and hydraulic circuit

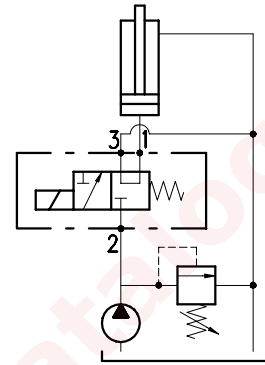
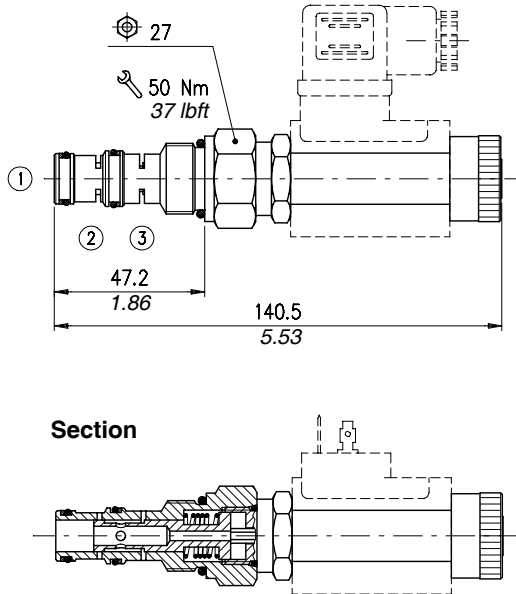

Rating diagrams

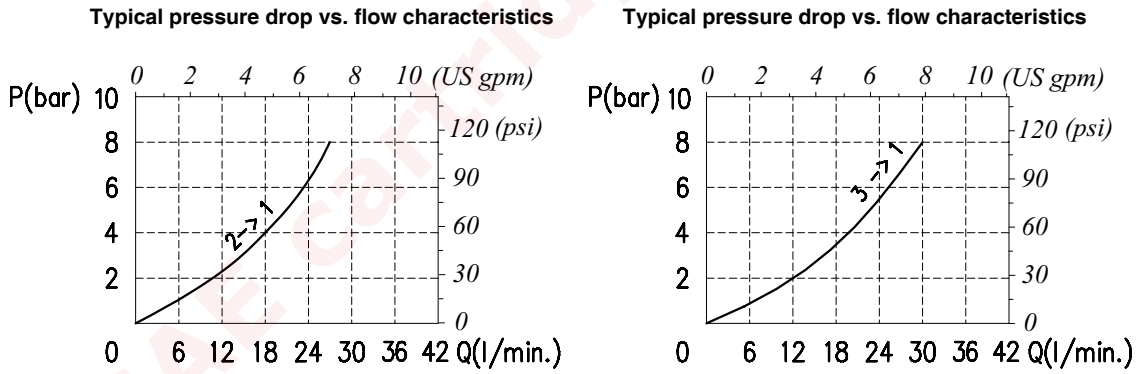

Order code

EJ 10B / 20 N □

Seals

B) Buna
V) Viton

Dimensions and hydraulic circuit

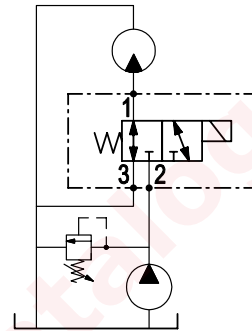
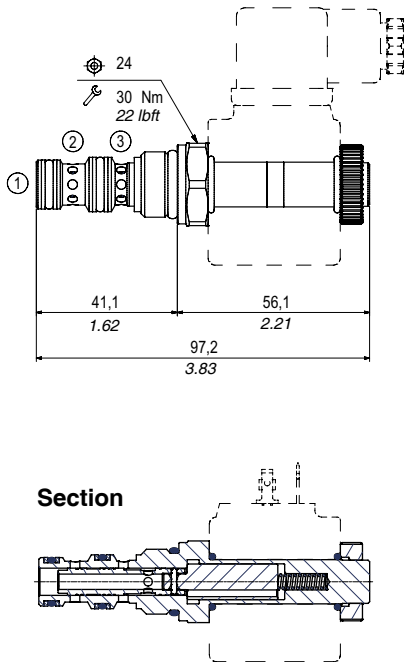

Rating diagrams

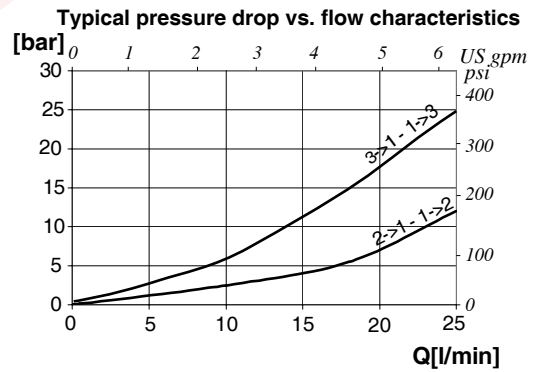
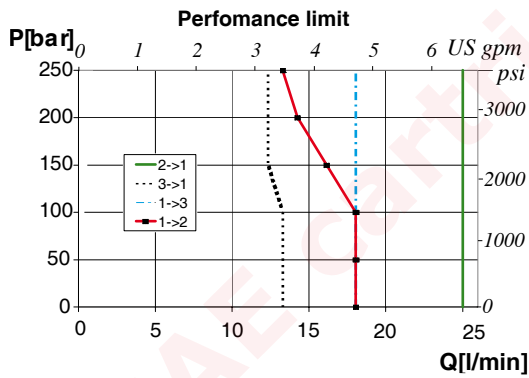

Order code

EJ08M/20 -

Manual override option
(see page 163)

- N)** No emergency (standard)
- F)** Pull button
- T)** With screw
- Q)** Pull button with safety lock

Seals

- B)** Buna
- V)** Viton



Operation

When the solenoid is deenergized the valve allows free oil flow from 3 to 2 and vice versa, while the way in 1 is sealed.

When the solenoid is energized the valve allows free oil flow from 3 to 1 and vice versa, while the way in 2 is sealed. (In case of pressure in 1 greater than 100 bar - 1450 psi ask our technical office for advise).

The way in 1 may not be used as discharge.

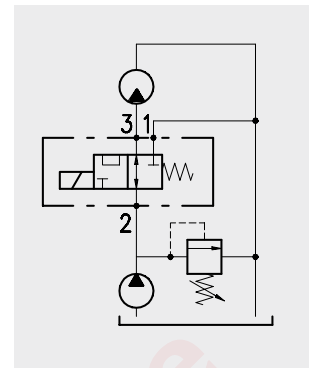

Performance

Cartridges

Type	Maximum flow		Maximum pressure		Solenoids	*Oil leaks from 1 to 2	Weight		Cavities and tools
	l/min	US gpm	bar	psi			kg	lb	
EJ08A/3	10	2.6	210	3050	BE/EC36 see page 157	10 cm ³ /min. - 0.61 in ³ /min at 210 bar - 3050 psi	0,175	0.38	see cavity SAE 8-3 page 172
EJ10A/3	30	8			BIN 19 see page 158	50 cm ³ /min. - 3.05 in ³ /min at 210 bar - 3050 psi	0,275	0.61	see cavity SAE 10-3 page 172
EJ08B/3	12	3.1			BT see page 155	14 cm ³ /min. - 1.83 in ³ /min at 210 bar - 3050 psi	0,185	0.41	see cavity SAE 8-3 page 172
EJ08M/3	24**	6.3**	250**	3600**	BE/EC36 see page 157	40 cm ³ /min. - 2.44 in ³ /min. at 250 bar -3600 psi	0,125	0.27	

*with oil viscosity of 46 cst

**see the performance limit diagram

Dimensions and hydraulic circuit

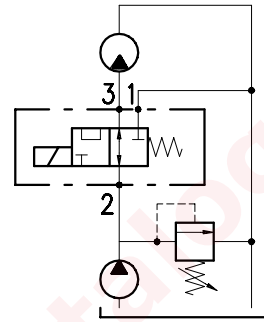
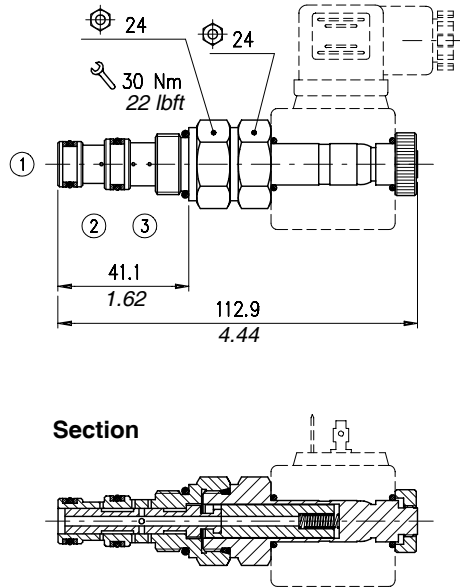

Rating diagrams

Typical pressure drop vs. flow characteristics

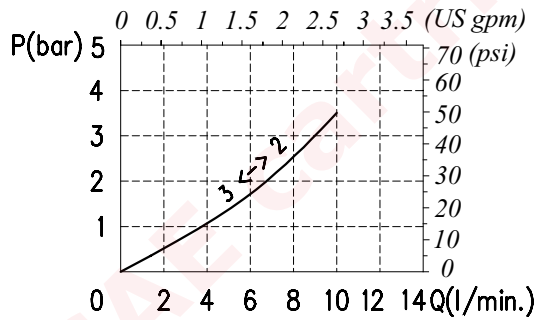

Typical pressure drop vs. flow characteristics

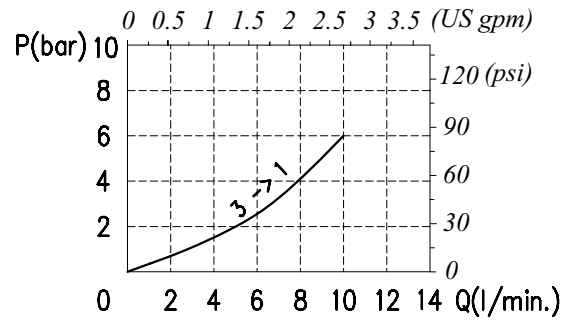

Order code

EJ 08A / 30 N □

Seals

B) Buna
V) Viton

Dimensions and hydraulic circuit

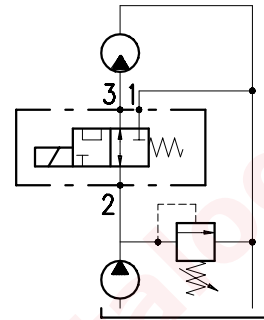
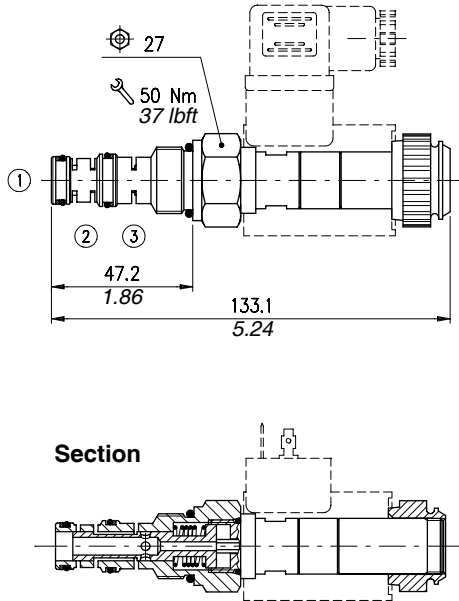

Rating diagrams

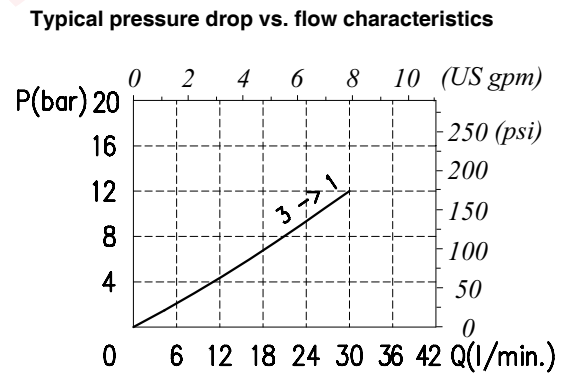
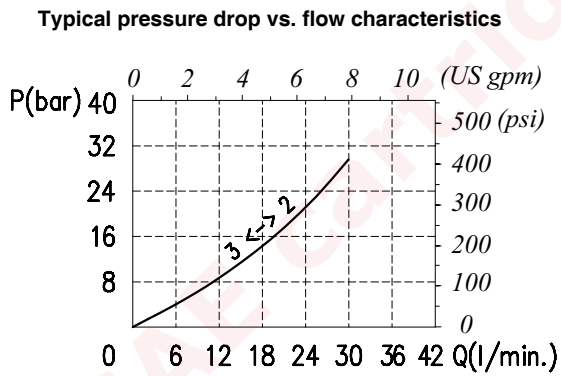

Order code

EJ 10A / 30 P □

Seals

- B) Buna
- V) Viton

Dimensions and hydraulic circuit

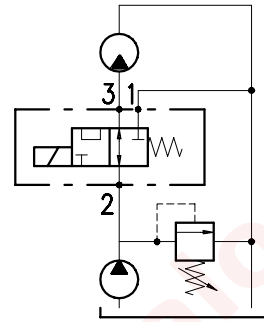
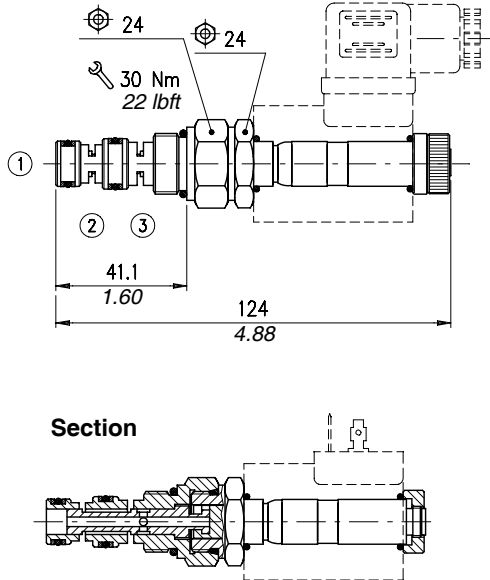

Rating diagrams

Typical pressure drop vs. flow characteristics

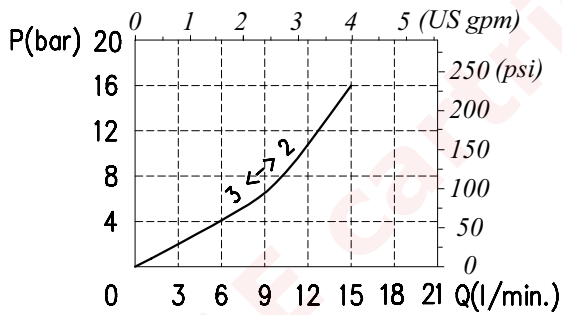

Typical pressure drop vs. flow characteristics

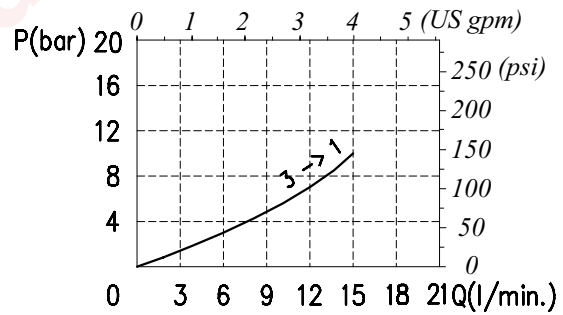

Order code

EJ 08B / 30 □ - □

Manual override option
(see page 163)

N) No emergency
T) Screw

Seals

B) Buna
V) Viton

Dimensions and hydraulic circuit

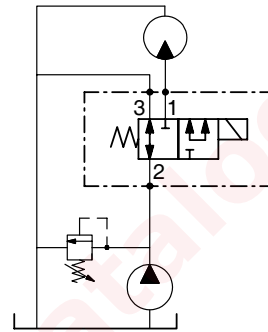
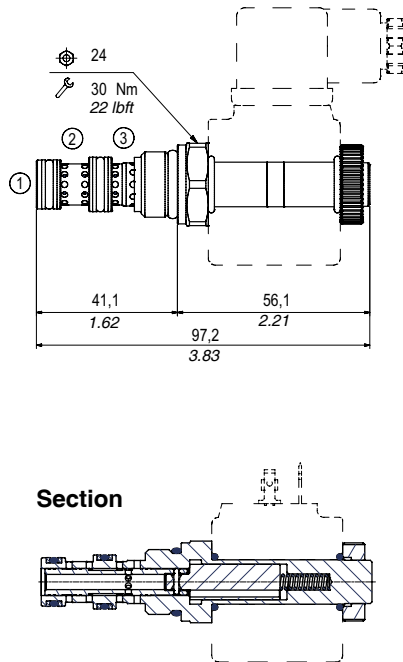

Rating diagrams

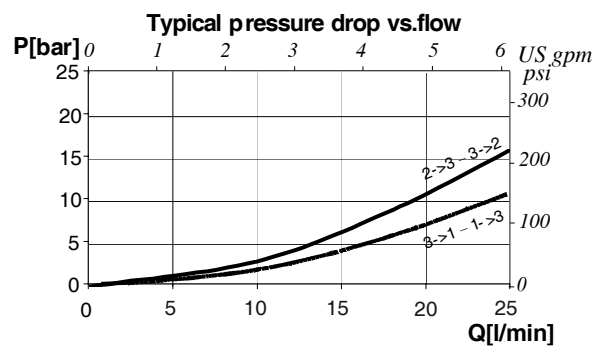
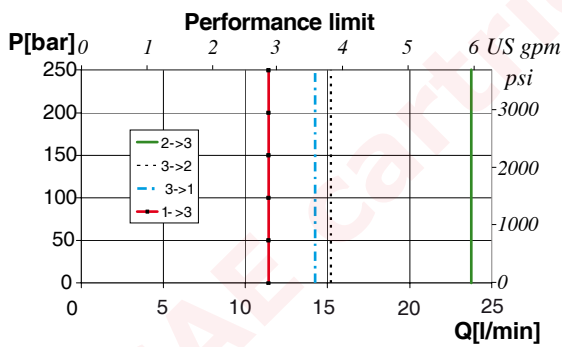

Order code

EJ08M/30 -

Manual override option
(see page 163)

- N)** No emergency (standard)
- F)** Pull button
- T)** With screw
- Q)** Pull button with safety lock

Seals

- B)** Buna
- V)** Viton



Operation

When the solenoid is deenergized the valve allows free oil flow from 2 to 1 and vice versa, while the way in 3 is sealed.

When the solenoid is energized the valve allows free oil flow from 3 to 2 and vice versa, while the way in 1 is sealed.

The way in 1 may not be used as discharge.

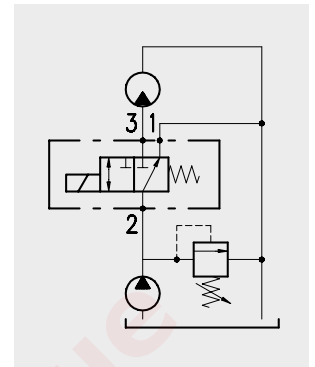

Performance

Cartridges

Type	Maximum flow		Maximum pressure		Solenoids	*Oil leaks from 1 to 2	Weight		Cavities and tools
	l/min	US gpm	bar	psi			kg	lb	
EJ08A/4	10	2.6	210	3050	BE/EC36 see page 157	10 cm ³ /min. - 0.61 in ³ /min at 210 bar - 3050 psi	0,175	0.38	see cavity SAE 8-3 page 172
EJ10A/4	30	8			BIN 19 see page 158	50 cm ³ /min. - 3.05 in ³ /min at 210 bar - 3050 psi	0,275	0.61	see cavity SAE 10-3 page 172
EJ12A/4	40	10.5			BIN 22 see page 159	120 cm ³ /min. - 7.32 in ³ /min at 210 bar - 3050 psi	0,500	1.10	see cavity SAE 12-3 page 172
EJ10B/4	20	5.3			BC 16 see page 160	75 cm ³ /min. - 4.58 in ³ /min at 210 bar - 3050 psi	0,285	0.63	see cavity SAE 10-3 page 172
EJ08M/4	25**	6.6**	250**	3600**	BE/EC36 see page 157	40 cm ³ /min. - 2.44 in ³ /min at 250 bar - 3600 psi	0,125	0.27	see cavity SAE 8-3 page 172

*with oil viscosity of 46 cst

**see the performance limit diagram

Dimensions and hydraulic circuit

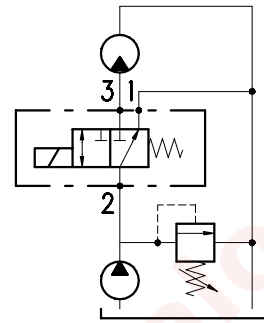
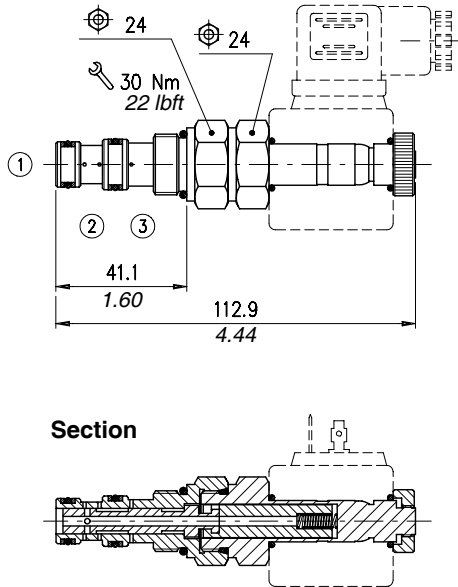

Rating diagrams

Typical pressure drop vs. flow characteristics

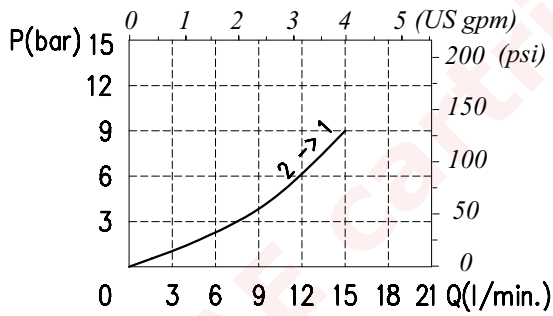

Typical pressure drop vs. flow characteristics

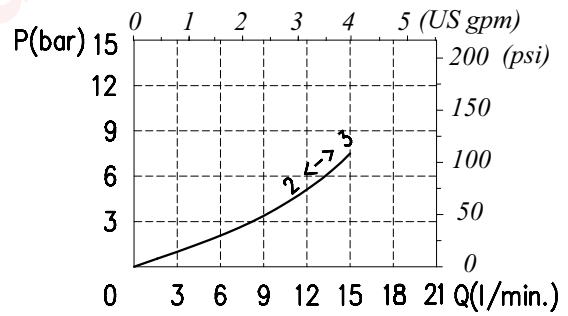

Order code

EJ 08A / 40 N □

Seals

B) Buna
V) Viton

Dimensions and hydraulic circuit

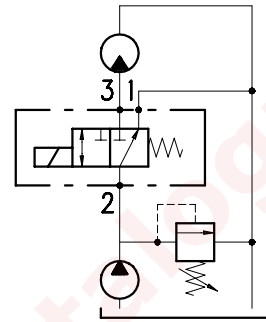
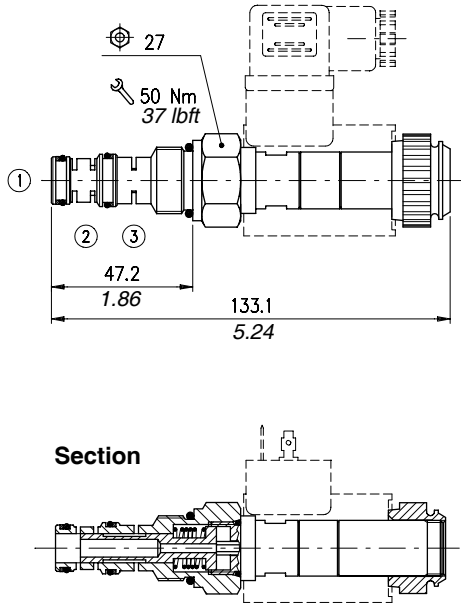

Rating diagrams

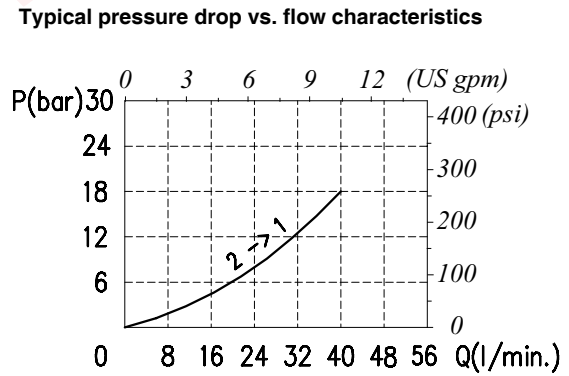
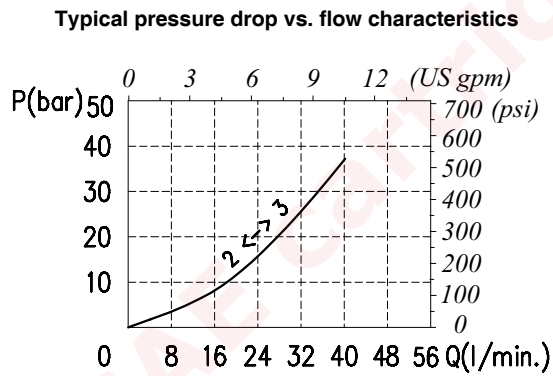

Order code

EJ 10A / 40 P □

Seals

- B) Buna
- V) Viton

Dimensions and hydraulic circuit

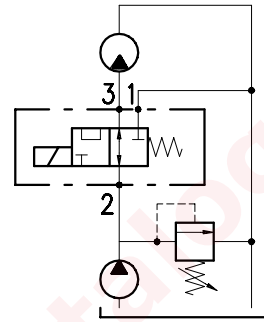
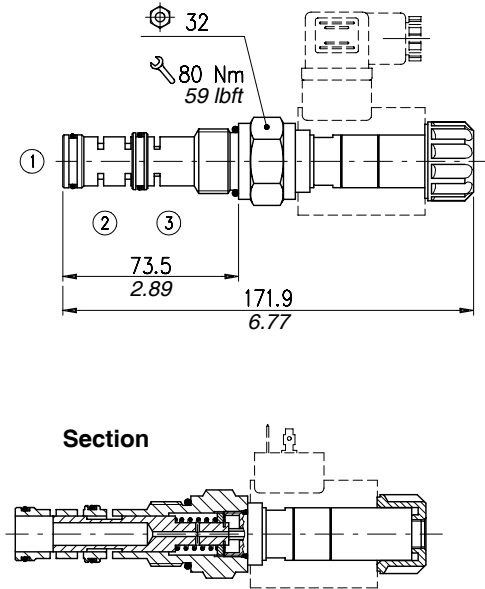

Rating diagrams

Typical pressure drop vs. flow characteristics

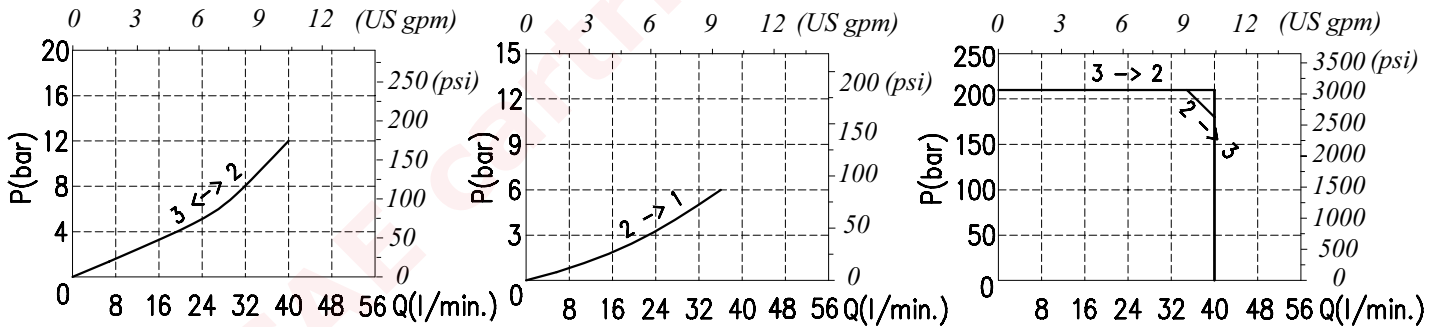

Order code

EJ 12A / 40 P □

Seals

B) Buna
V) Viton

Dimensions and hydraulic circuit

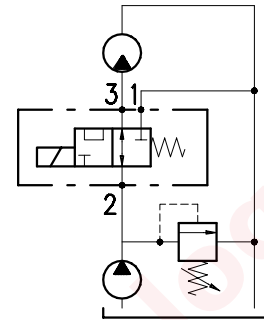
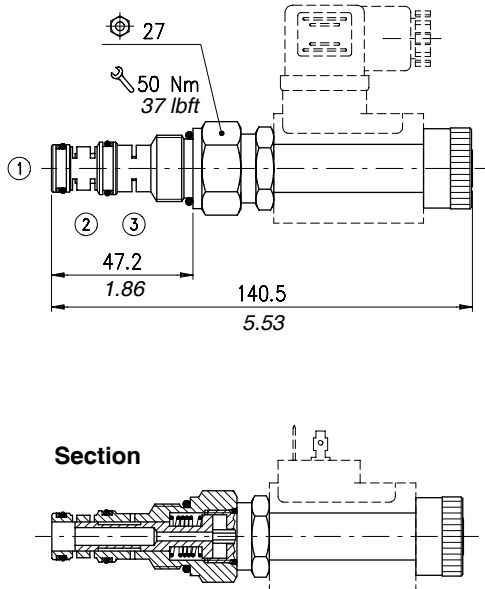

Rating diagrams

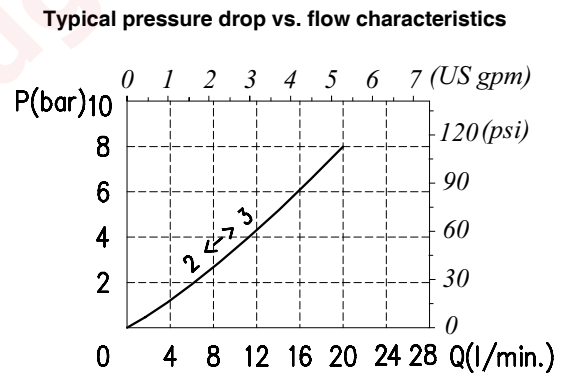
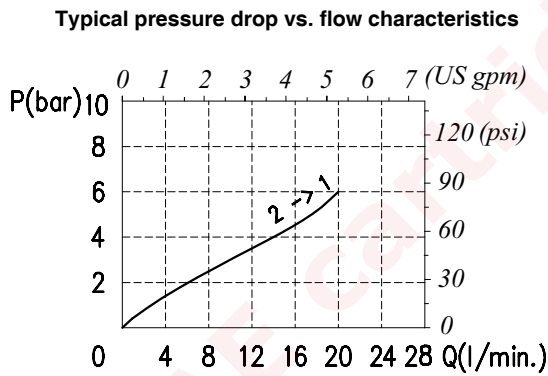

Order code

EJ 10B / 40 N □

Seals

B) Buna
V) Viton

Dimensions and hydraulic circuit

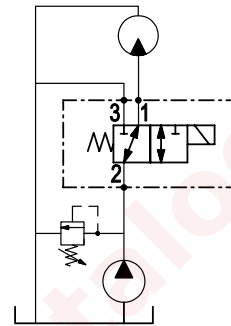
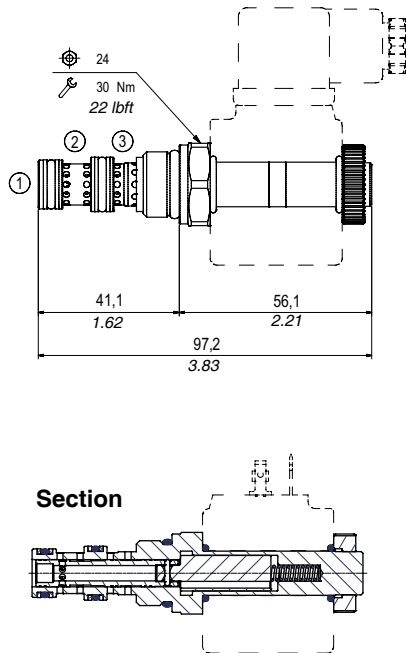

Rating diagrams

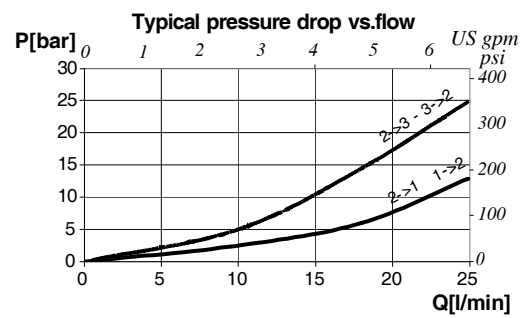
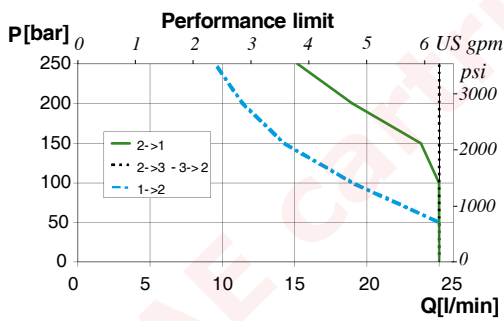

Order code

EJ08M/40 -

Manual override option
(see page 163)

- N**) No emergency (standard)
- F**) Pull button
- T**) With screw
- Q**) Pull button with safety lock

Seals

- B**) Buna
- V**) Viton

Operation

When the solenoid is deenergized the valve allows free oil flow from 2 to 1 and vice versa, while the way in 3 is sealed.

When the solenoid is energized the valve allows free oil flow from 3 to 2 and vice versa, while the way in 1 is sealed.

The way in 1 may not be used as discharge.

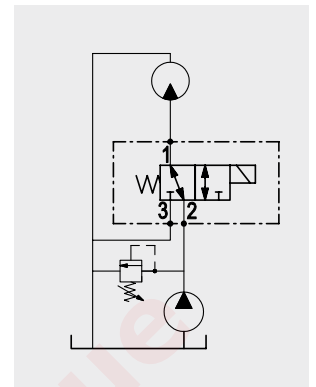

Performance

Cartridges

Type	Maximum flow		Maximum pressure		Solenoids	*Oil leaks from 1 to 2	Weight		Cavities and tools
	l/min	US gpm	bar	psi			kg	lb	
EJ08M/5	25**	6.6**	250**	3600**	BE/EC36 see page 157	40 cm ³ /min. - 2.44 in ³ /min. at 250 bar -3600 psi	0,125	0.27	see cavity SAE 8-3 page 172

*with oil viscosity of 46 cst

**see the performance limit diagram

Dimensions and hydraulic circuit

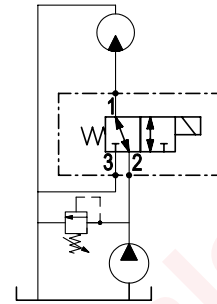
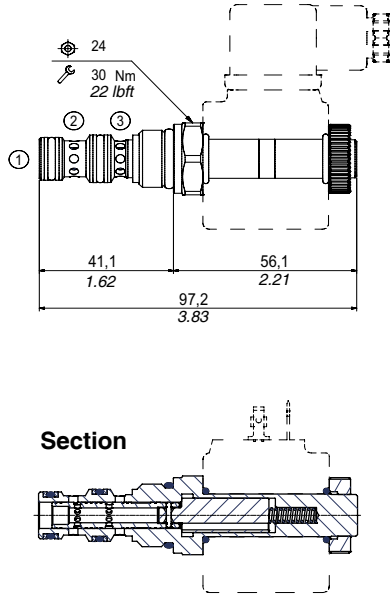

Rating diagrams

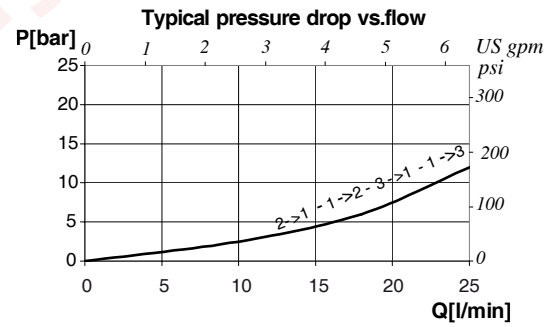
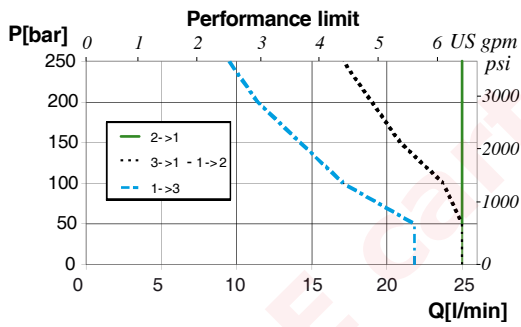

Order code

EJ08M/50 -

Manual override option
(see page 163)

- N**) No emergency (standard)
- F**) Pull button
- T**) With screw
- Q**) Pull button with safety lock

Seals

- B**) Buna
- V**) Viton

Operation

When the solenoid is deenergized the valve allows free oil flow from 1 to 3 while the way in 2 is sealed.
When the solenoid is energized the valve allows free oil flow from 2 to 1 while the way in 3 is sealed.

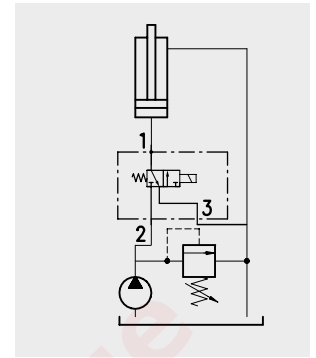

Performance

Cartridges

Type	Maximum flow		Maximum pressure		Solenoids	*Oil leaks from 1 to 2	Weight		Cavities and tools
	l/min	US gpm	bar	psi			kg	lb	
EJ08F/2	12	3.17	50	725	BT/CS see page 155	5 cm ³ /min. - 0.3 in ³ /min at 50 bar - 725 psi	0,175	0.38	See cavity SAE 8-3 page 172

*with oil viscosity of 46 cst

Dimensions and hydraulic circuit

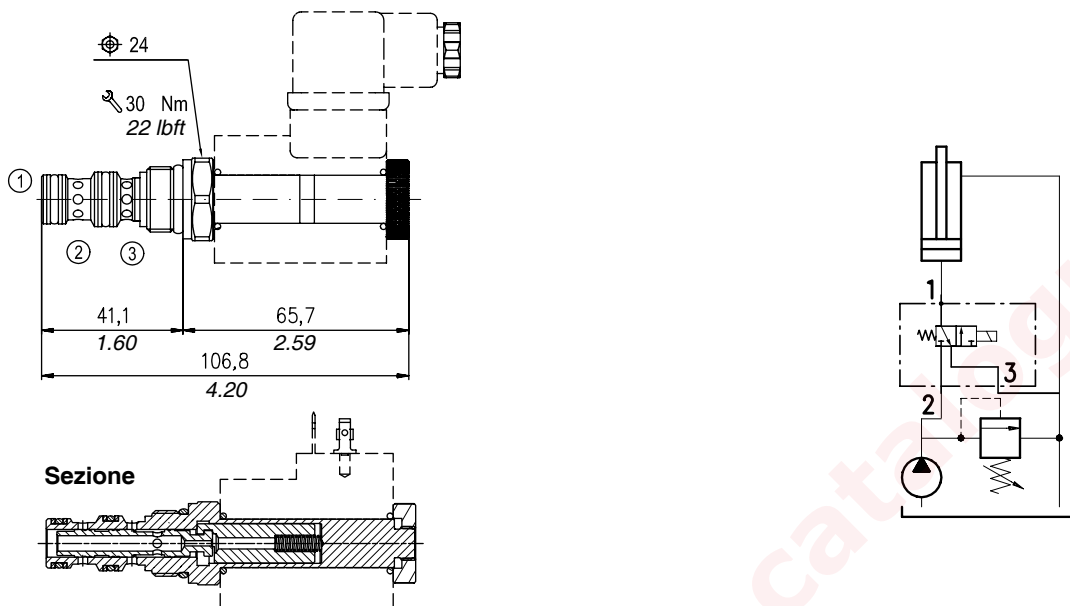

Rating diagrams

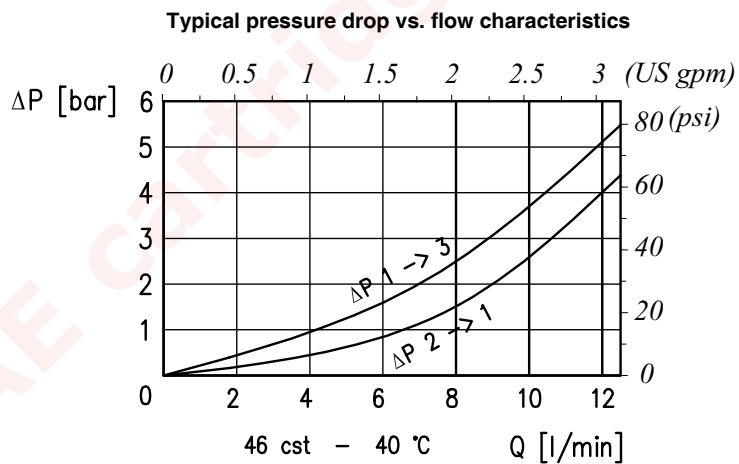

Order code

EJ 08F / 20 N □

Manual override option
(see page 163)

N) No emergency (standard)
T) Screw

Seals

B) Buna
V) Viton

Operation

When the solenoid is deenergized the valve allows free oil flow from 3 to 2 and from 4 to 1.
When the solenoid is energized the valve allows free oil flow from 3 to 4 and from 2 to 1.

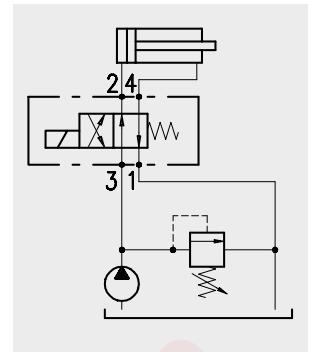

Performance

Cartridges

Type	Maximum flow		Maximum pressure		Solenoids	*Oil leaks from 1 to 2	Weight		Cavities and tools
	l/min	US gpm	bar	psi			kg	lb	
ER08M/1	18	4.7	210	3050	BE/EC 36 see page 157	40 cm ³ /min. - 2.44 in ³ /mm at 210 bar - 3050 psi	0,200	0.44	see cavity SAE 8-4 page 173
ER10A/1	30	8			BIN 19 see page 158	100 cm ³ /min. - 6.10 in ³ /mm at 210 bar - 3050 psi	0,380	0.84	see cavity SAE 10-4 page 173
ER10B/1	20	5.3			BC 16 see page 160	30 cm ³ /min. - 1.83 in ³ /mm at 210 bar - 3050 psi	0,310	0.68	
ER10M/1	40	10.5			BC 16 see page 160	80 cm ³ /min. - 4.88 in ³ /mm at 210 bar - 3050 psi	0,45	0.99	
ER12A/1					BIN 22 see page 159	200 cm ³ /min. - 12.20 in ³ /mm at 210 bar - 3050 psi	0,49	1.08	

*with oil viscosity of 46 cst

Dimensions and hydraulic circuit

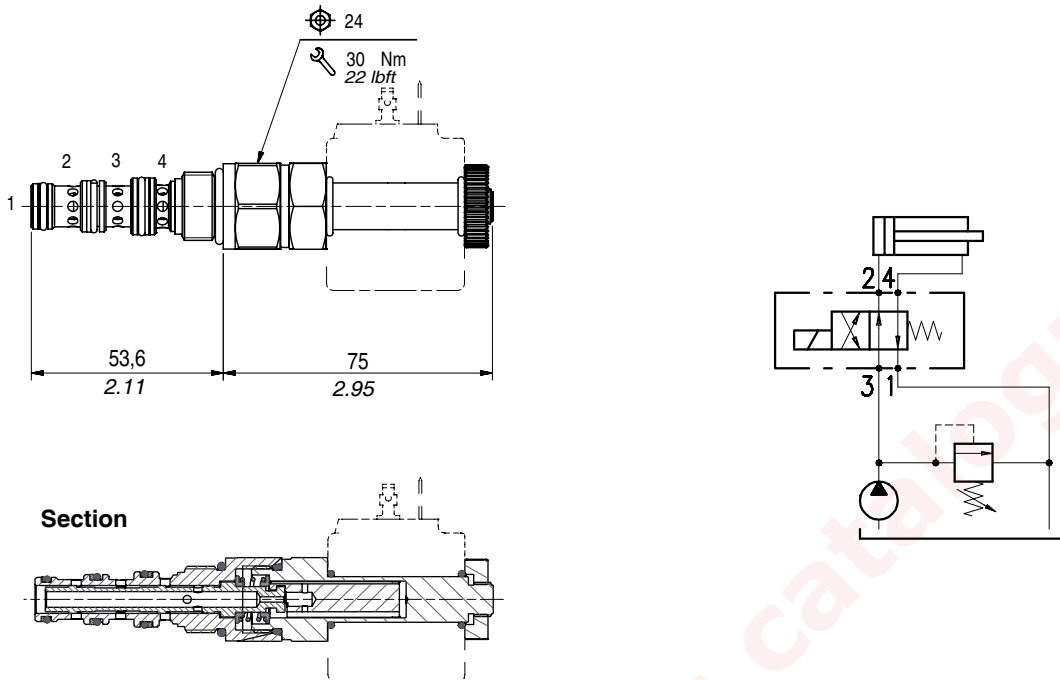

Rating diagrams

Typical pressure drop vs. flow characteristics

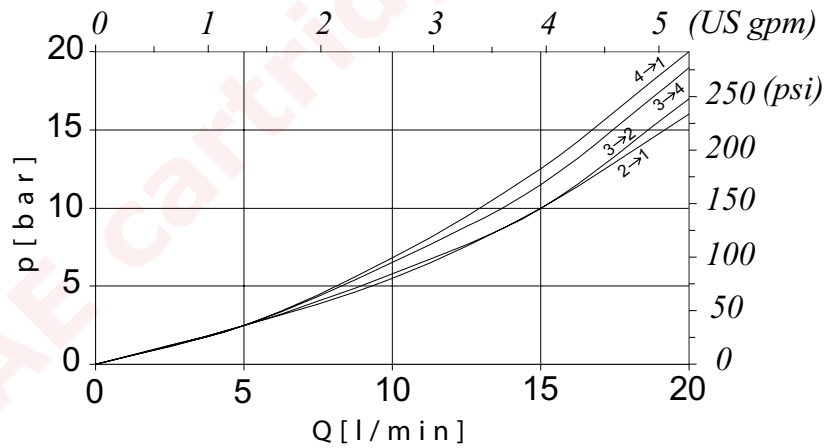

Order code

ER 08M / 10 N □

Seals

B) Buna
V) Viton

Dimensions and hydraulic circuit

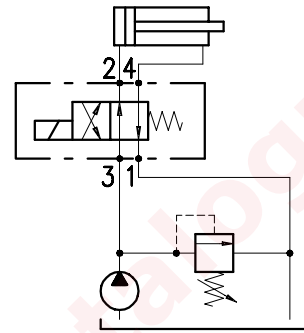
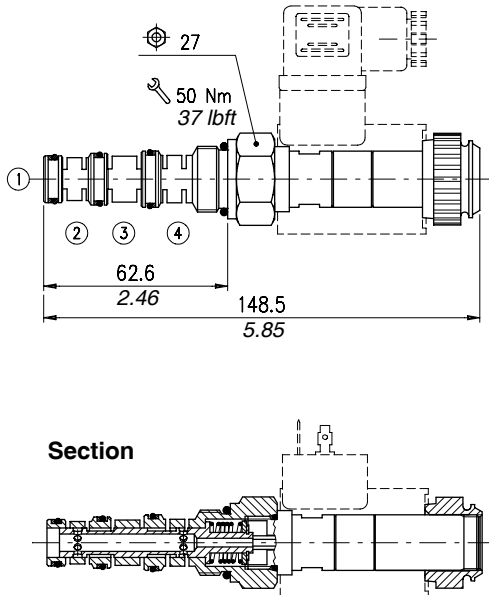

Rating diagrams

Typical pressure drop vs. flow characteristics

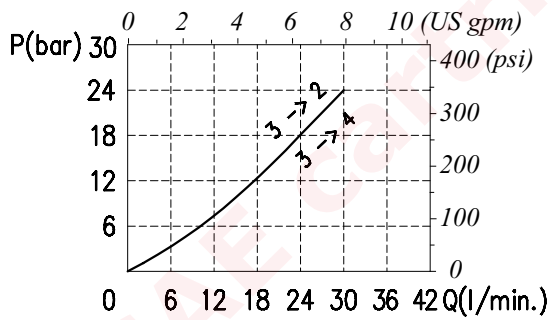

Typical pressure drop vs. flow characteristics

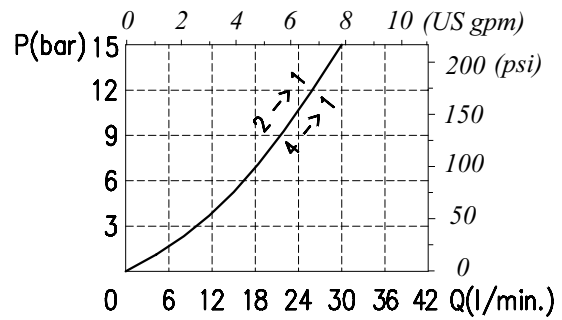

Order code

ER 10A / 10 P □

Seals

- B) Buna**
- V) Viton**

Dimensions and hydraulic circuit

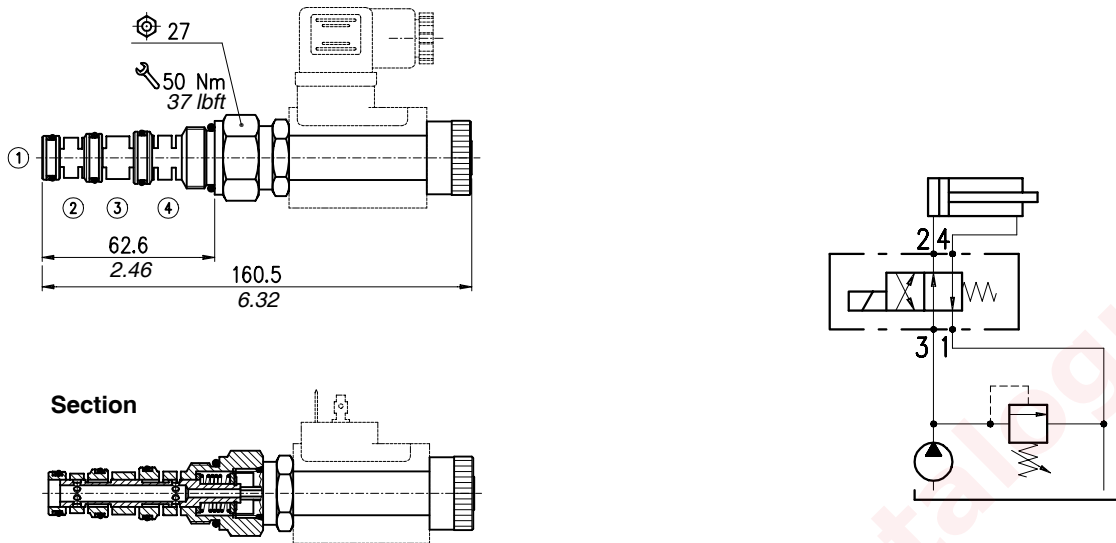

Rating diagrams

Typical pressure drop vs. flow characteristics

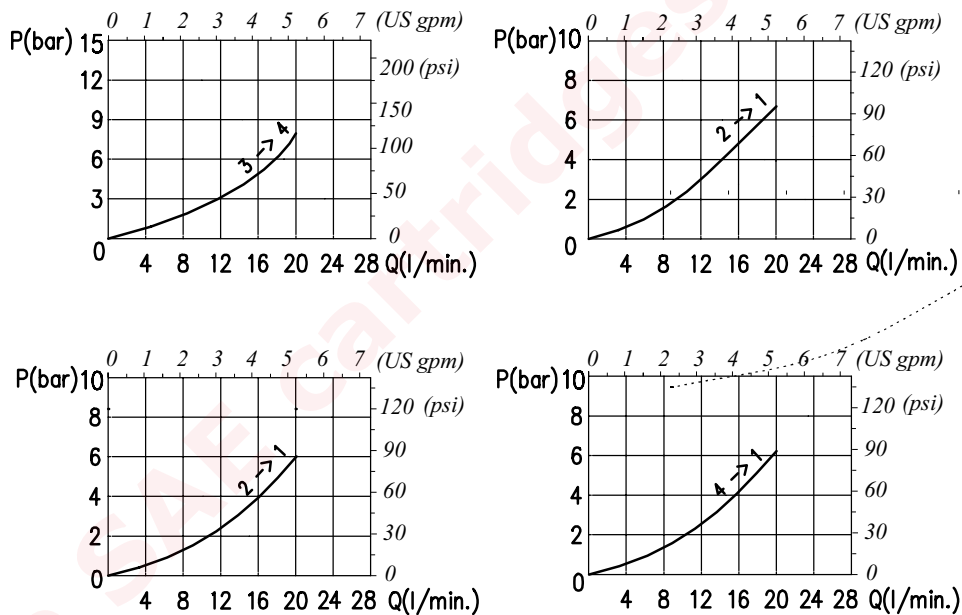

Order code

ER 10B / 10 □ - □

Manual override option

(see page 163)

N) No emergency (standard)
P) Button

Seals

B) Buna
V) Viton

Dimensions and hydraulic circuit

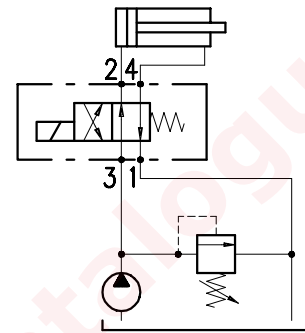
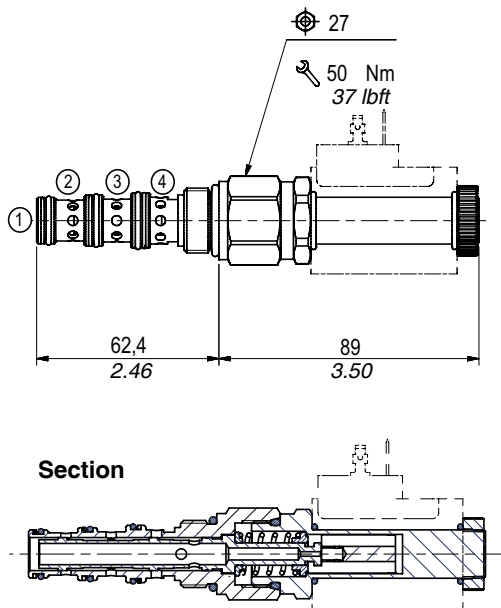

Rating diagrams

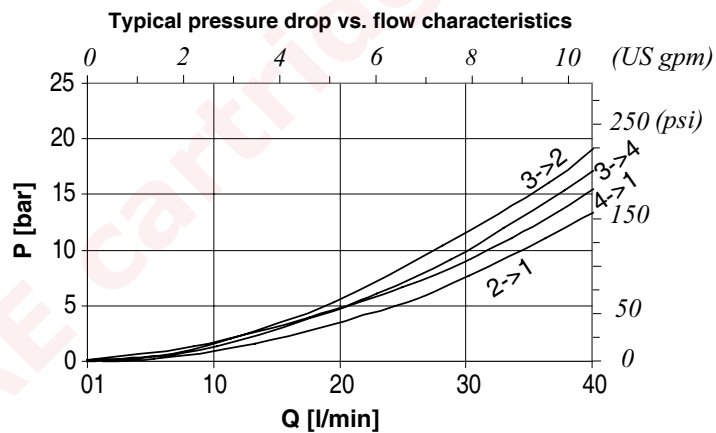

Order code

ER 10M / 10 □ □

Manual override option
(see page 163)

N) No emergency (standard)
T) Screw
F) Pull button

Seals

B) Buna
V) Viton

Dimensions and hydraulic circuit

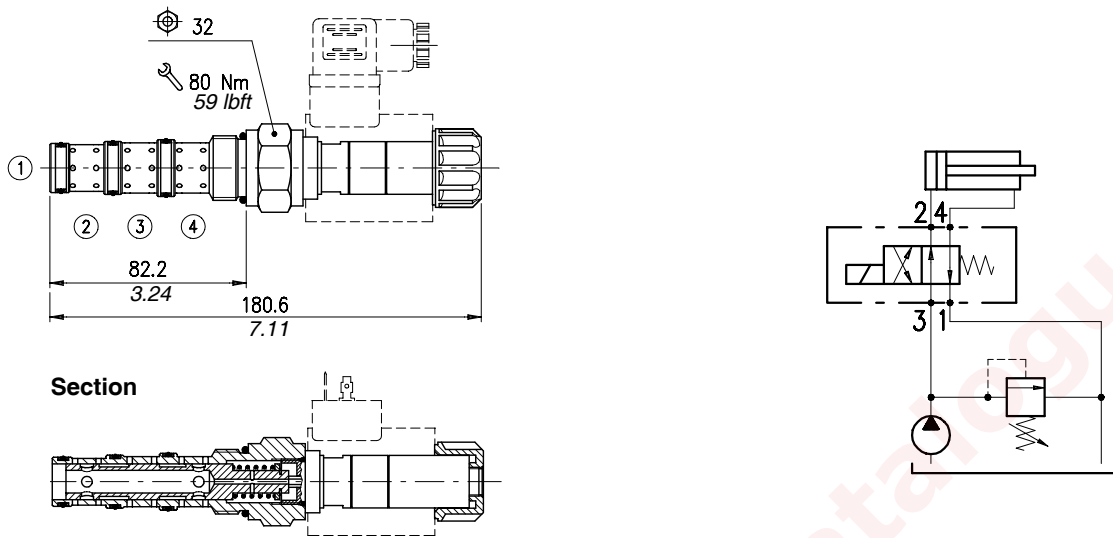

Rating diagrams

Typical pressure drop vs. flow characteristics

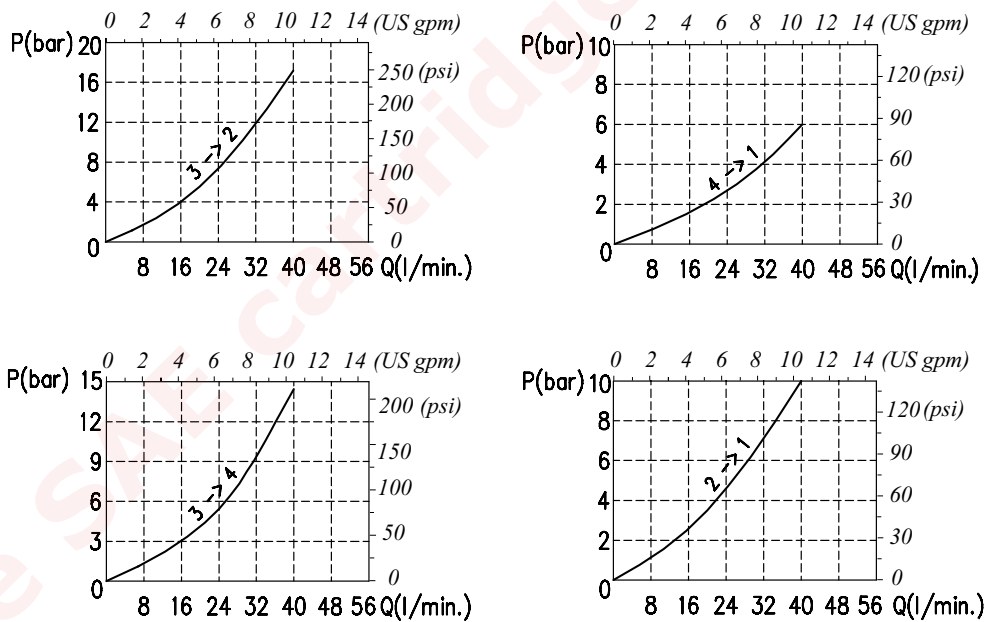

Order code

ER 12A / 10 P □

Seals

B) Buna
V) Viton

Operation

When the spool is deenergized the valve allows free oil flow from 3 to 2 and from 4 to 1.
When the solenoid is energized all ways are sealed.

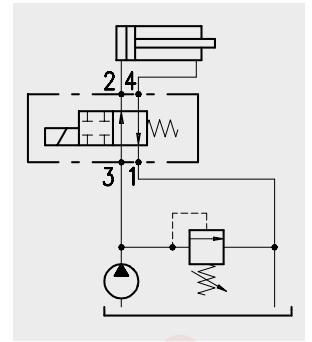

Performance

Cartridges

Type	Maximum flow		Maximum pressure		Solenoids	*Oil leaks from 1 to 2	weight		Cavities and tools
	l/min	US gpm	bar	psi			kg	lb	
ER08M/2	20	5.3	210	3050	BE/EC 36 see page 157	40 cm ³ /min. - 2.44 in ³ /min at 210 bar - 3050 psi	0,200	0.44	see cavity SAE 8-4 page 173
ER10M/2	45	12			BC 16 see page 160	80 cm ³ /min. - 4.88 in ³ /min at 210 bar - 3050 psi	0,45	0.99	see cavity SAE 10-4 page 173
ER12A/2	40	10.5			BIN 22 see page 159	200 cm ³ /min. - 12.2 in ³ /min at 210 bar - 3050 psi	0,490	1.08	see cavity SAE 12-4 page 173
ER10B/2	20	5.3			BC 16 see page 160	30 cm ³ /min. - 1.83 in ³ /min at 210 bar - 3050 psi	0,310	0.68	see cavity SAE 10-4 page 173

*with oil viscosity of 46 cst

Dimensions and hydraulic circuit

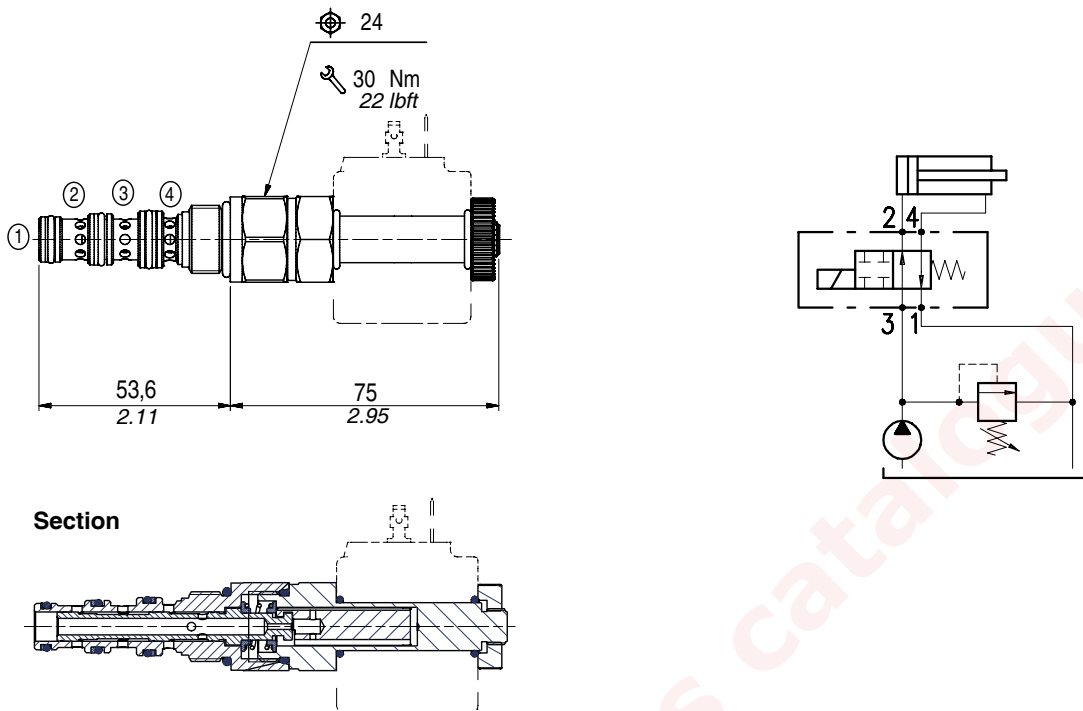

Rating diagrams

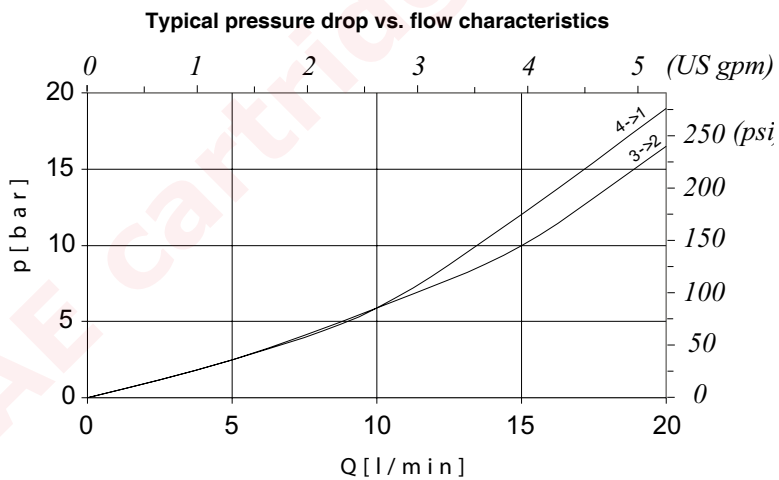

Order code

ER 08M / 20 N □

Seals

B) Buna
V) Viton

Dimensions and hydraulic circuit

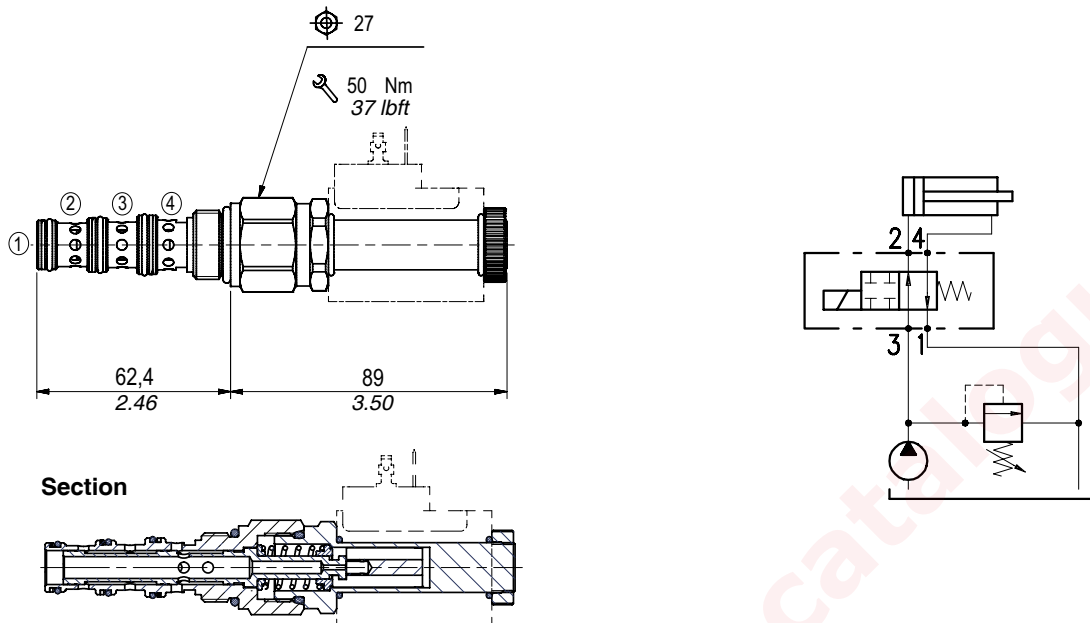

Rating diagrams

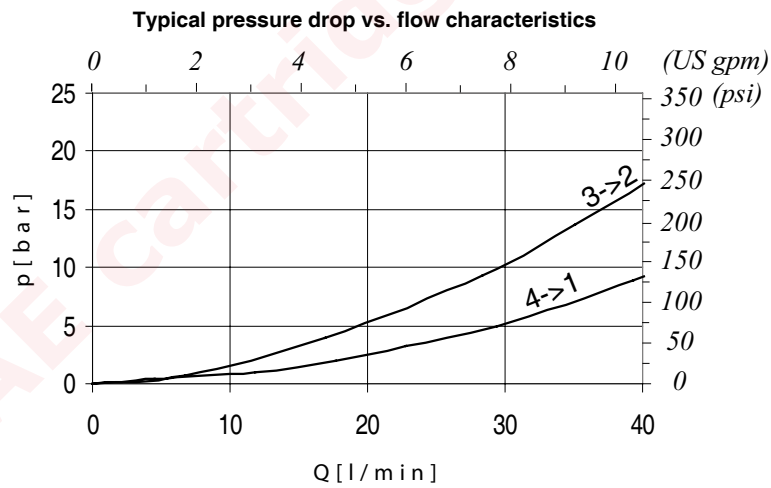

Order code

ER 10M / 20 □ □

Manual override option

(see page 163)

- N)** No emergency (standard)
- T)** Screw
- F)** Pull button

Seals

- B)** Buna
- V)** Viton

Dimensions and hydraulic circuit

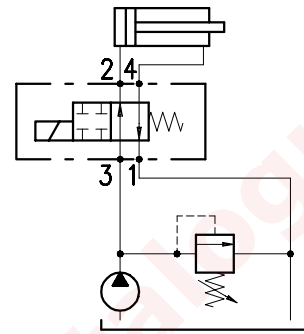
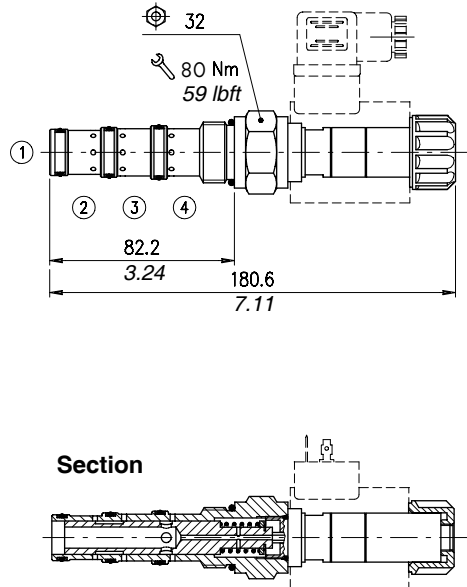

Rating diagrams

For rating diagrams please ask
our technical office

Order code

ER 12A / 20 P □

Seals

B) Buna
V) Viton

Dimensions and hydraulic circuit

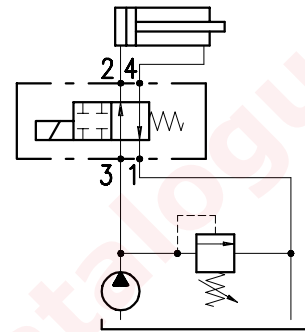
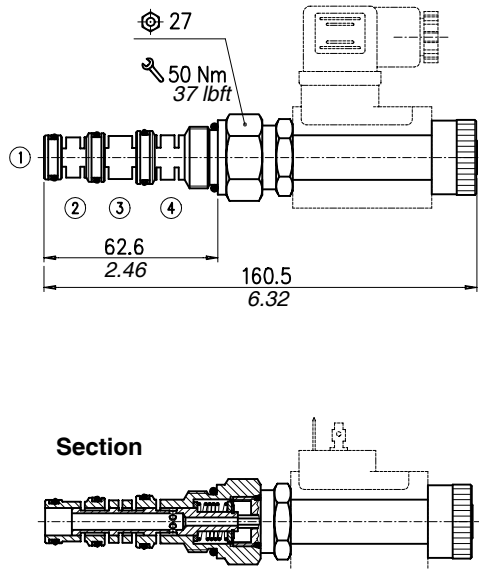

Rating diagrams

Typical pressure drop vs. flow characteristics

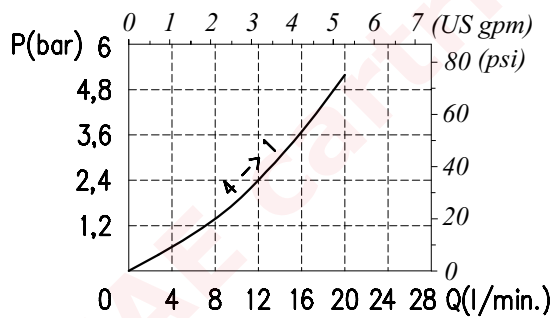

Typical pressure drop vs. flow characteristics

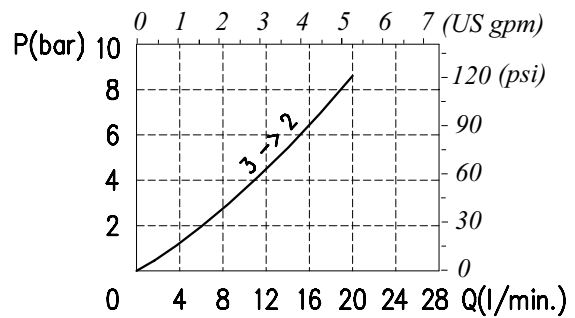

Order code

ER 10B / 20 □ - □

Manual override option
(see page 163)

N) No emergency (standard)
P) Button

Seals

B) Buna
V) Viton



Operation

When the spool is deenergized the valve keeps all ways shut.
When the solenoid is energized the valve allows free oil flow from 3 to 2 and from 4 to 1.

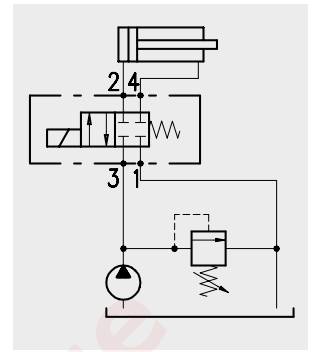

Performance

Cartidges

Type	Maximum flow		Maximum pressure		Solenoids	*Oil leaks from 1 to 2	Weight		Cavities and tools
	l/min	US gpm	bar	psi			kg	lb	
ER08M/3	18	4.7	210	3050	BE/EC 36 see page 157	40 cm ³ /min. - 2.44 in ³ /min at 210 bar - 3050 psi	0,200	0.44	see cavity SAE 8-4 page 173
ER10M/3	40	10.5			BC 16 see page 160	80 cm ³ /min. - 4.88 in ³ /min at 210 bar - 3050 psi	0,45	0.99	see cavity SAE 10-4 page 173
ER12A/3	40	10.5			BIN 22 see page 159	200 cm ³ /min. - 12.2 in ³ /min at 210 bar - 3050 psi	0,490	1.08	see cavity SAE 12-4 page 173
ER10B/3	20	5.3			BC 16 see page 160	20 cm ³ /min. - 1.22 in ³ /min at 210 bar - 3050 psi	0,310	0.68	see cavity SAE 10-4 page 173

*with oil viscosity of 46 cst

Dimensions and hydraulic circuit

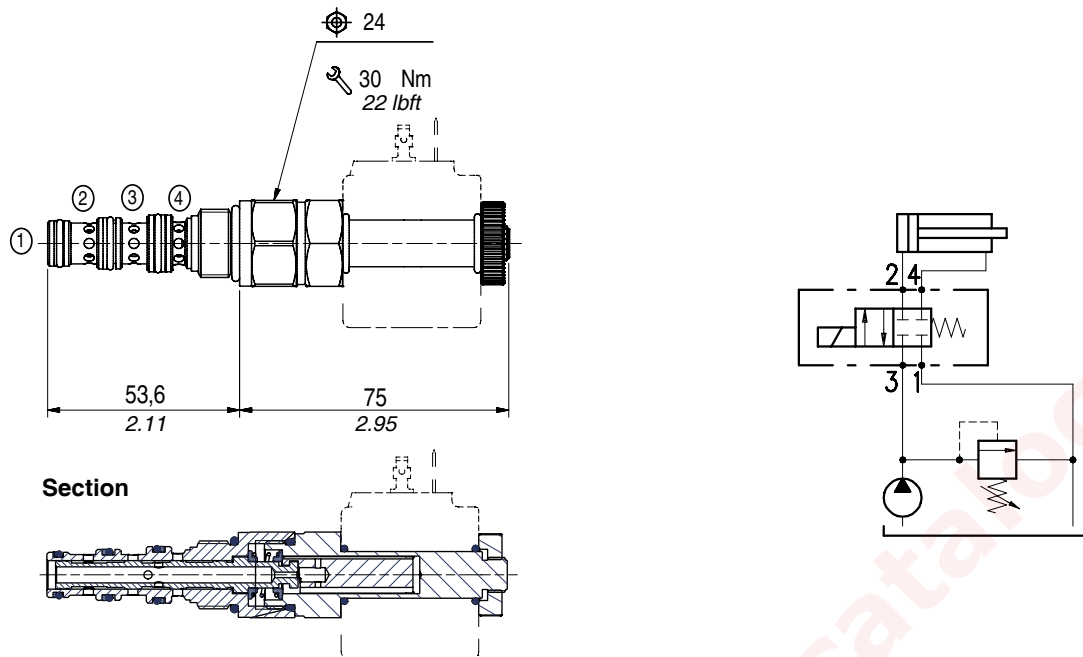

Rating diagrams

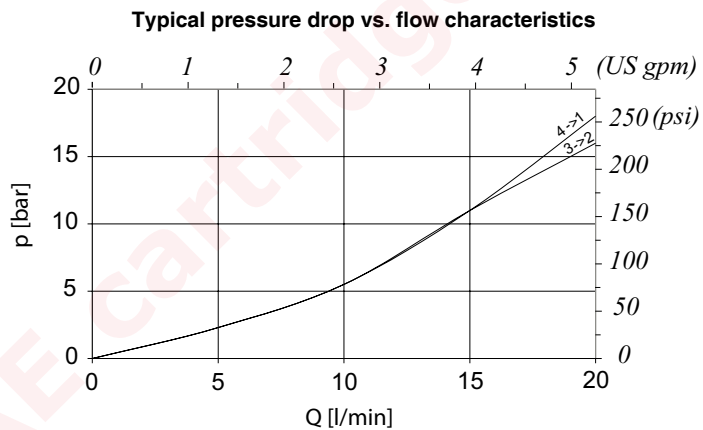

Order code

ER 08M / 30 N □

Seals

B) Buna
V) Viton

Dimensions and hydraulic circuit

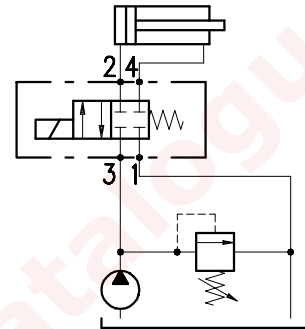
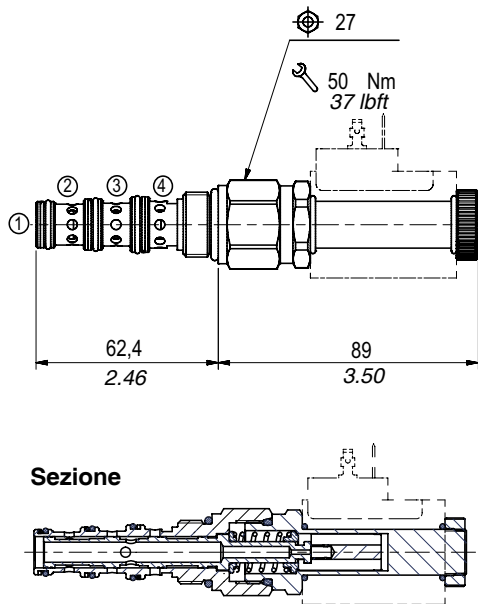

Rating diagrams

Typical pressure drop vs. flow characteristics

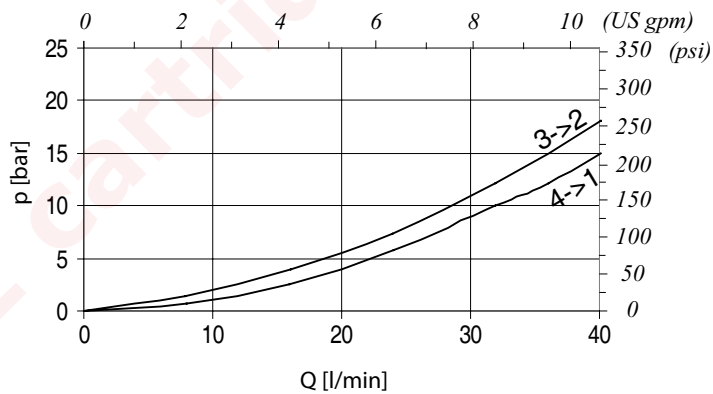

Order code

ER 10M / 30 □ □

Manual override option
(see page 163)

- N)** No emergency (standard)
- T)** Button
- F)** Screw

Seals

- B)** Buna
- V)** Viton

Dimensions and hydraulic circuit

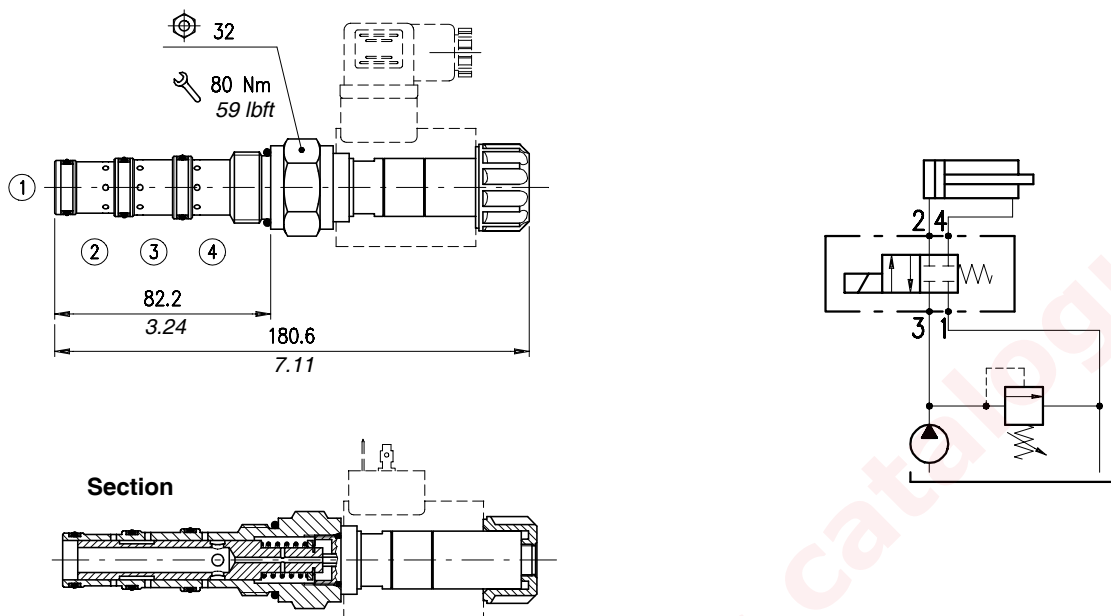

Rating diagrams

Typical pressure drop vs. flow characteristics

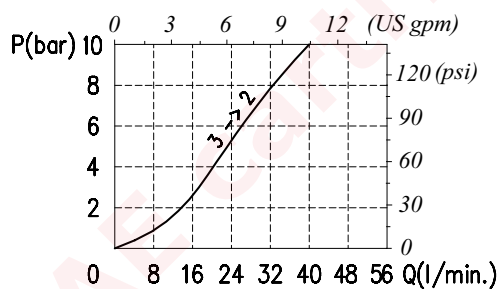

Typical pressure drop vs. flow characteristics

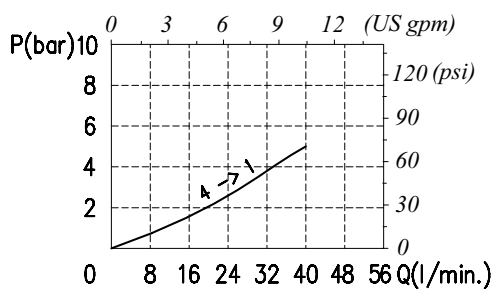

Order code

ER 12A / 30 P □

Seals

B) Buna
V) Viton

Dimensions and hydraulic circuit

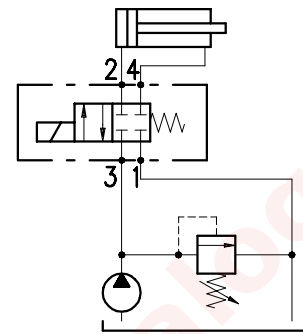
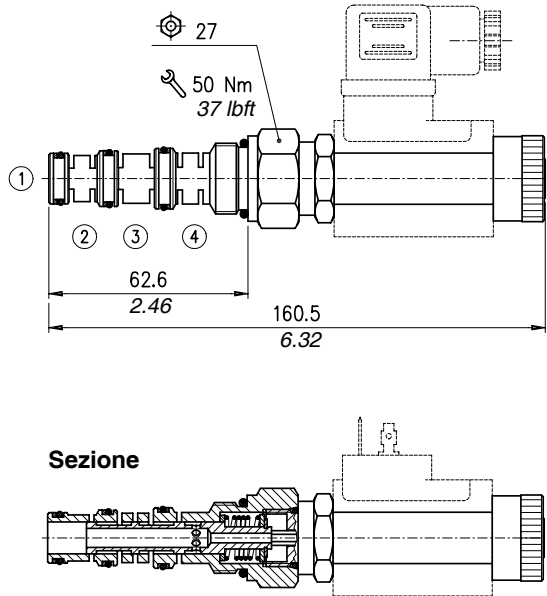

Rating diagrams

Typical pressure drop vs. flow characteristics

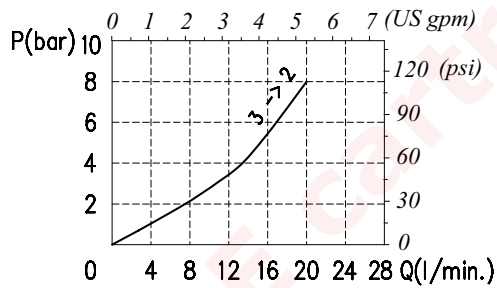

Typical pressure drop vs. flow characteristics

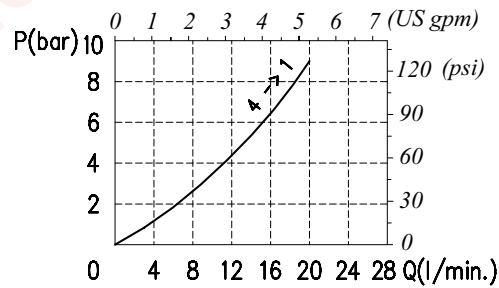

Order code

ER 10B / 30 □ - □

Manual override option
(see page 163)

N) No emergency (standard)
P) Button

Seals

B) Buna
V) Viton



Operation

Electric valve 4 ways, 2 positions, spool type.

When the spool is deenergized the valve provides for concurrent connection of all ways with each other.

When the solenoid is energized the valve allows free oil flow from 3 to 4 and from 2 to 1.

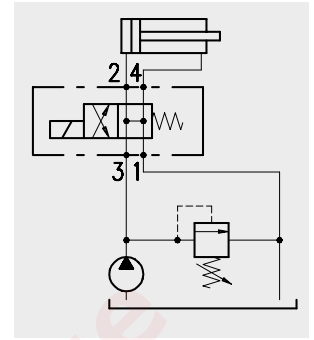

Performance

Cartridges

Type	Maximum flow		Maximum pressure		Solenoids	*Oil leaks from 1 to 2	Weight		Cavities and tools
	l/min	US gpm	bar	psi			kg	lb	
ER08M/4	18	4.7	210	3050	BE/EC 36 see page 157	40 cm ³ /min. - 2.44 in ³ /min at 210 bar - 3050 psi	0,200	0.44	see cavity SAE 8-4 page 173
ER10M/4	40	10.5			BC 16 see page 160	80 cm ³ /min. - 4.88 in ³ /min at 210 bar - 3050 psi	0,45	0.99	see cavity SAE 10-4 page 173
ER10B/4	20	5.3			BC 16 see page 160	30 cm ³ /min. - 1.92 in ³ /min at 210 bar - 3050 psi	0,310	0.68	see cavity SAE 10-4 page 173
ER12A/4	40	10.5			BIN 22 see page 159	200 cm ³ /min. - 12.2 in ³ /min at 210 bar - 3050 psi	0,490	1.08	see cavity SAE 12-4 page 173

*with oil viscosity of 46 cst

Dimensions and hydraulic circuit

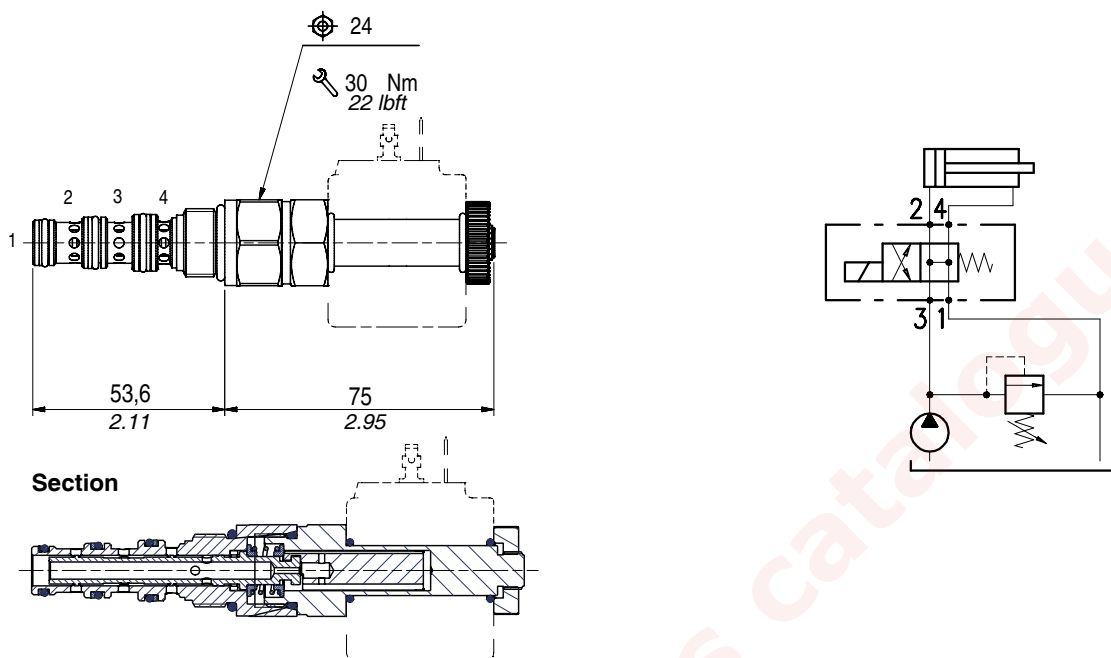

Rating diagrams

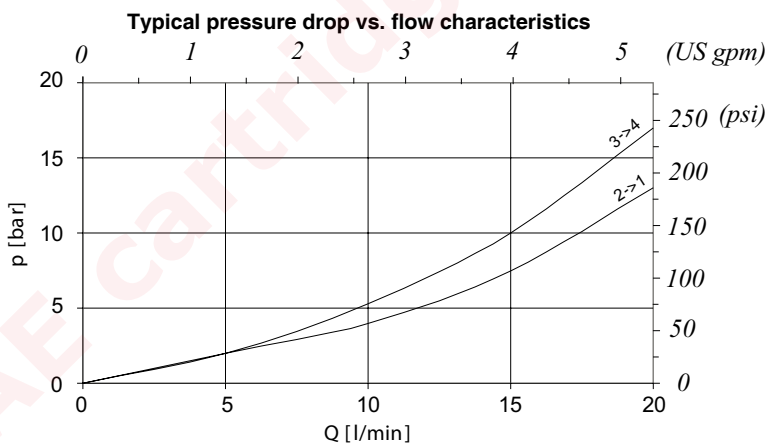

Order code

ER 08M / 40 N □

Seals

B) Buna
V) Viton

Dimensions and hydraulic circuit

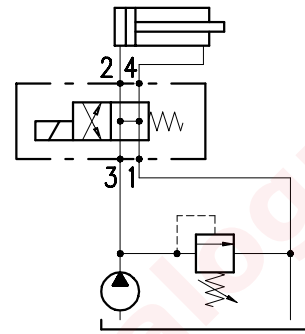
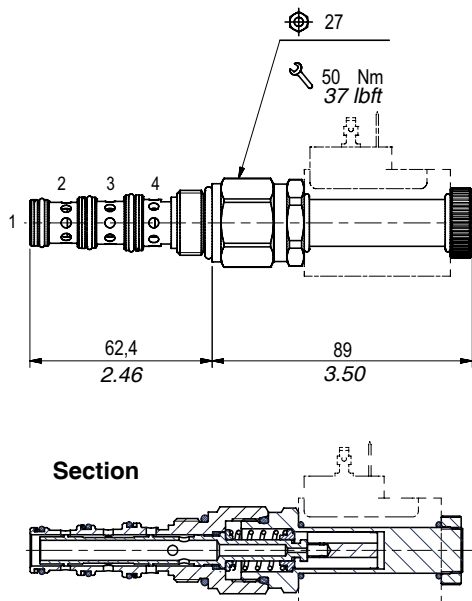

Rating diagrams

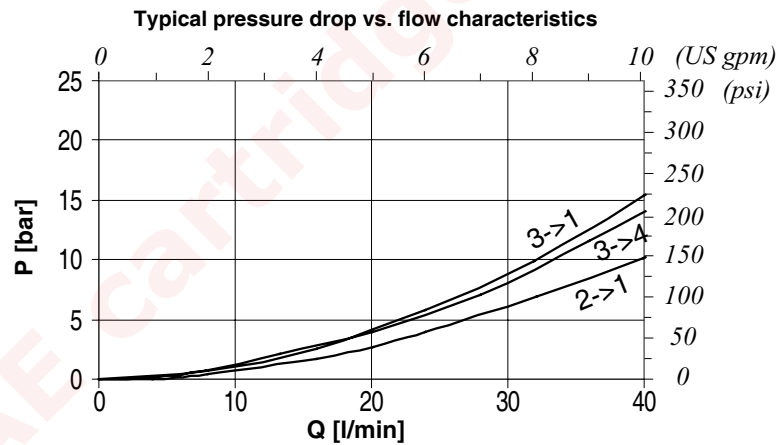

Order code

ER 10M / 40 □ □

Manual override option
(see page 163)

- N)** No emergency (standard)
- T)** Screw
- F)** Pull button

Seals

- B)** Buna
- V)** Viton

Dimensions and hydraulic circuit

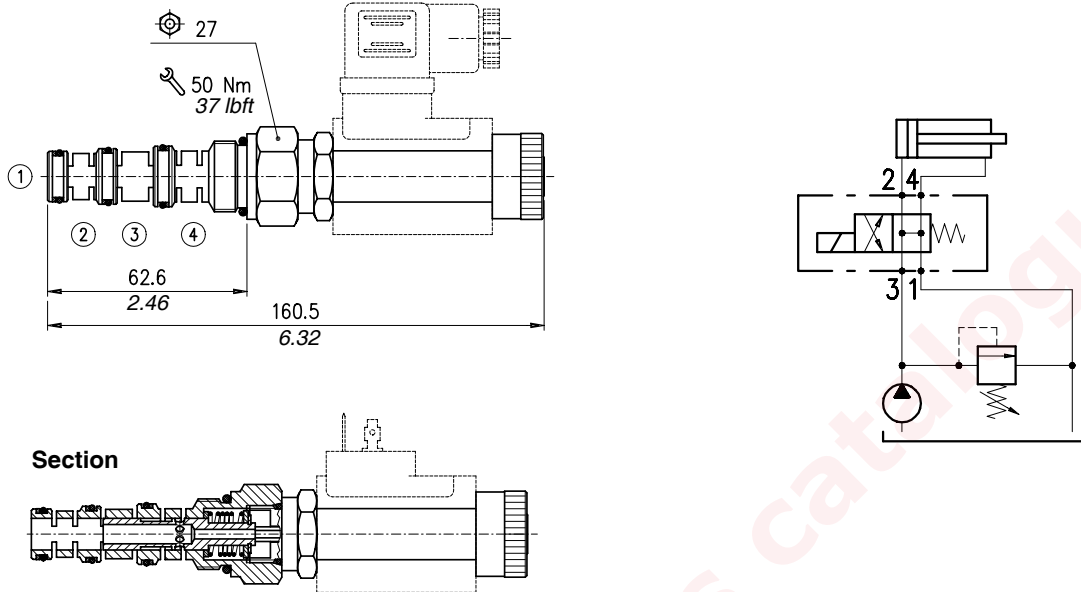

Rating diagrams

Typical pressure drop vs. flow characteristics

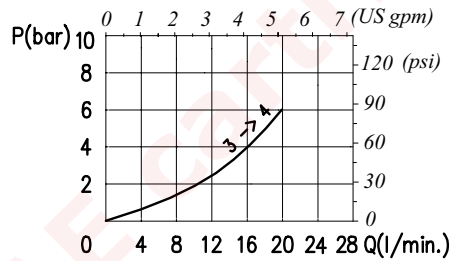

Typical pressure drop vs. flow characteristics

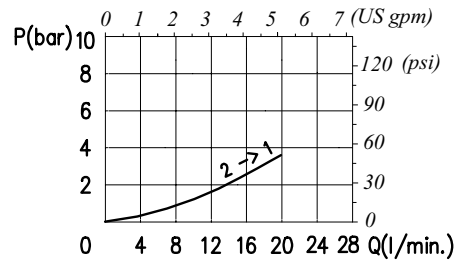

Order code

ER 10B / 40 □ - □

Manual override option
(see page 163)

N) No emergency (standard)
P) Button

Seals

B) Buna
V) Viton

Dimensions and hydraulic circuit

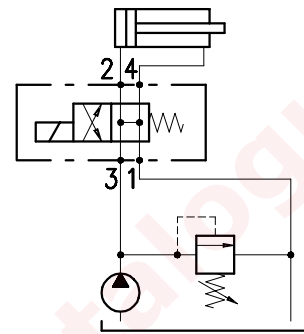
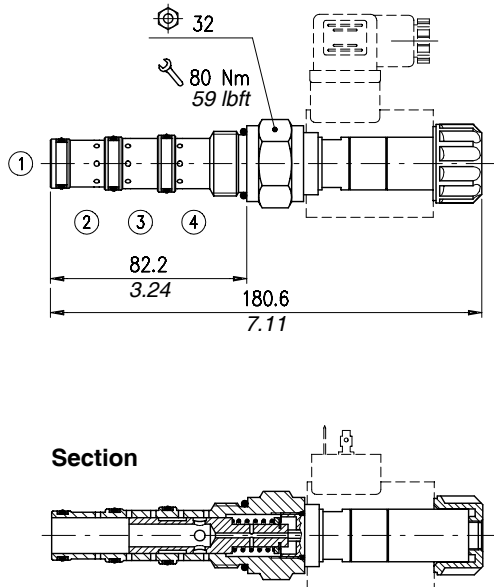

Rating diagrams

Typical pressure drop vs. flow characteristics

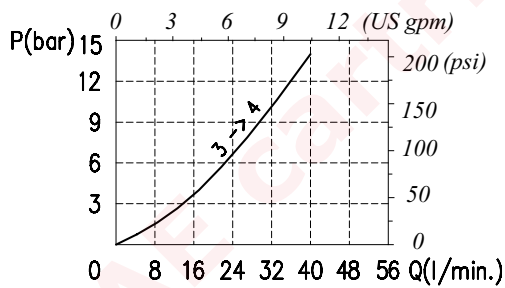

Typical pressure drop vs. flow characteristics

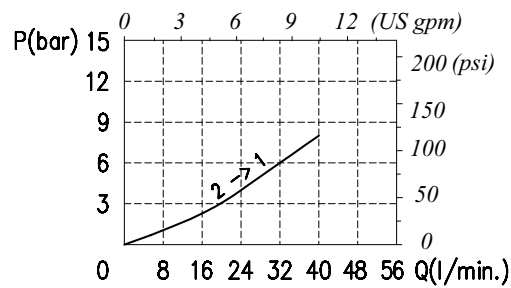

Order code

ER 12A / 40 P □

Seals

- B) Buna
- V) Viton



Operation

When the spool is deenergized the valve keeps all ways shut.
When the solenoid is energized the valve allows free oil flow from 3 to 4 and from 2 to 1.

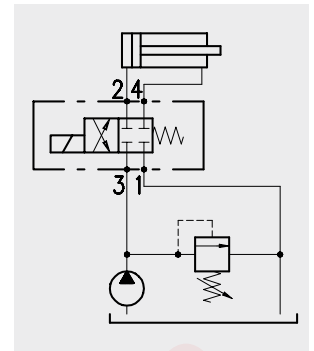

Performance

Cartridges

Type	Maximum flow		Maximum pressure		Solenoids	*Oil leaks from 1 to 2	Weight		Cavity and tools
	l/min	US gpm	bar	psi			kg	lb	
ER08M/5	18	4.7	210	3050	BE/EC 36 see page 157	40 cm ³ /min. - 2.44 in ³ /min at 210 bar - 3050 psi	0,200	0.44	see cavity SAE 8-4 page 173
ER10M/5	40	10.5			BC 16 see page 160	80 cm ³ /min. - 4.88 in ³ /min at 210 bar - 3050 psi	0,45	0.99	see cavity SAE 10-4 page 173
ER10A/5	30	8			BIN 19 see page 158	30 cm ³ /min. - 1.92 in ³ /min at 210 bar - 3050 psi	0,380	0.84	
ER12A/5	40	10.5			BIN 22 see page 159	30 cm ³ /min. - 1.92 in ³ /min at 210 bar - 3050 psi	0,490	1.08	see cavity SAE 12-4 page 173

*with oil viscosity of 46 cst

Dimensions and hydraulic circuit

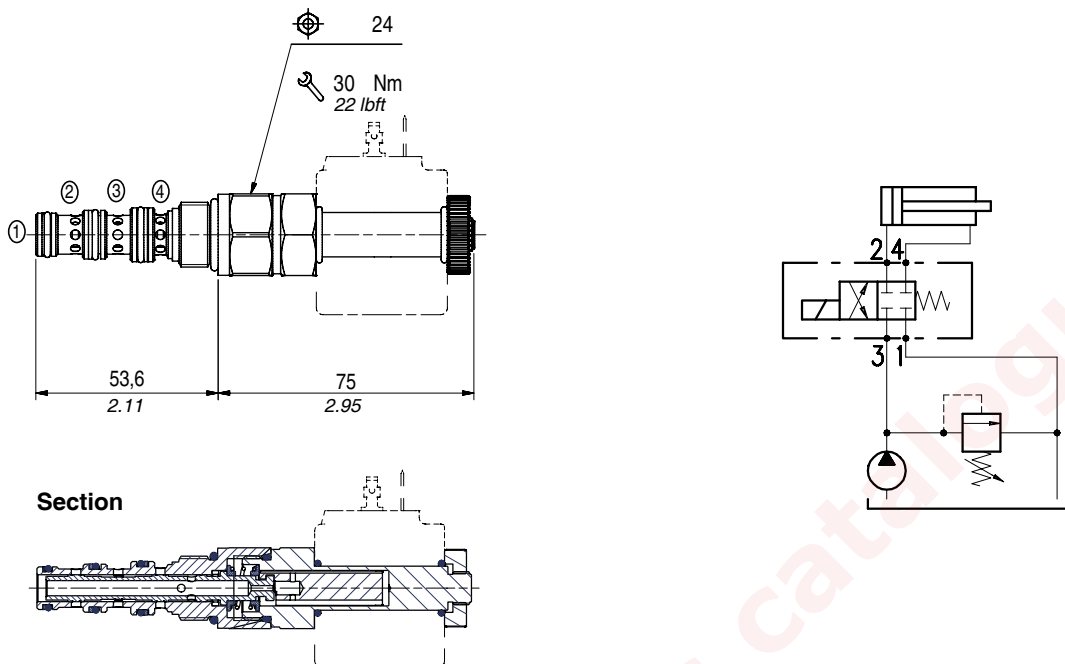

Rating diagrams

Typical pressure drop vs. flow characteristics

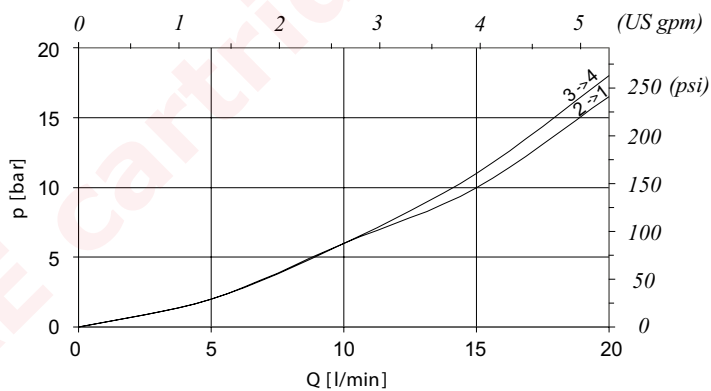

Order code

ER 08M / 50 N □

Seals

B) Buna
V) Viton

Dimensions and hydraulic circuit

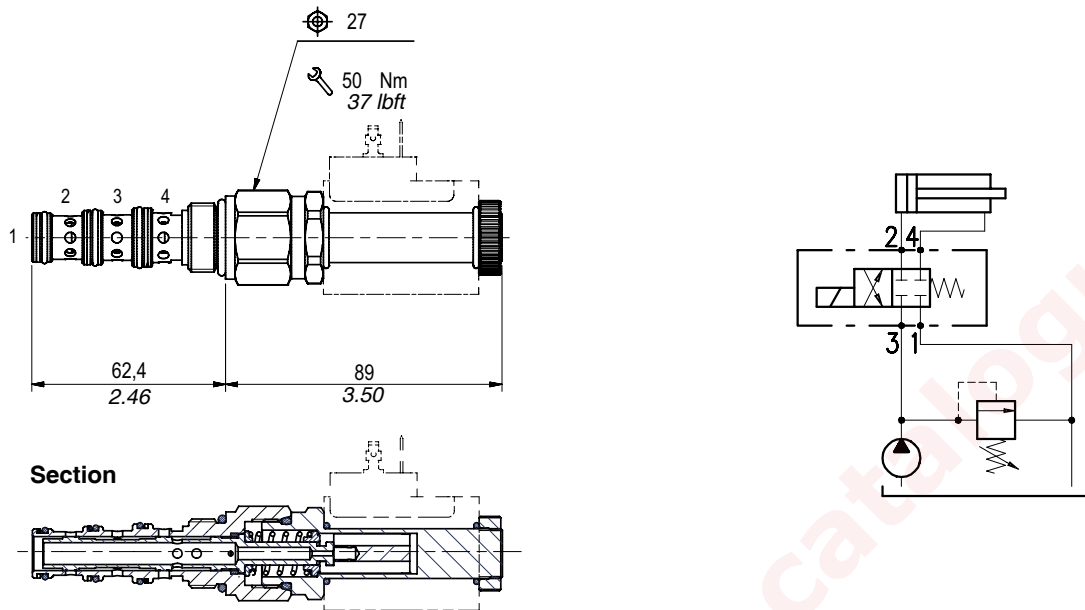

Rating diagrams

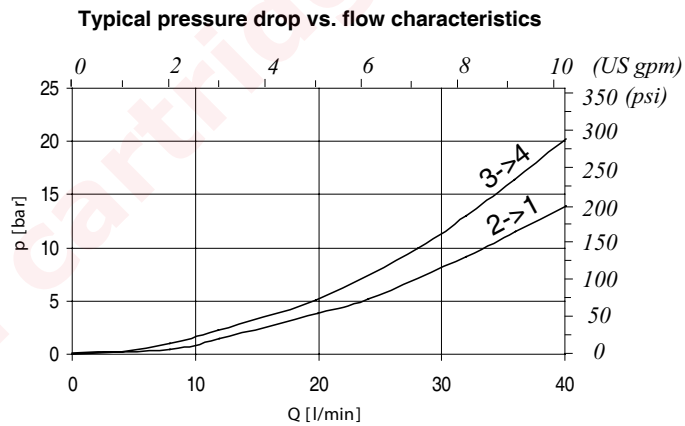

Order code

ER 10M / 50 □ □

Manual override option
(see page 163)

- N)** No emergency (standard)
- T)** Screw
- F)** Pull button

Seals

- B)** Buna
- V)** Viton

Dimensions and hydraulic circuit

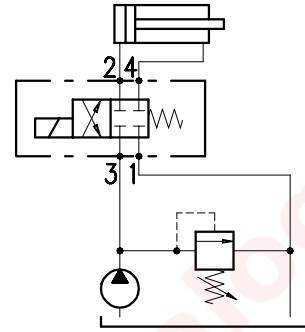
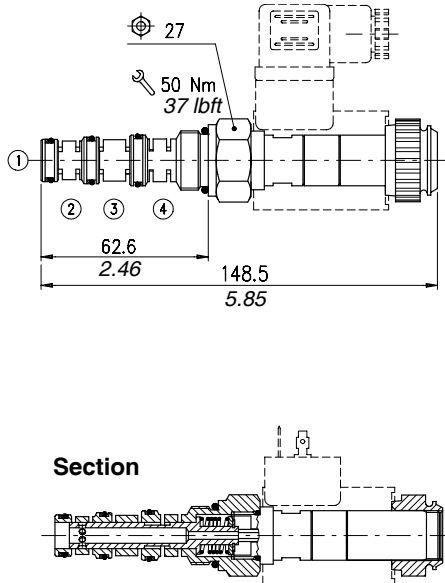

Rating diagrams

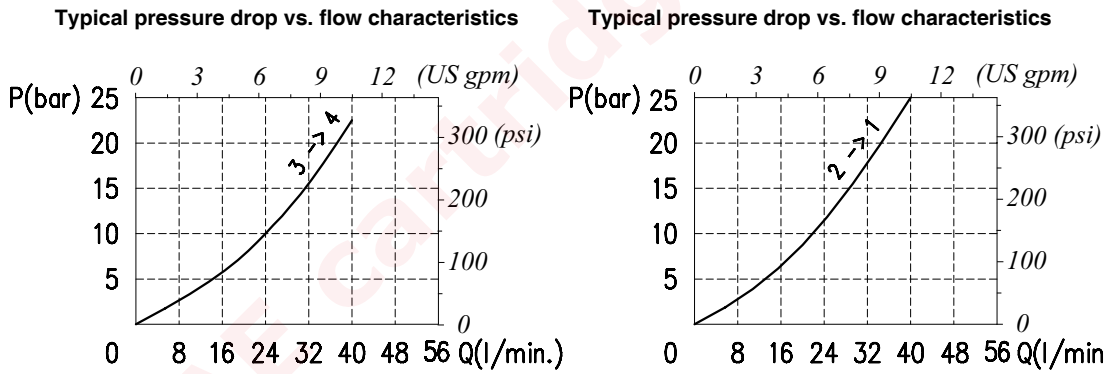

Order code

ER 10A / 50 P □

Seals

B) Buna
V) Viton

Dimensions and hydraulic circuit

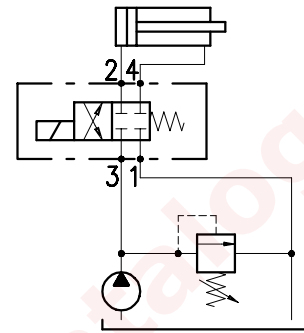
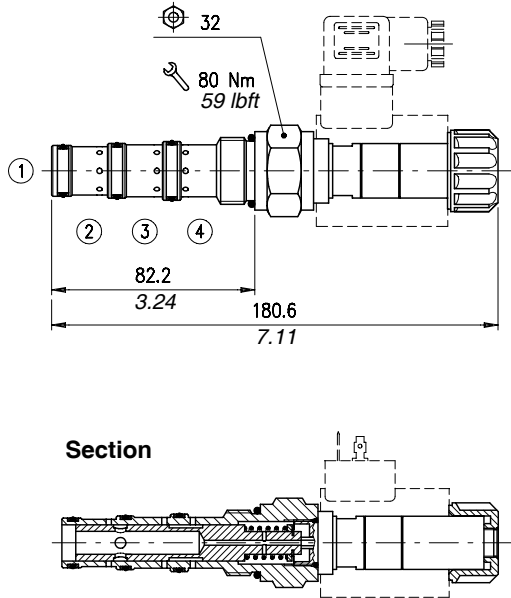

Rating diagrams

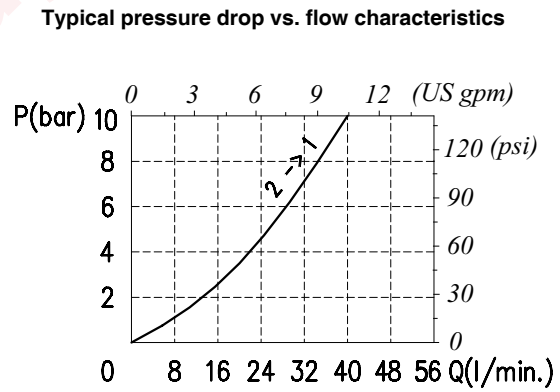
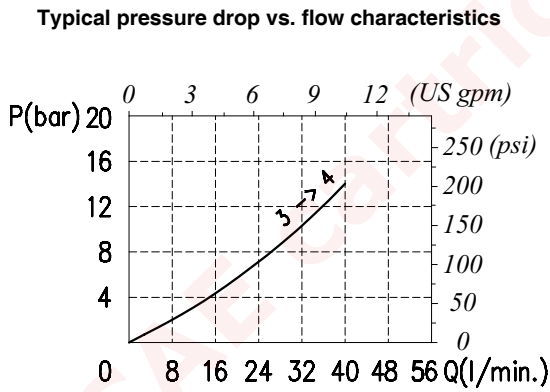

Order code

ER 12A / 50 P □

Seals

B) Buna
V) Viton



Operation

When the spool is deenergized the valve keeps all ways shut.
When the solenoid is energized the valve allows free oil flow from 3 to 4 and from 2 to 1.

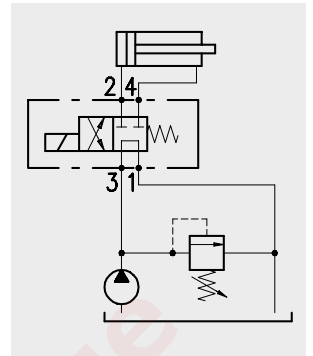

Performance

Cartridges

Type	Maximum flow		Maximum pressure		Solenoids	*Oil leaks from 1 to 2	Weight		Cavities and tools
	l/min	US gpm	bar	psi			kg	lb	
ER08M/6	18	4.7	210	3050	BE/EC 36 see page 157	40 cm ³ /min. - 2.44 in ³ /min at 210 bar - 3050 psi	0,200	0.44	see cavity SAE 8-4 page 173
ER10M/6	40	10.5			BC 16 see page 160	80 cm ³ /min. - 4.88 in ³ /min at 210 bar - 3050 psi	0,45	0.99	see cavity SAE 10-4 page 173
ER12A/6	40	10.5			BIN 22 see page 169	45 cm ³ /min. - 2.75 in ³ /min at 210 bar - 3050 psi	0,490	1.08	see cavity SAE 12-4 page 173

*with oil viscosity of 46 cst

Dimensions and hydraulic circuit

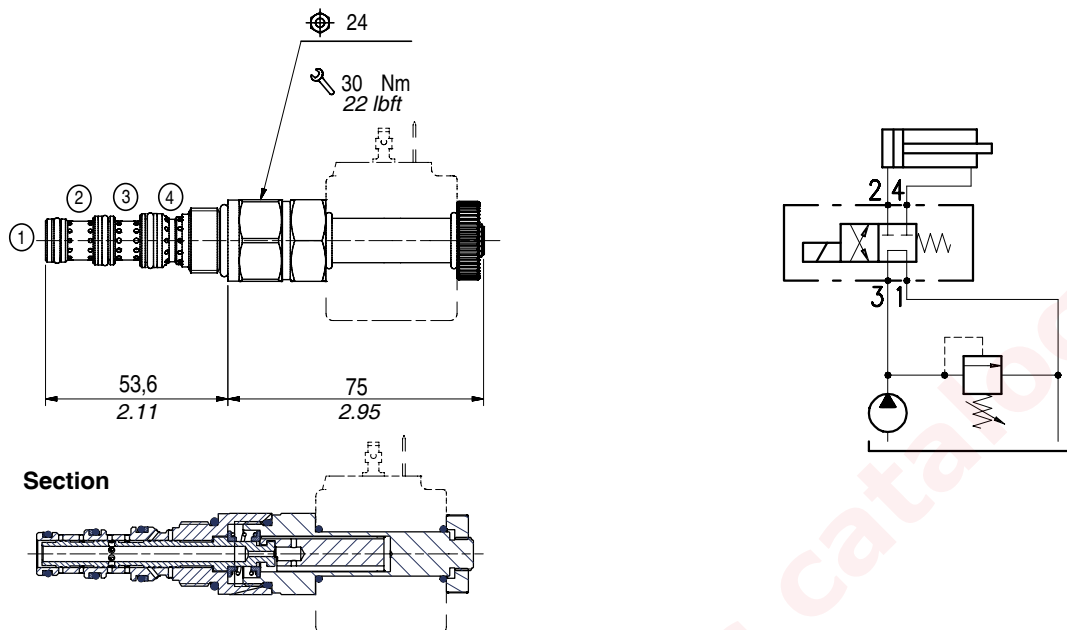

Rating diagrams

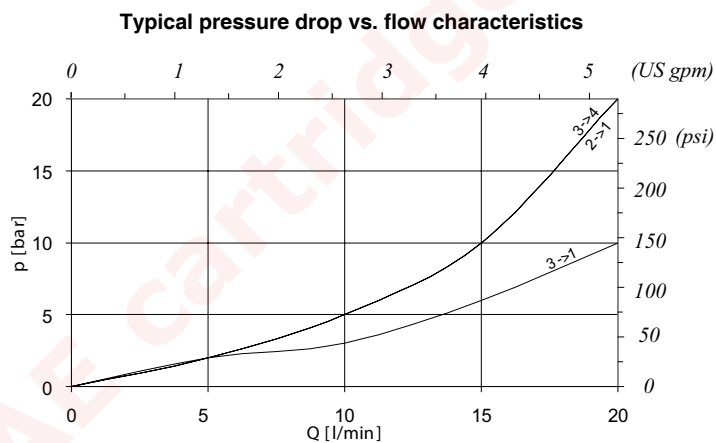

Order code

ER 08M / 60 N □

Seals

B) Buna
V) Viton

Dimensions and hydraulic circuit

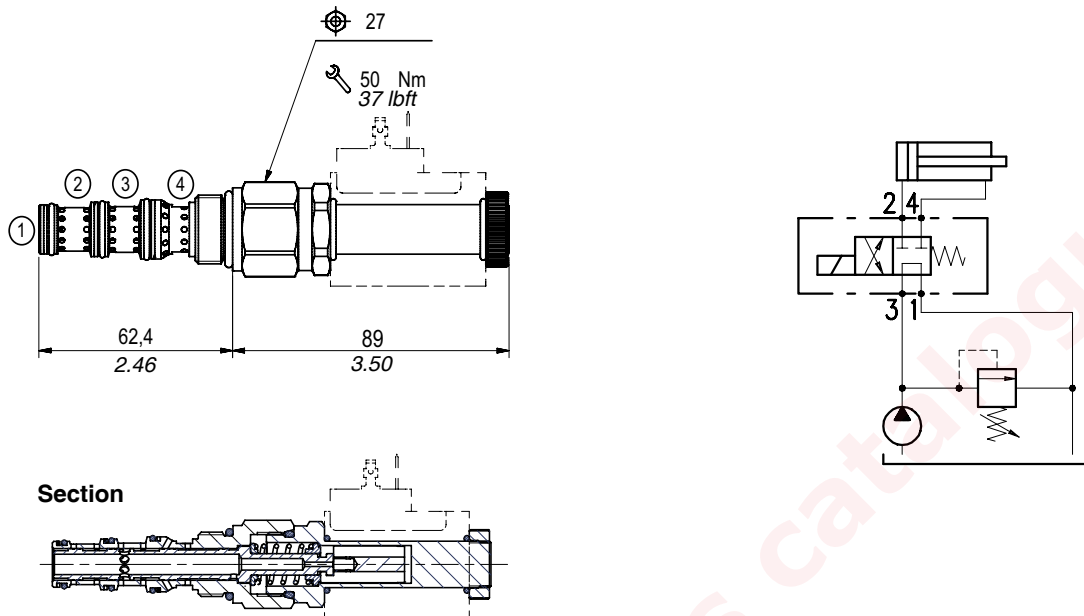

Rating diagrams

Typical pressure drop vs. flow characteristics

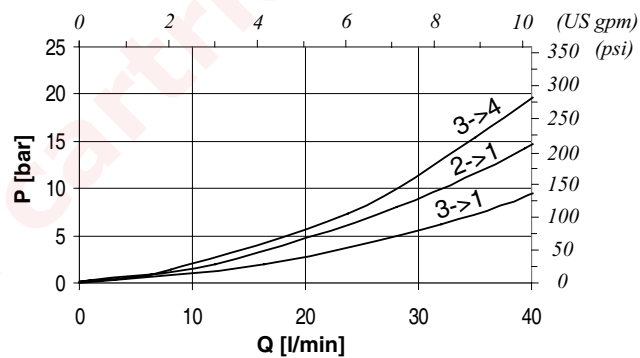

Order code

ER 10M / 60 □ □

Manual override option

(see page 163)

- N) No emergency (standard)
- T) Screw
- F) Pull button

Seals

- B) Buna
- V) Viton

Dimensions and hydraulic circuit

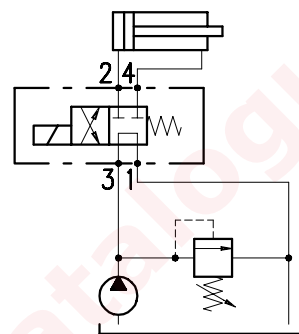
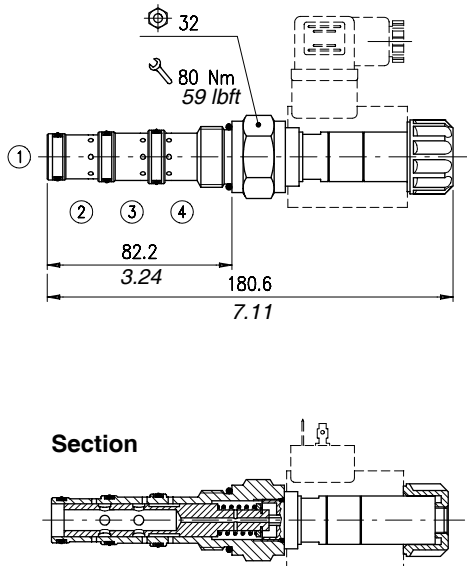

Rating diagrams

Typical pressure drop vs. flow characteristics

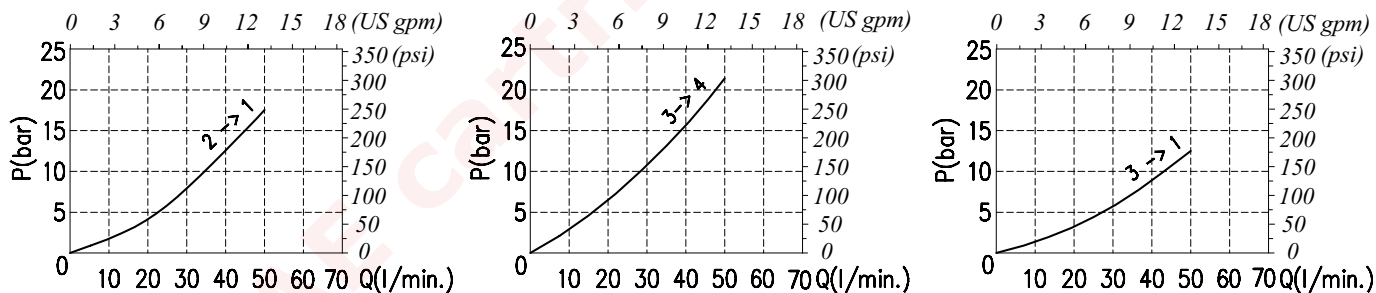

Order code

ER 12A / 60 P □

Seals

B) Buna
V) Viton

Operation

When the solenoid is deenergized the valve allows free oil flow of the ways 1,2 and 4 while the way in 3 is kept shut.
When the solenoid is energized the valve allows free oil flow from 3 to 4 and from 2 to 1.

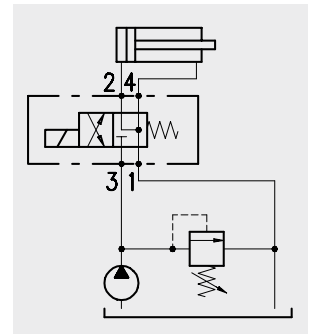

Performance

Cartridges

Type	Maximum flow		Maximum pressure		Solenoids	*Oil leaks from 1 to 2	Weight		Cavities and tools
	l/min	US gpm	bar	psi			kg	lb	
ER08M/7	18	4.7	210	3050	BE/EC 36 see page 157	40 cm ³ /min. - 2.44 in ³ /min at 210 bar - 3050 psi	0,200	0.44	see cavity SAE 8-4 page 173
ER10M/7	40	10.5			BC 16 see page 160	80 cm ³ /min. - 4.88 in ³ /min at 210 bar - 3050 psi	0,45	0.99	see cavity SAE 10-4 page 173
ER12A/7	40	10.5			BIN 22 see page 159	200 cm ³ /min. - 12.2 in ³ /min at 210 bar - 3050 psi	0,490	1.08	see cavity SAE 12-4 page 173

*with oil viscosity of 46 cst

Dimensions and hydraulic circuit

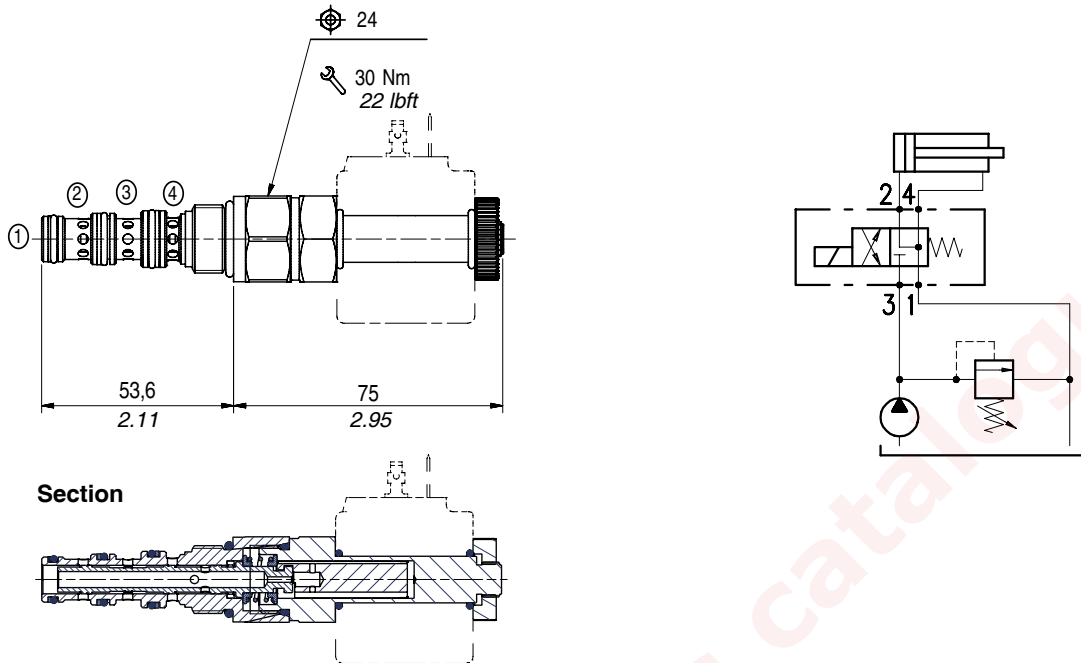

Rating diagrams

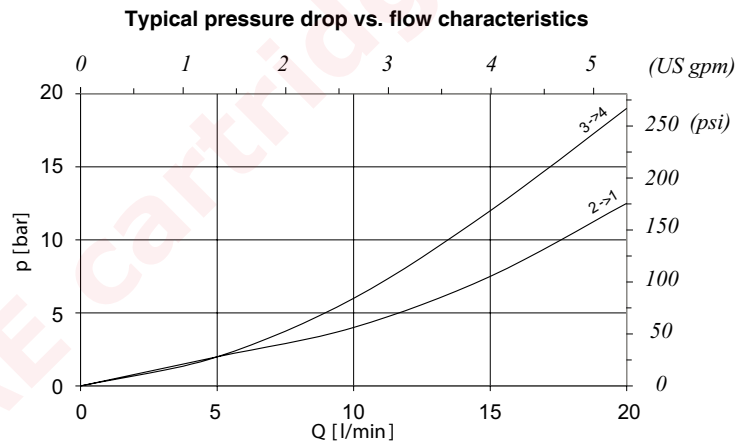

Order code

ER 08M / 70 N □

Seals

B) Buna
V) Viton

Dimensions and hydraulic circuit

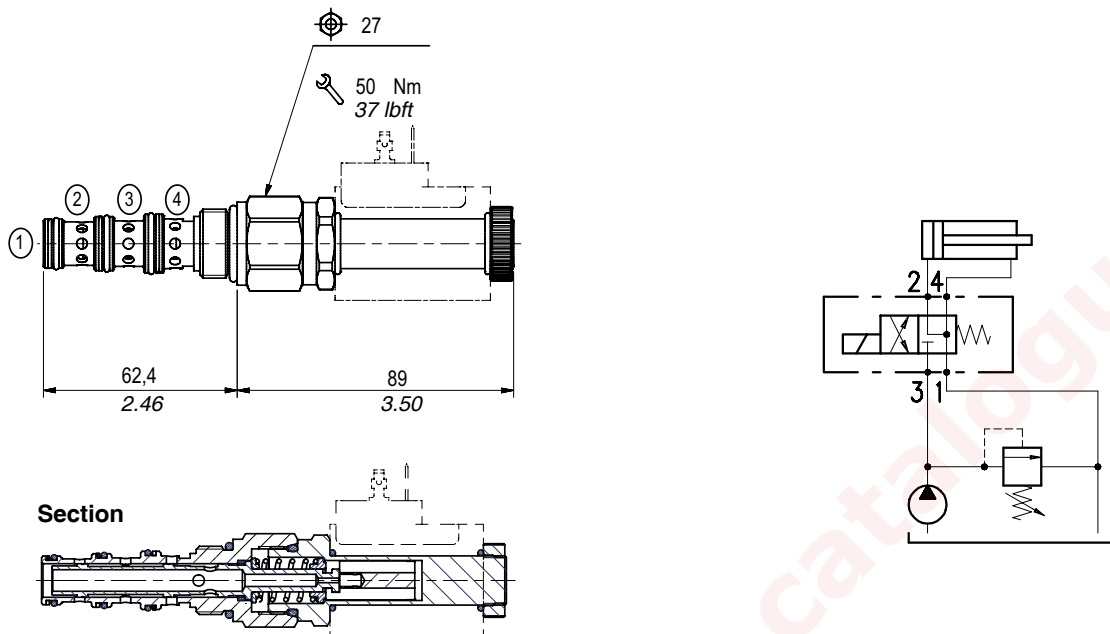

Rating diagrams

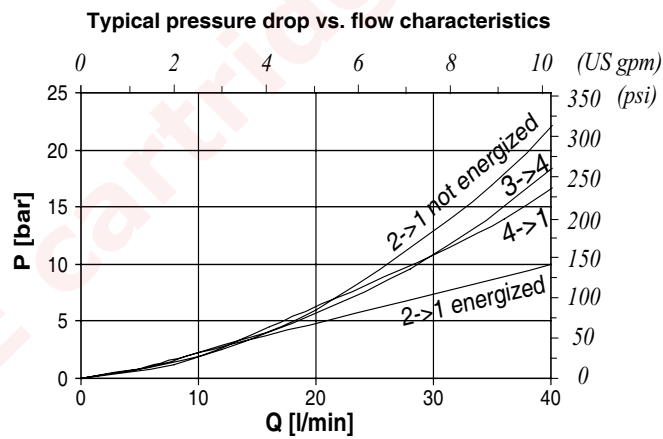

Order code

ER 10M / 70 □ □

Manual override option

- N)** No emergency (standard)
- T)** Screw
- F)** Pull button

Seals

(see page 163)

- B)** Buna
- V)** Viton

Dimensions and hydraulic circuit

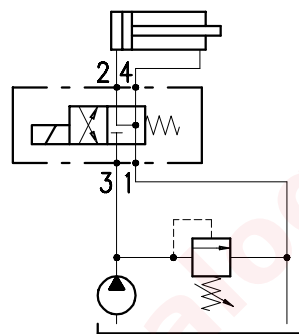
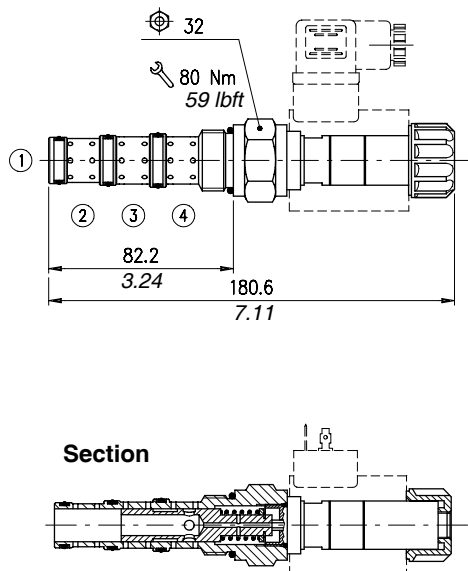

Rating diagrams

Typical pressure drop vs. flow characteristics

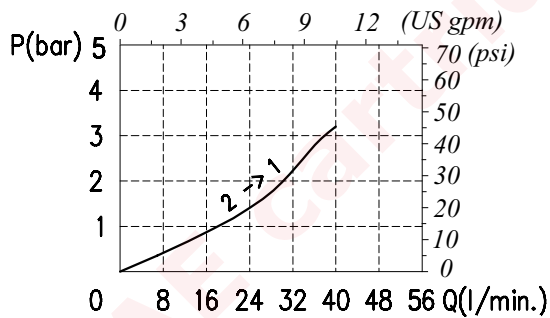

Typical pressure drop vs. flow characteristics

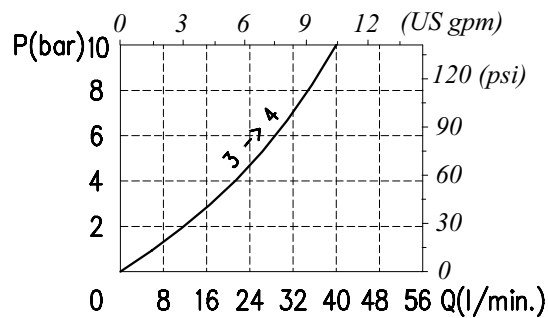

Order code

ER 12A / 70 P □

Seals

B) Buna
V) Viton

Operation

When the solenoid is deenergized the valve allows free oil flow from 3 to 4 and 2 to 1.
when the solenoid is energized the valve allows free oil flow from 3 to 2 and from 4 to 1.

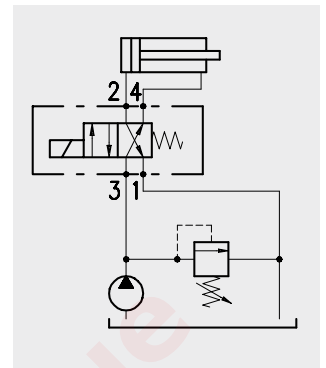

Performance

Cartridges

Type	Maximum flow		Maximum pressure		Solenoids	*Oil leaks from 1 to 2	Weight		Cavities and tools
	l/min	US gpm	bar	psi			kg	lb	
ER08M/8	15	4	210	3050	BE/EC 36 see page 157	40 cm ³ /min. - 2.44 in ³ /min at 210 bar - 3050 psi	0,200	0.44	see cavity SAE 8-4 page 173
ER10M/8	35	9.2			BC 16 see page 160	80 cm ³ /min. - 4.88 in ³ /min at 210 bar - 3050 psi	0,45	0.99	see cavity SAE 10-4 page 173
ER12A/8	40	10.5			BIN 22 see page 159	200 cc/min. - 12.2 in ³ /min at 210 bar - 3050 psi	0,490	1.08	see cavity SAE 12-4 page 173

*With oil viscosity of 46 cst

Dimensions and hydraulic circuit

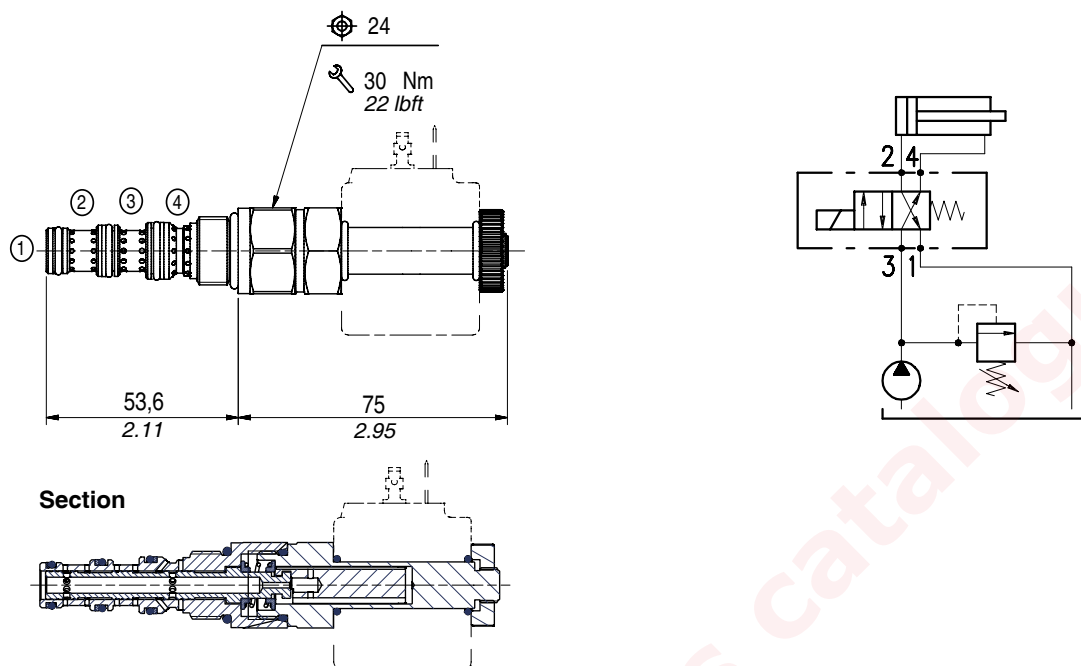

Rating diagrams

Typical pressure drop vs. flow characteristics

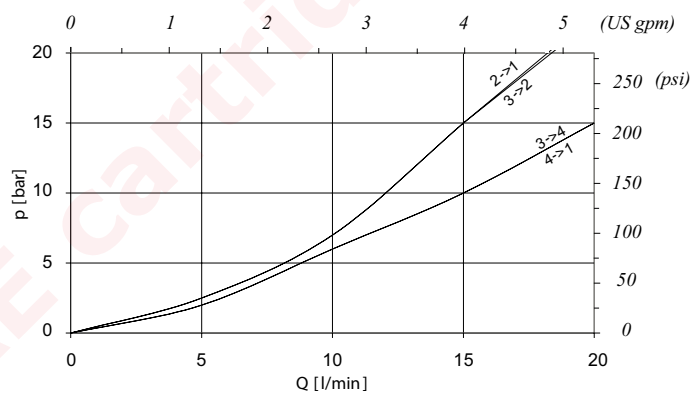

Order code

ER 08M / 80 N □

Seals

B) Buna
V) Viton

Dimensions and hydraulic circuit

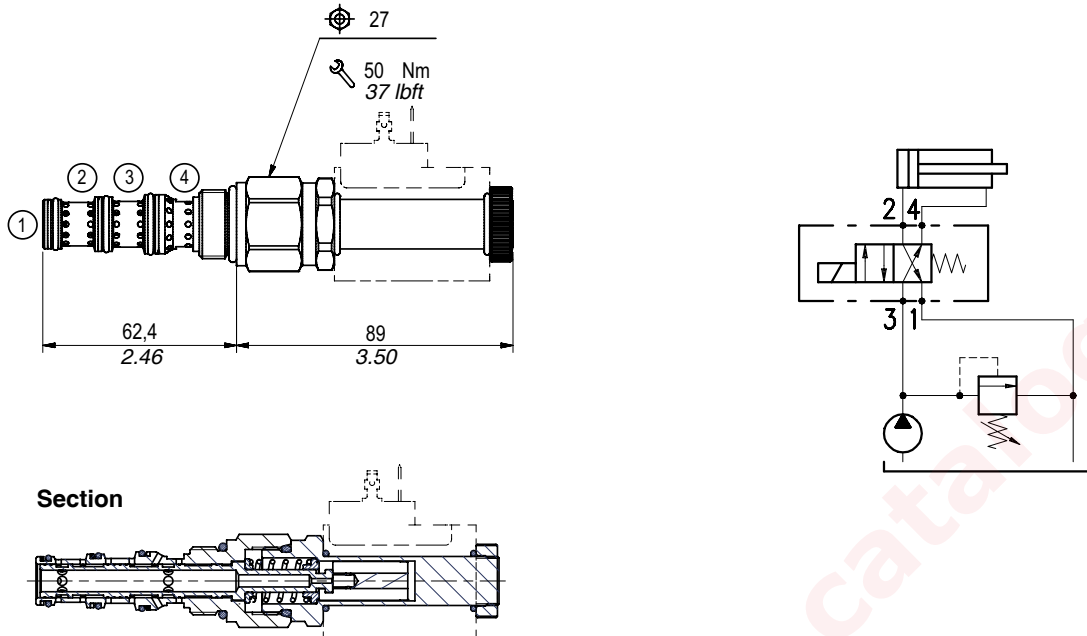

Rating diagrams

Typical pressure drop vs. flow characteristics

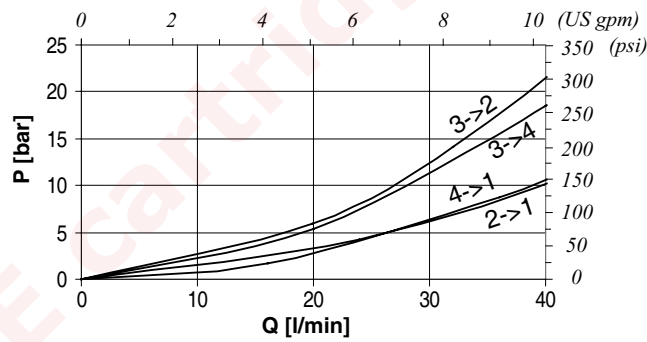

Order code

ER 10M / 80 □ □

Manual override option
(see page 163)

- N)** No emergency (standard)
- T)** Screw
- F)** Pull button

Seals

- B)** Buna
- V)** Viton

Dimensions and hydraulic circuit

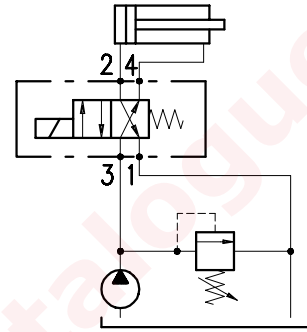
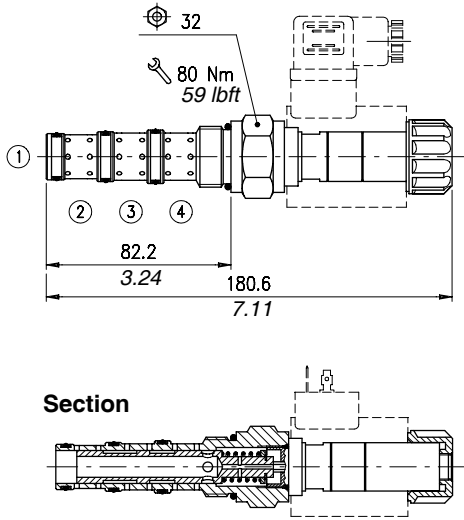

Rating diagrams

Typical pressure drop vs. flow characteristics

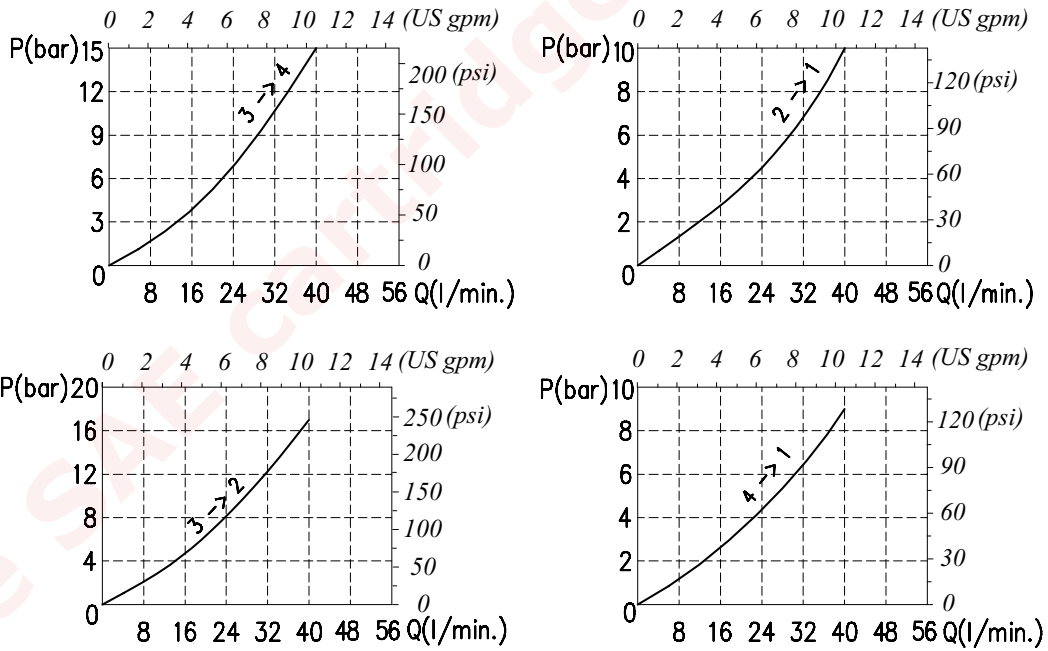

Order code

ER 12A / 80 P □

Seals

B) Buna
V) Viton

Operation

When the spool is deenergized the valve keeps all ways shut.
When the solenoid is energized the valve allows free oil flow from 3 to 4 and from 2 to 1.

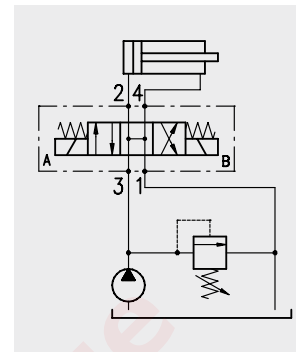

Performance

Cartridges

Type	Maximum flow		Maximum pressure		Solenoids	*Oil leaks from 1 to 2	Weight		Cavities and tools
	l/min	US gpm	bar	psi			kg	lb	
ET08M/1	18	4.7	210	3050	BE/EC 36 see page 157	40 cm ³ /min. - 2.44 in ³ /min at 210 bar - 3050 psi	0,250	0.55	see cavity SAE 8-4 page 173
ET10A/1	30	8			BIN 19 see page 158	120 cm ³ /min. - 7.32 in ³ /min at 210 bar - 3050 psi	0,310	0.68	see cavity SAE 10-4 page 173
ET12A/1	40	10.5			BIN 22 see page 159	300 cm ³ /min. - 18.31 in ³ /min at 210 bar - 3050 psi	0,720	1.59	see cavity SAE 12-4 page 173
ET16A/1	90	24			BIN 22 see page 159	100 cm ³ /min. - 6.10 in ³ /min at 210 bar - 3050 psi	0,920	2.03	see cavity SAE 16-4 page 173
ET10B/1	20	5.3			BC 16 see page 160	25 cm ³ /min. - 1.52 in ³ /min at 210 bar - 3050 psi	0,300	0.66	see cavity SAE 10-4 page 173
ET10M/1	40	10.5			BC 16 see page 160	80 cm ³ /min. - 4.88 in ³ /min at 210 bar - 3050 psi	0,500	1.10	

*with oil viscosity of 46 cst

Dimensions and hydraulic circuit

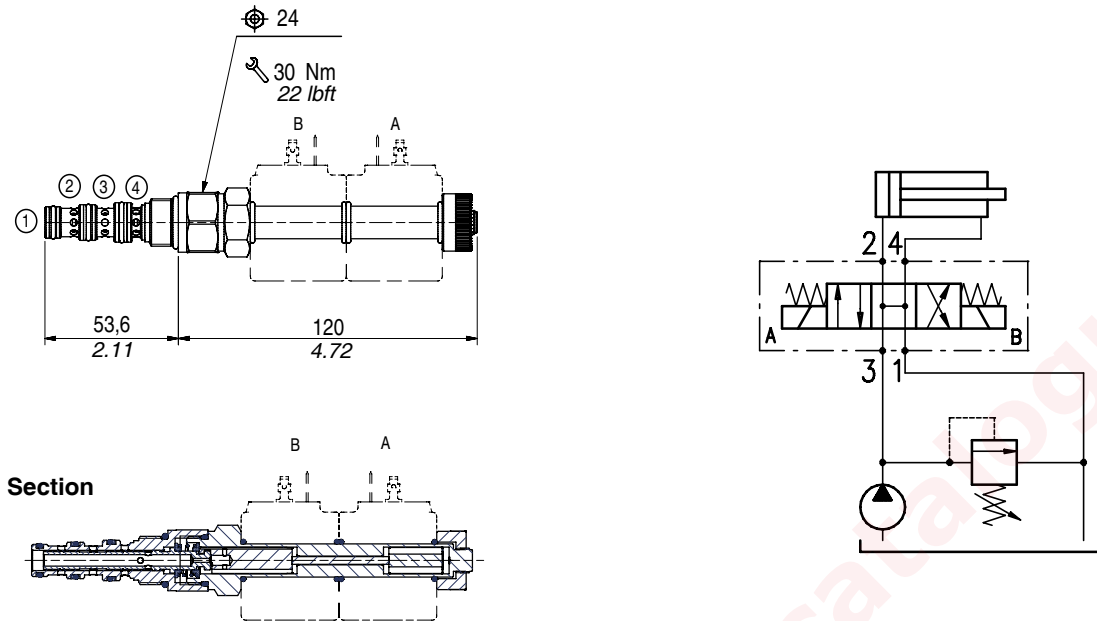

Rating diagrams

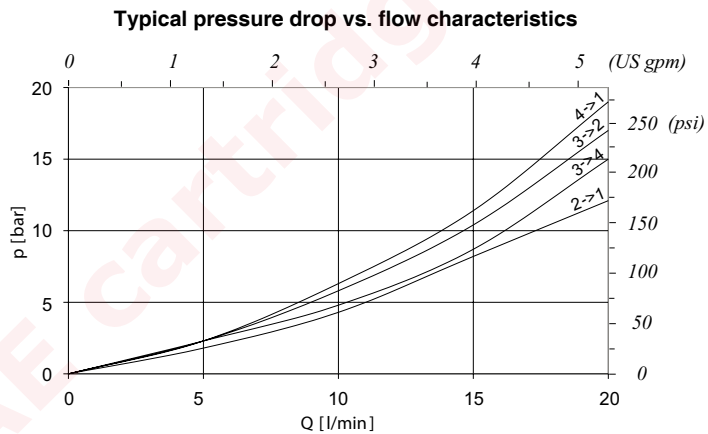

Order code

ET 08M / 10 □ - □

Manual override option
(see page 163)

N) No emergency (standard)
D) Button

Seals

B) Buna
V) Viton

Dimensions and hydraulic circuit

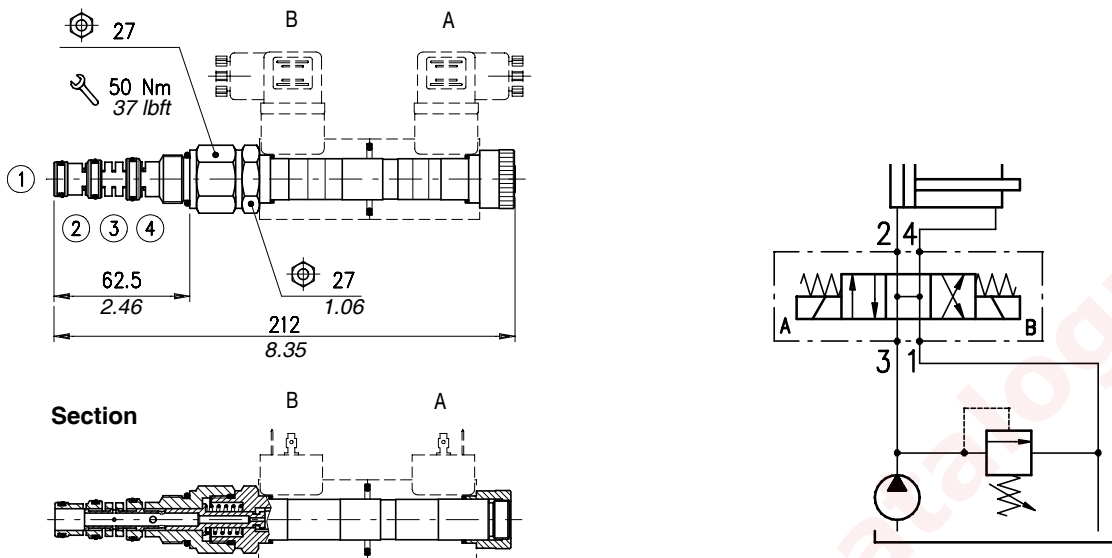

Typical pressure drop vs. flow characteristics

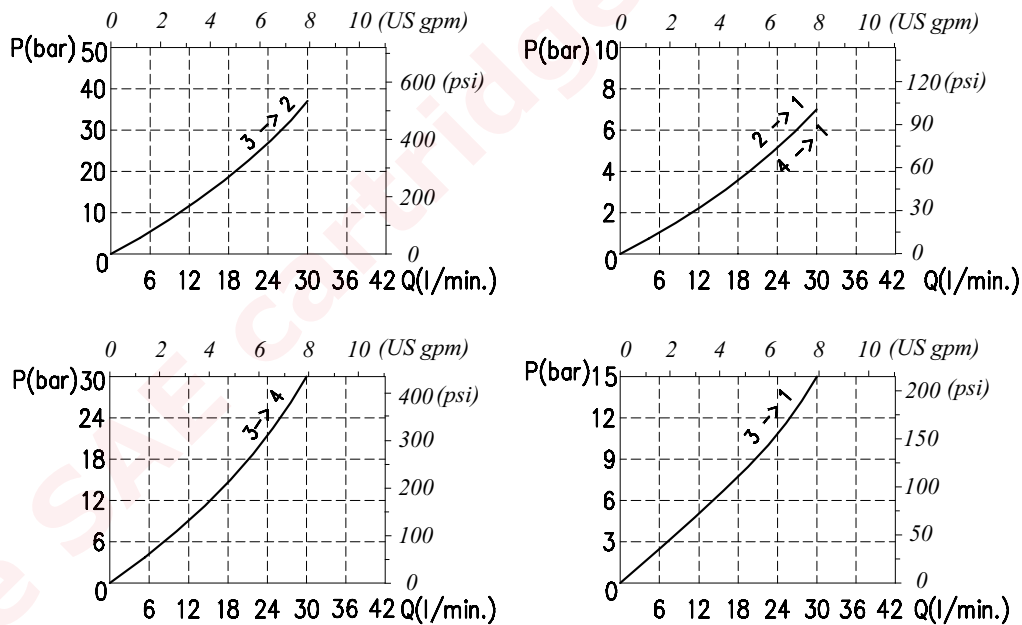

Order code

ET 10A / 10 □ - □

Manual override option
(see page 163)

N) No emergency (standard)
P) Button

Seals

B) Buna
V) Viton

Dimensions and hydraulic circuit

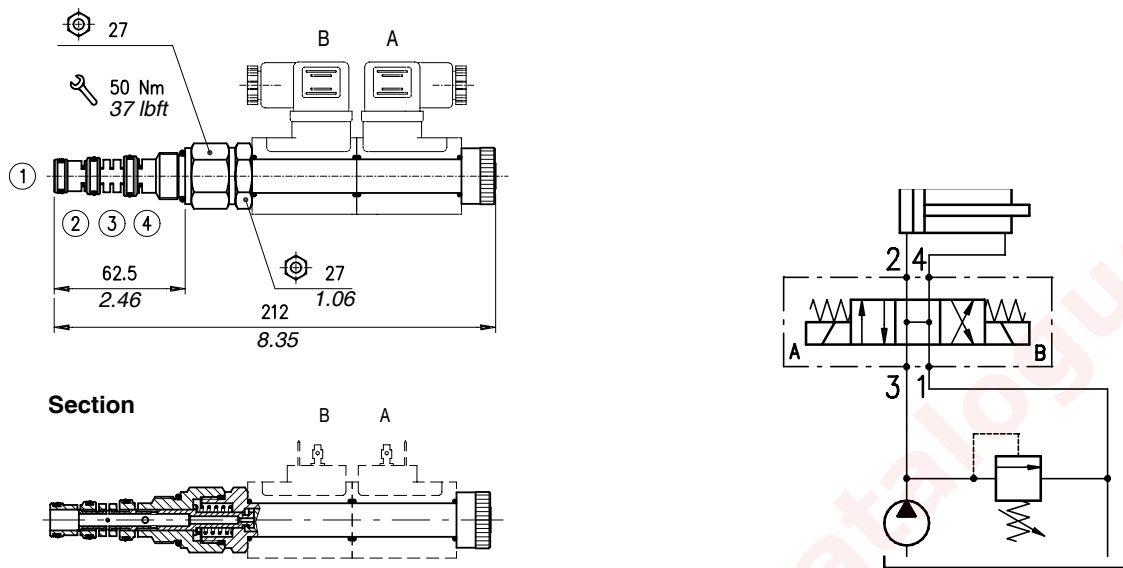

Rating diagrams

Typical pressure drop vs. flow characteristics

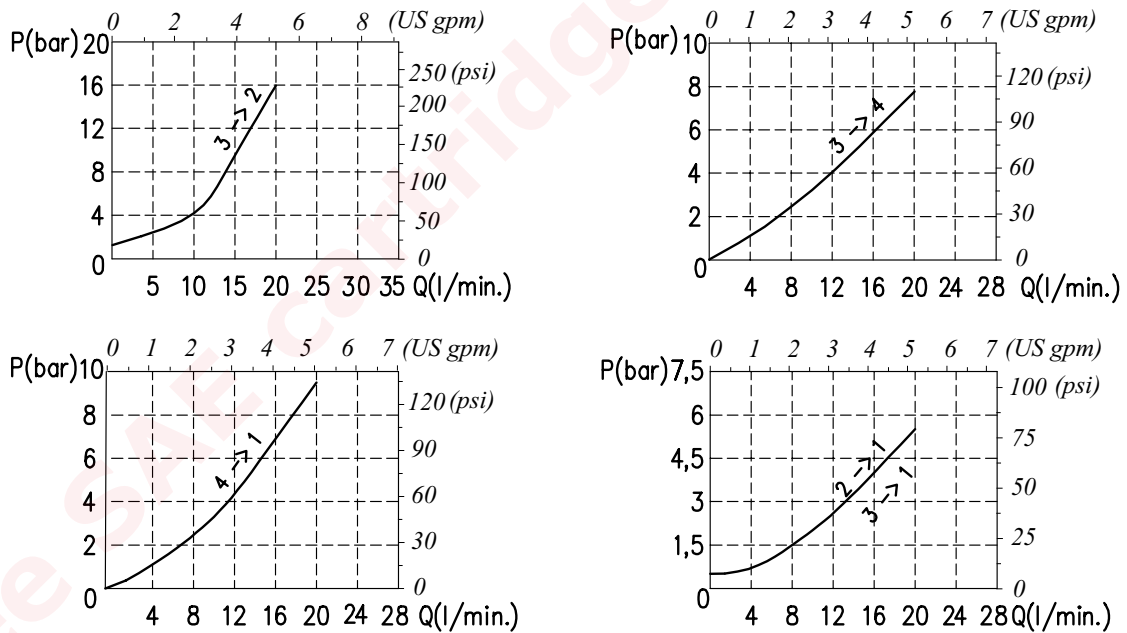

Order code

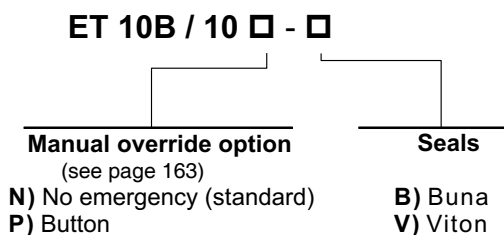

Dimensions and hydraulic circuit

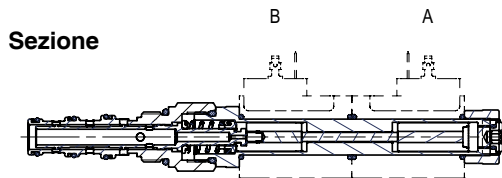
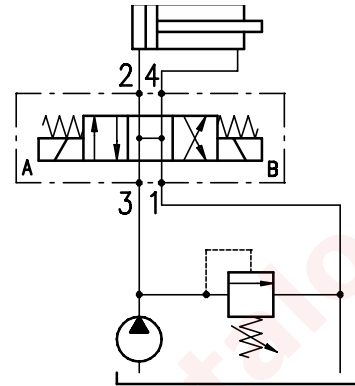
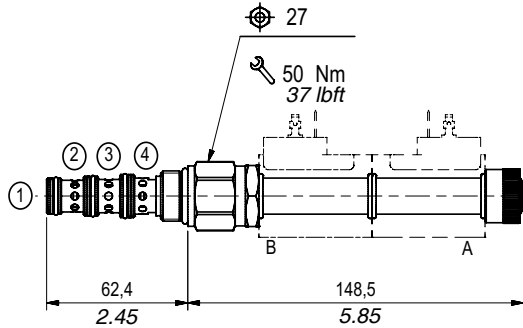

Rating diagrams

Typical pressure drop vs. flow characteristics

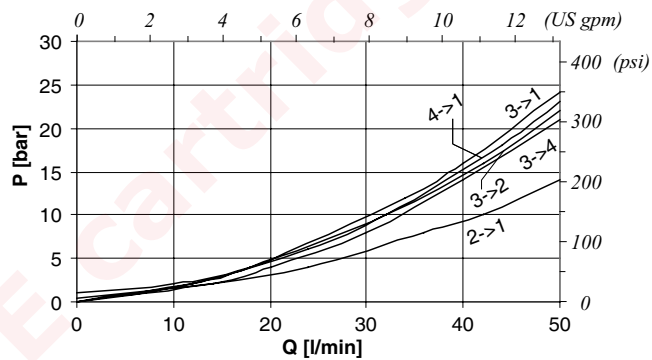

Order code

ET 10M / 10 □ - □

Manual override option
(see page 163)

- N)** No emergency (standard)
- D)** Push-pull with mechanical detent
- P)** Button
- E)** Push-pull with spring detent

Seals

- B)** Buna
- V)** Viton

Dimensions and hydraulic circuit

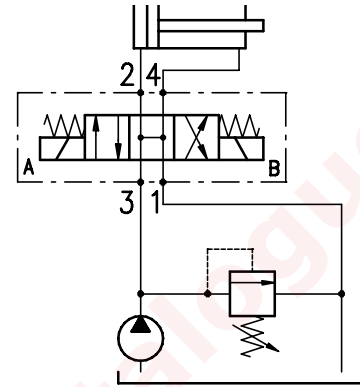
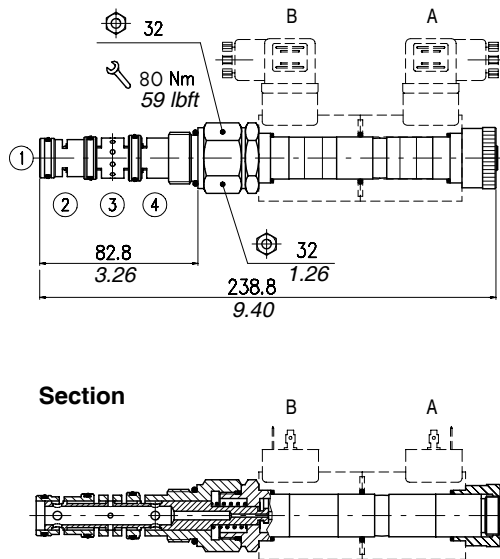

Rating diagrams

Typical pressure drop vs. flow characteristics

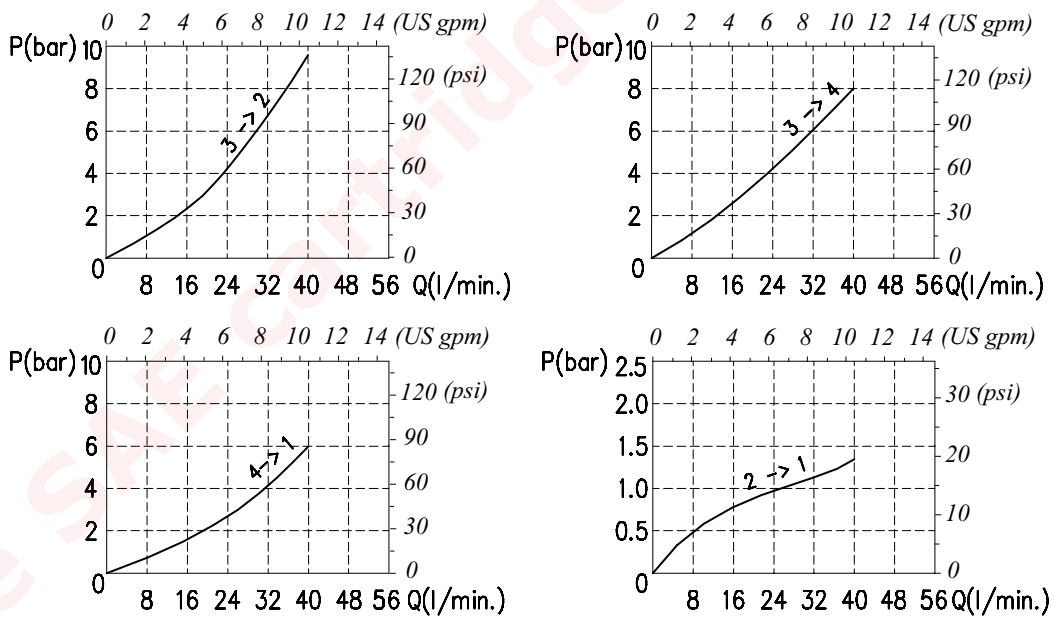

Order code

ET 12A / 10 □ - □

Manual override option
(see page 163)

N) No emergency (standard)
P) Button

Seals

B) Buna
V) Viton

Dimensions and hydraulic circuit

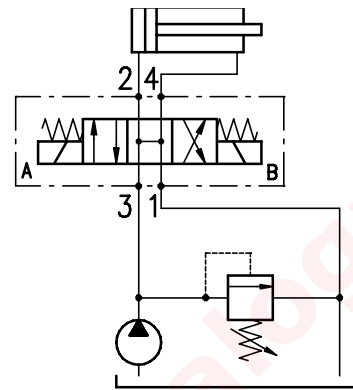
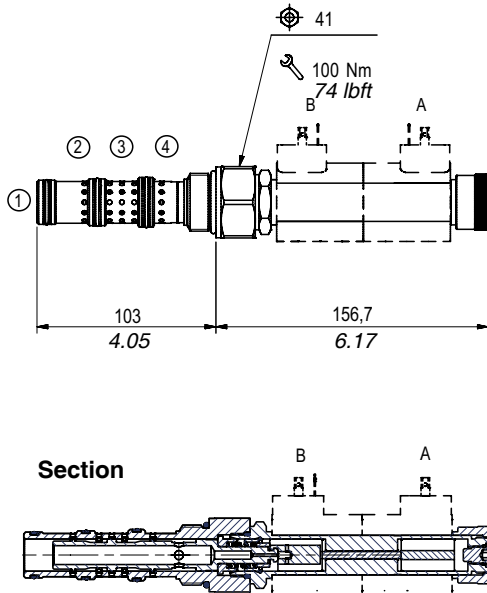

Rating diagrams

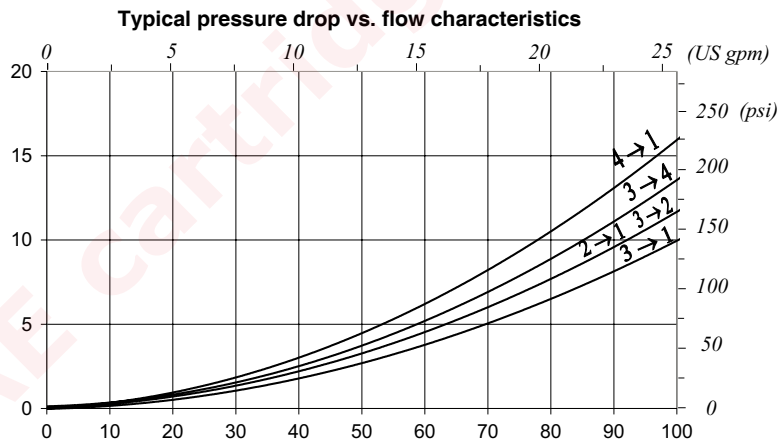

Order code

ET 16A / 10 □ - □

Manual override option
(see page 163)

N) No emergency (standard)
P) Button

Seals

B) Buna
V) Viton



Operation

When the solenoid is deenergized the valve is with all the ways (1,2,3,4) closed.
When the solenoids are alternatively energized the valve provides for free oil flow from either 3 to 2 and 4 to 1 or from 3 to 4 and 2 to 1.

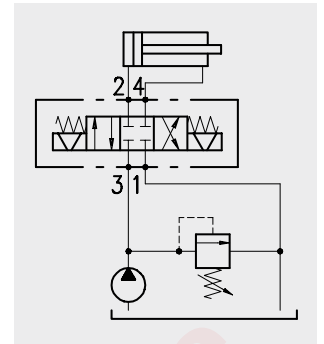

Performance

Cartridges

Type	Maximum flow		Maximum pressure		Solenoids	*Oil leaks from 1 to 2	Weight		Cavities and tools
	l/min	US gpm	bar	psi			kg	lb	
ET08C/2	8	2.1	210	3050	BE/EC 36 see page 157	40 cm ³ /min. - 2.44 in ³ /min at 210 bar - 3050 psi	0,320	0.70	See cavity SAE 8-4 page 173
ET08F/2	10	2.6			BC 16 see page 160	10 cm ³ /min. - 0.61 in ³ /min at 210 bar - 3050 psi	0,320	0.70	
ET08M/2	18	4.7			BE/EC 36 see page 157	40 cm ³ /min. - 2.44 in ³ /min at 210 bar - 3050 psi	0,250	0.55	
ET10M/2	40	10.5			BC 16 see page 160	80 cm ³ /min. - 4.88 in ³ /min at 210 bar - 3050 psi	0,50	1.10	See cavity SAE 10-4 page 173
ET10A/2	30	8			BIN 19 see page 158	120 cm ³ /min. - 7.32 in ³ /min at 210 bar - 3050 psi	0,310	0.68	
ET12A/2	40	10.5			BIN 22 see page 159	60 cm ³ /min. - 3.66 in ³ /min at 210 bar - 3050 psi	0,720	1.59	See cavity SAE 12-4 page 173
ET16A/2	75	20			BIN 22 see page 159	100 cm ³ /min. - 6.1 in ³ /min at 210 bar - 3050 psi	0,92	2.03	See cavity SAE 16-4 page 173
ET10B/2	20	5.3			BC 16 see page 10	20 cm ³ /min. - 1.22 in ³ /min at 210 bar - 3050 psi	0,300	0.66	See cavity SAE 10-4 page 173

*with oil viscosity of 46 cst

Dimensions and hydraulic circuit

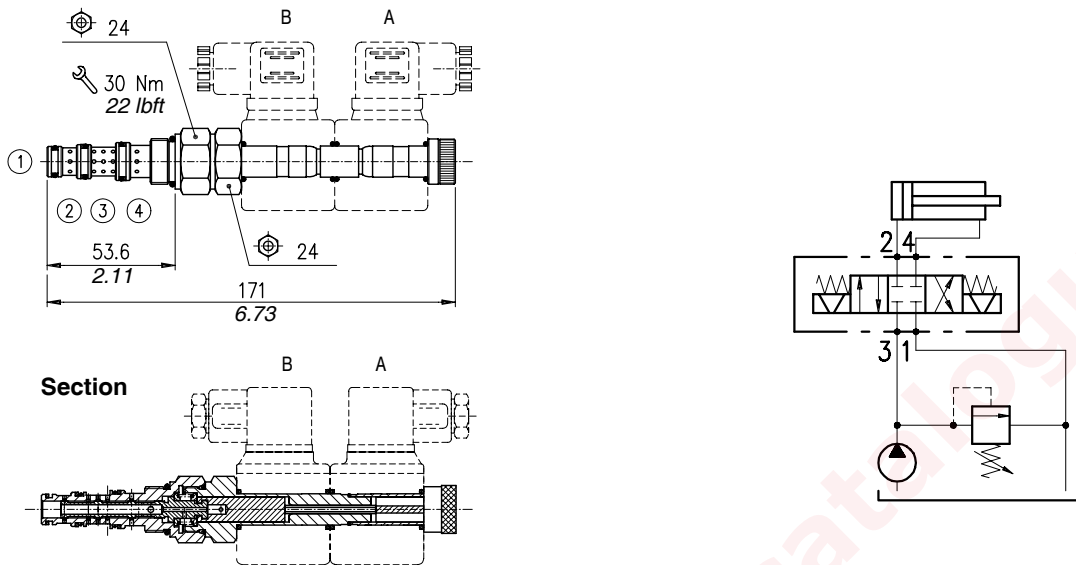

Rating diagrams

Typical pressure drop vs. flow characteristics

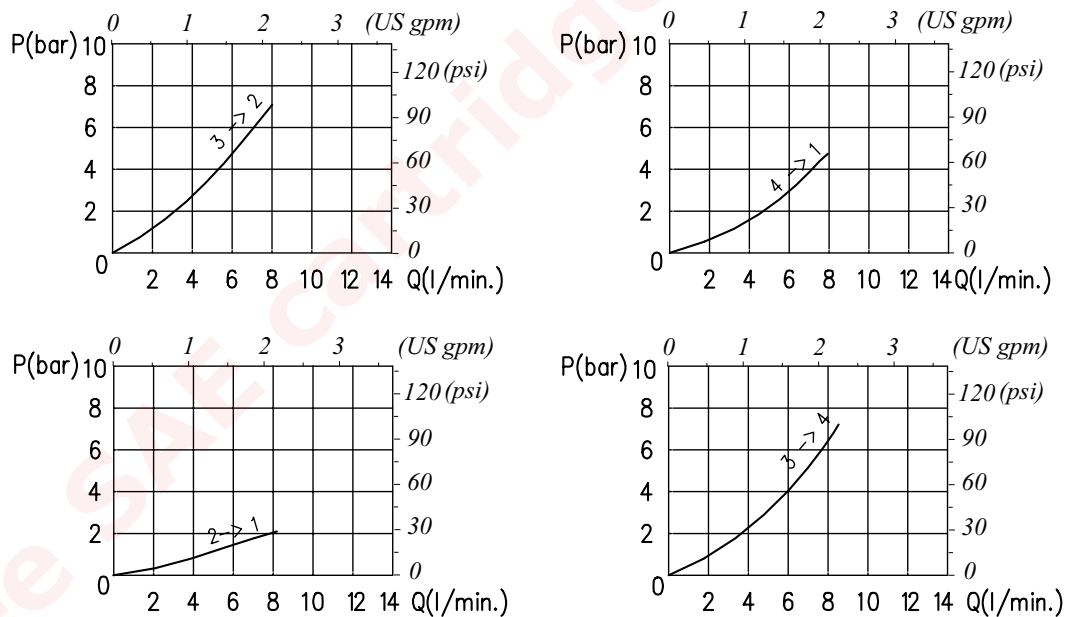

Order code

ET 08C / 20 N □

Seals

B) Buna
V) Viton

Dimensions and hydraulic circuit

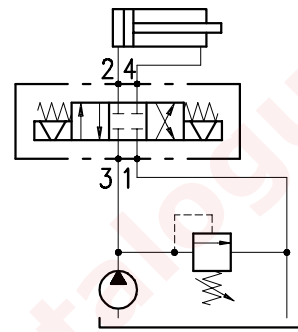
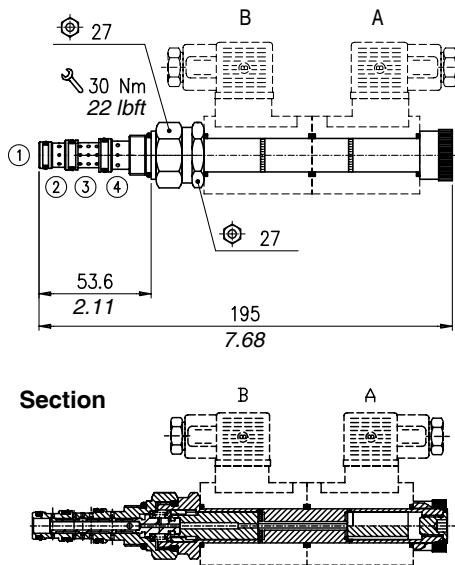

Typical pressure drop vs. flow characteristics

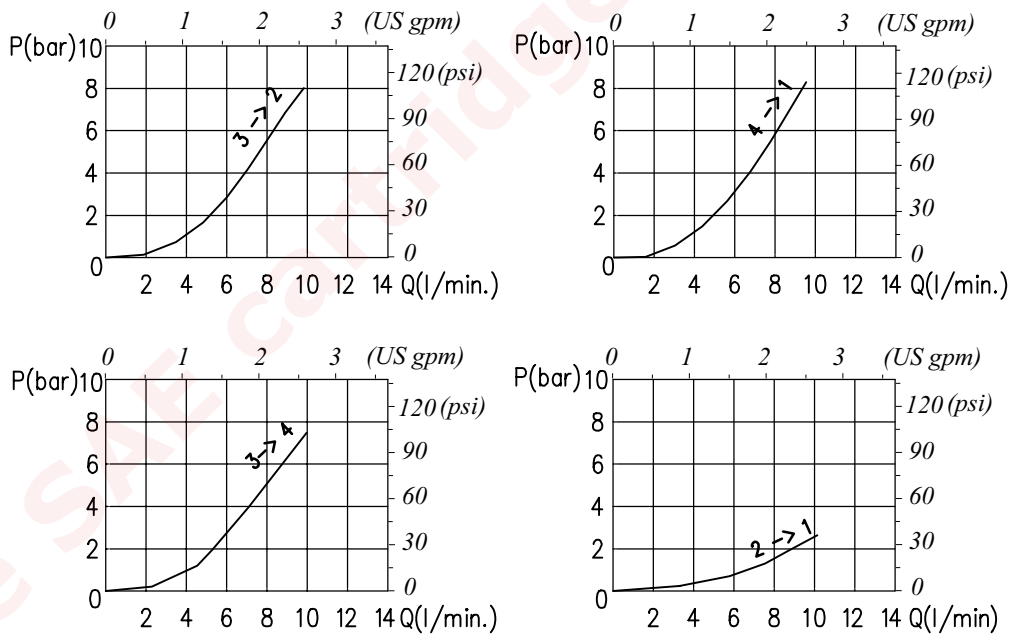

Order code

ET 08F / 20 N □

Seals

**B) Buna
V) Viton**

Dimensions and hydraulic circuit

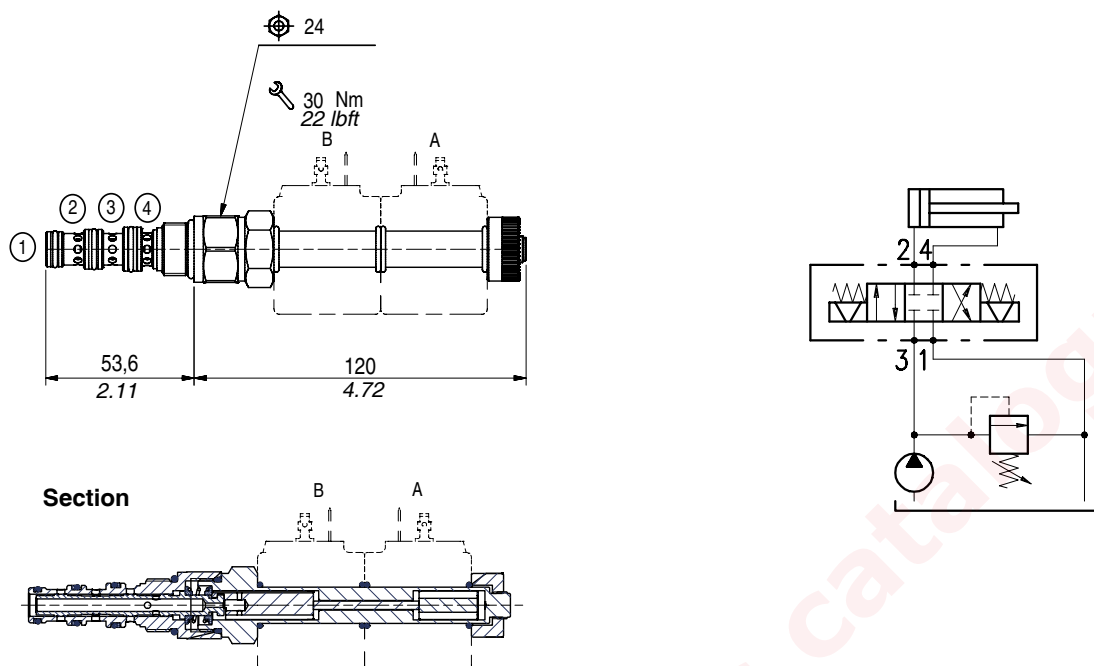

Rating diagrams

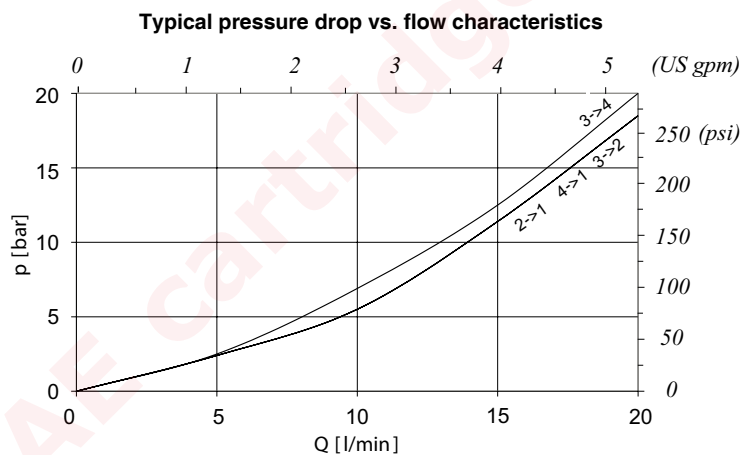

Order code

ET 08M / 20 □ - □

Manual override option
(see page 163)

N) No emergency (standard)
D) Push-pull with mechanical detent

Seals

B) Buna
V) Viton

Dimensions and hydraulic circuit

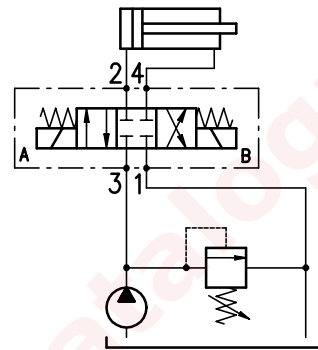
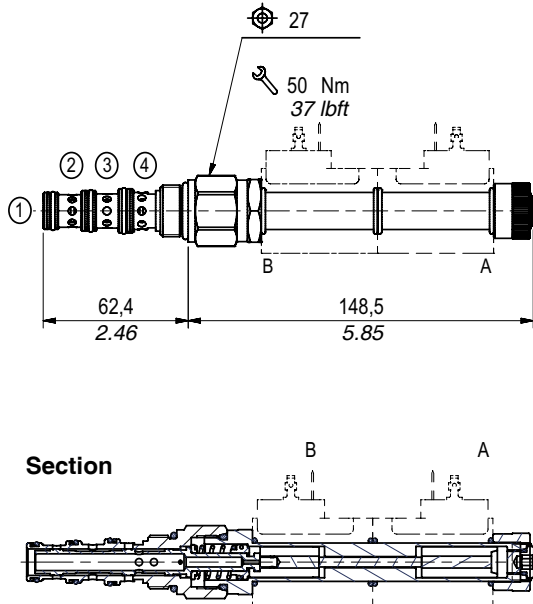

Rating diagrams

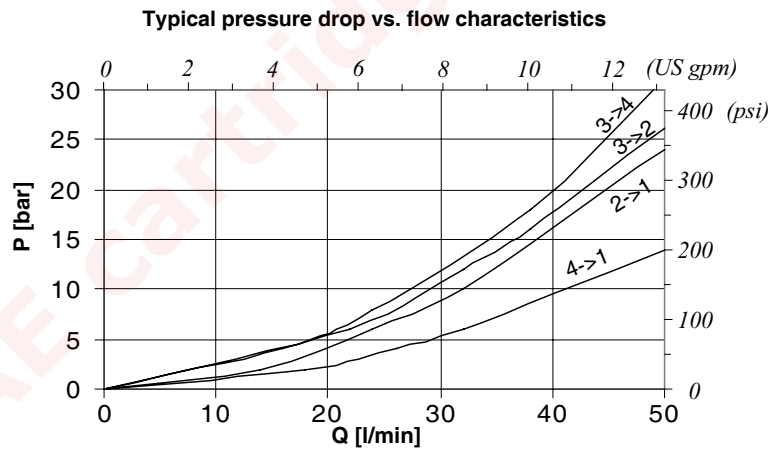

Order code

ET 10M / 20 □ - □

Manual override option

- (see page 163)
- N)** No emergency (standard)
- D)** Push-pull with mechanical detent
- P)** Button
- E)** Push-pull with spring detent

Seals

- B)** Buna
- V)** Viton

Dimensions and hydraulic circuit

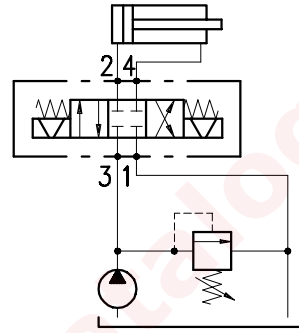
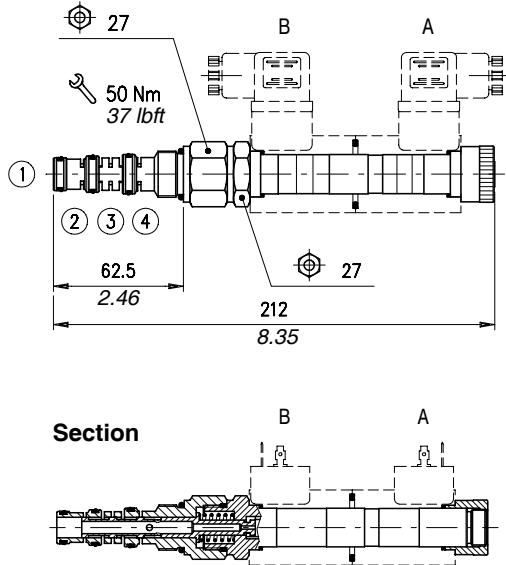

Rating diagrams

Typical pressure drop vs. flow characteristics

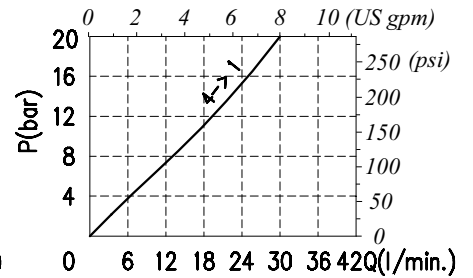
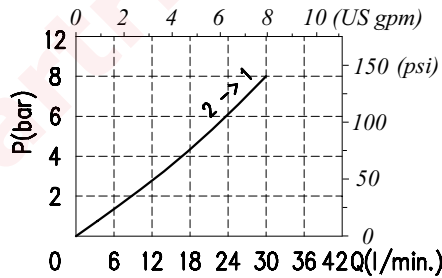
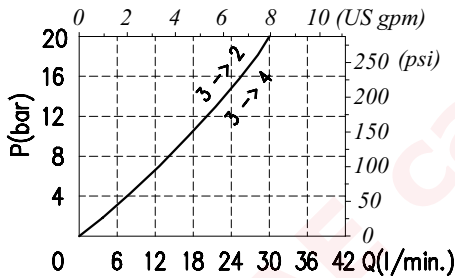

Order code

ET 10A / 20 □ - □

Manual override option
(see page 163)

N) No emergency (standard)
P) Button

Seals

B) Buna
V) Viton

Dimensions and hydraulic circuit

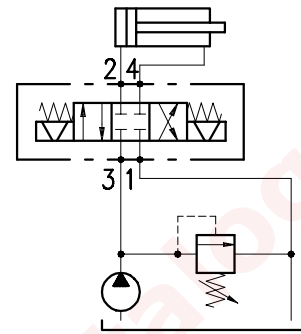
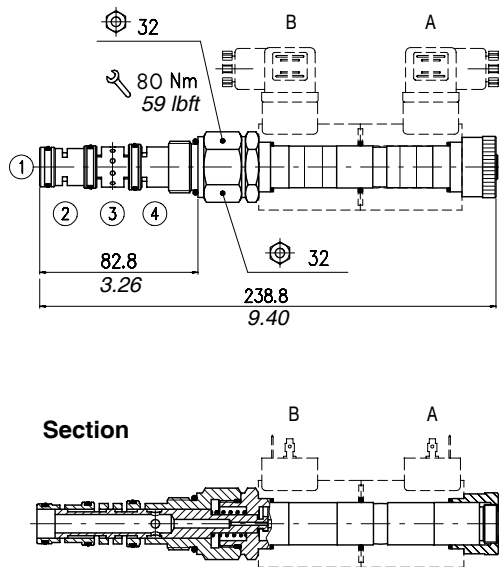

Typical pressure drop vs. flow characteristics

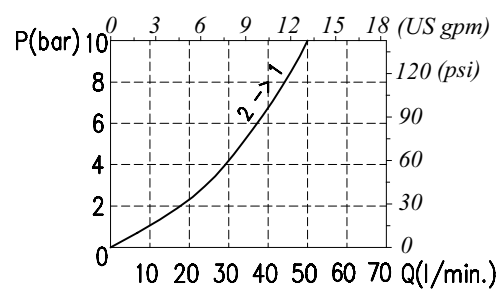
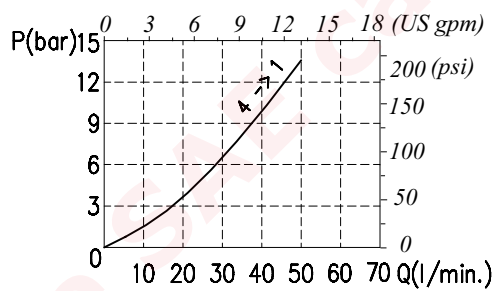
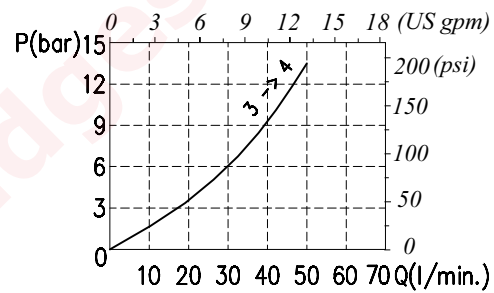
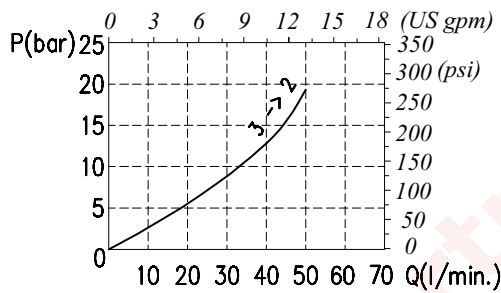

Order code

ET 12A / 20 □ - □

Manual override option
(see page 163)

N) No emergency (standard)
P) Button

Seals

B) Buna
V) Viton

Dimensions and hydraulic circuit

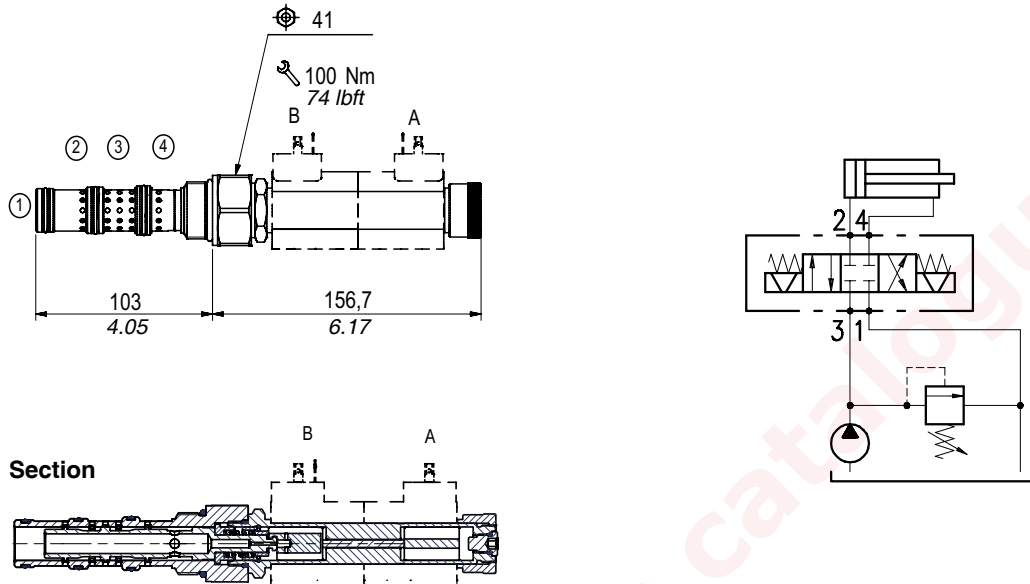

Rating diagrams

Typical pressure drop vs. flow characteristics

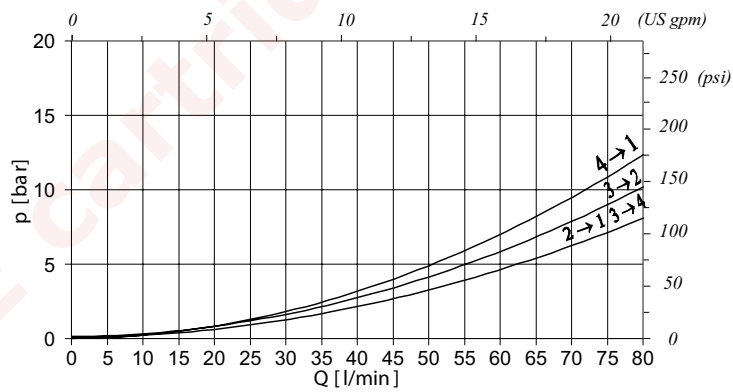

Order code

ET 16A / 20 □ - □

Manual override option

(see page 163)

N) No emergency (standard)
P) Button

Seals

B) Buna
V) Viton

Dimensions and hydraulic circuit

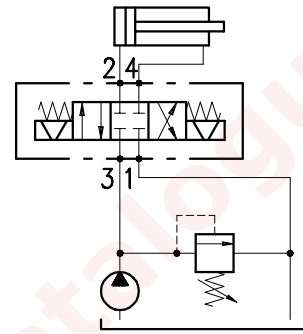
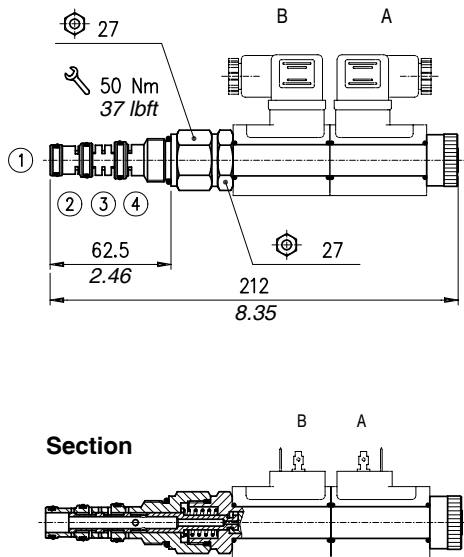

Typical pressure drop vs. flow characteristics

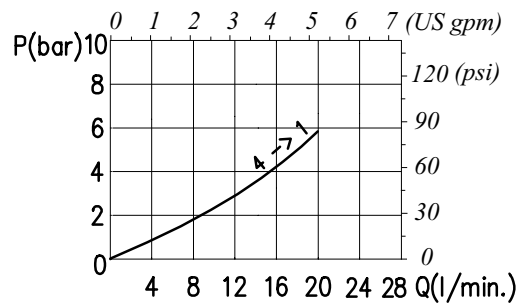
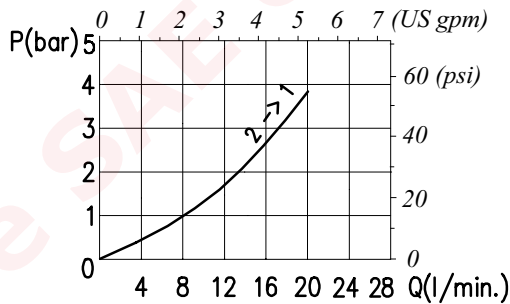
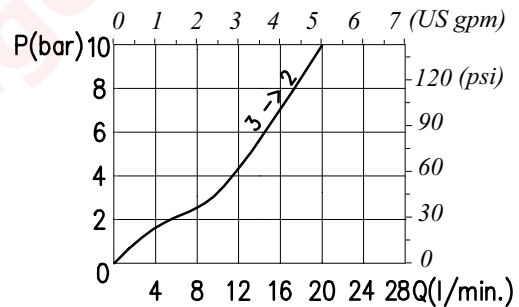
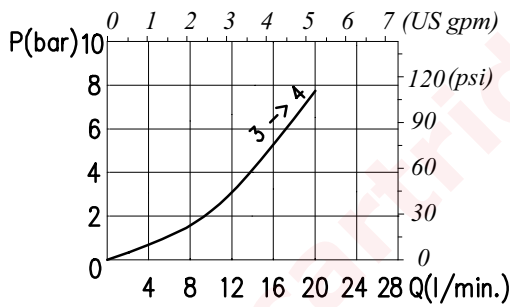

Order code

ET 10B / 20 □ - □

Manual override option
(see page 163)

N) No emergency (standard)
P) Button

Seals

B) Buna
V) Viton



Operation

When the solenoid is deenergized free oil flow is provided from 3 to 1 while 2 and 4 keep shut.

When the solenoids are alternatively energized the valve provides for free oil flow from either 3 to 2 and 4 to 1 or from 3 to 4 and 2 to 1.

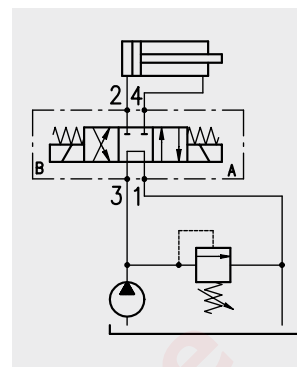

Performance

Cartridges

Type	Maximum flow		Maximum pressure		Solenoids	*Oil leaks from 1 to 2	Weight		Cavities and tools
	l/min	US gpm	bar	psi			kg	lb	
ET08M/3	15	4	210	3050	BE/EC 36 see page 157	40 cm ³ /min. - 2.44 in ³ /min at 210 bar - 3050 psi	0,250	55.11	see cavity SAE 8-4 page 173
ET10A/3	30	7.9			BIN 19 see page 158	120 cm ³ /min. - 7.32 in ³ /min at 210 bar - 3050 psi	0,310	0.68	see cavity SAE 10-4 page 173
ET12A/3	40	10.5			BIN 22 see page 159	60 cm ³ /min. - 3.66 in ³ /min at 210 bar - 3050 psi	0,720	1.59	see cavity SAE 12-4 page 173
ET10B/3	20	5.3			BC 16 see page 160	20 cm ³ /min. - 1.22 in ³ /min at 210 bar - 3050 psi	0,300	0.66	see page SAE 10-4 page 173
ET10M/3**	33	8.7			80 cm ³ /min. - 4.88 in ³ /min at 210 bar - 3050 psi	0,5	1.10		

*with oil viscosity of 46 cst

**remove the air inside unscrewing the plug

Dimensions and hydraulic circuit

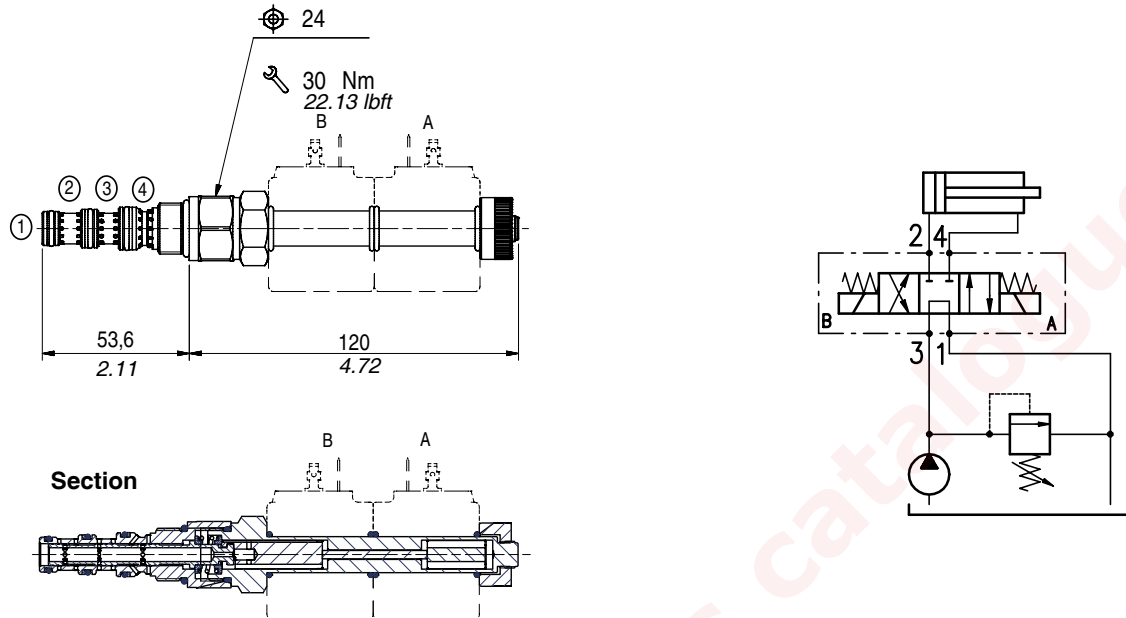

Rating diagrams

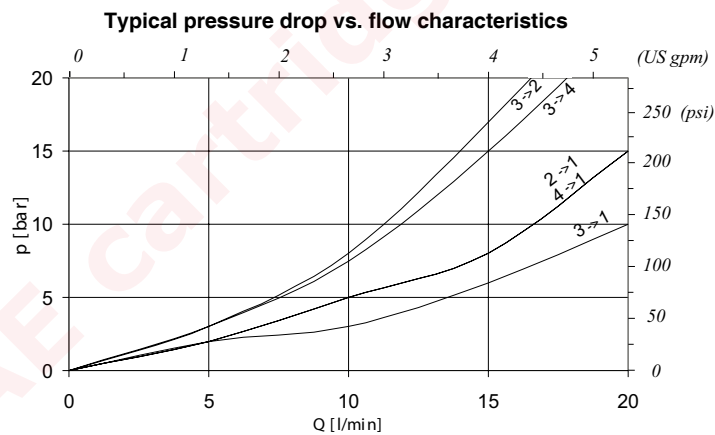

Order code

ET 08M / 30 □ - □

Manual override option

(see page 163)

N) No emergency

D) Push-pull with
mechanical detent

Seals

B) Buna

V) Viton

Dimensions and hydraulic circuit

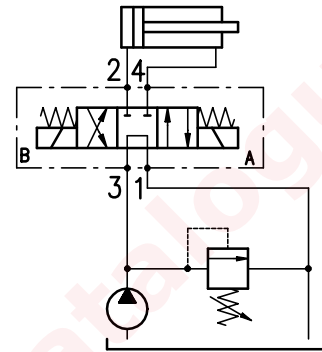
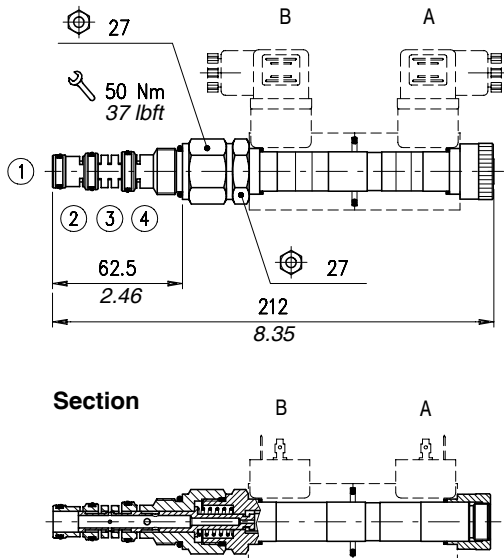

Typical pressure drop vs. flow characteristics

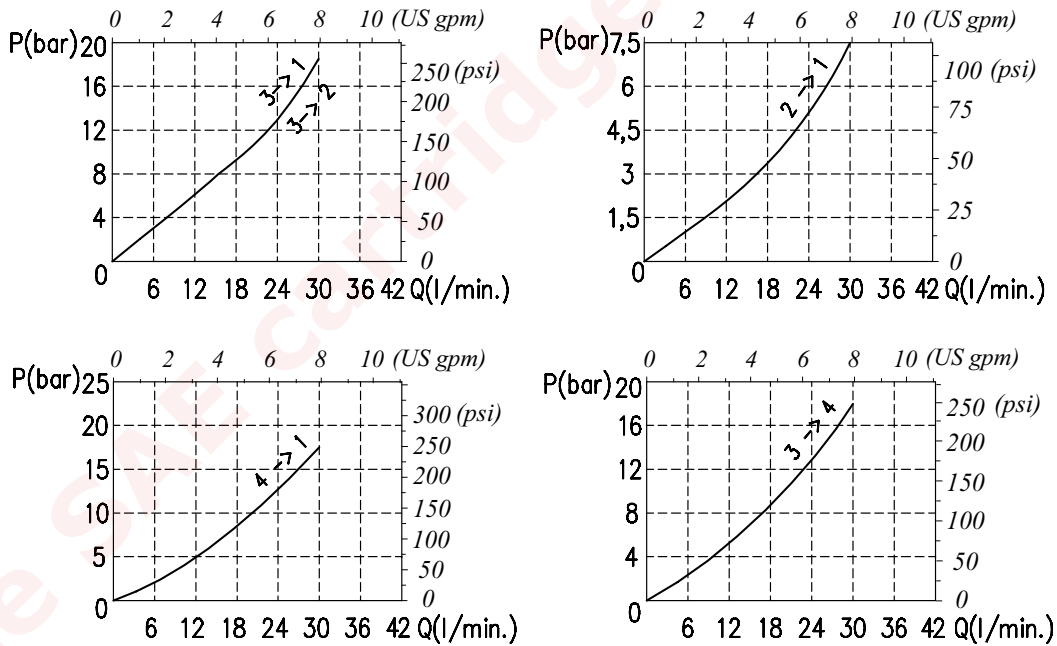

Order code

ET 10A / 30 □ - □

Manual override option
(see page 163)
N) No emergency (standard)
P) Button

Seals
B) Buna
V) Viton

Dimensions and hydraulic circuit

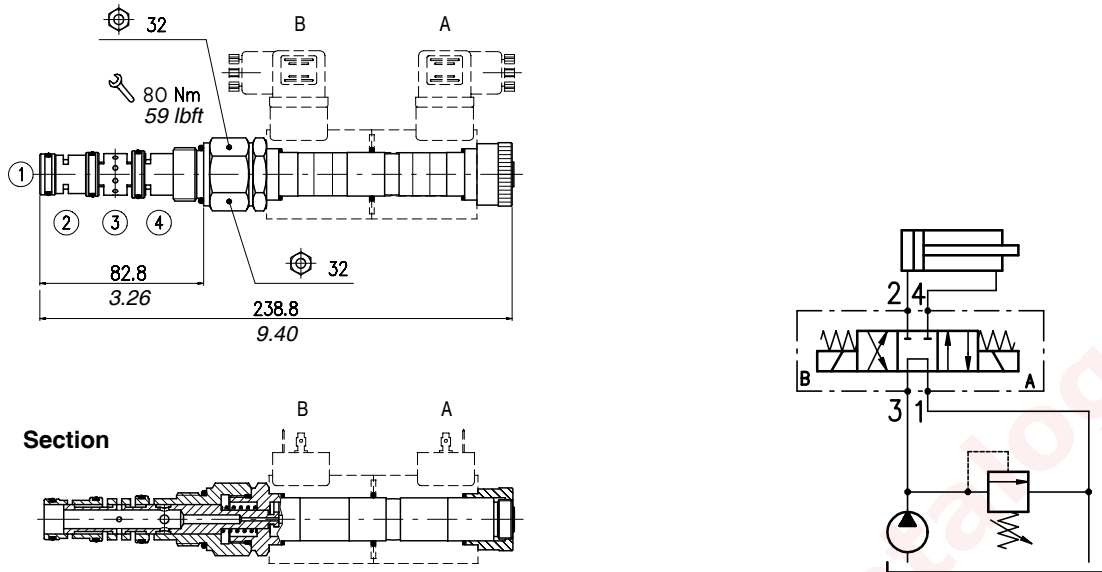

Rating diagrams

Typical pressure drop vs. flow characteristics

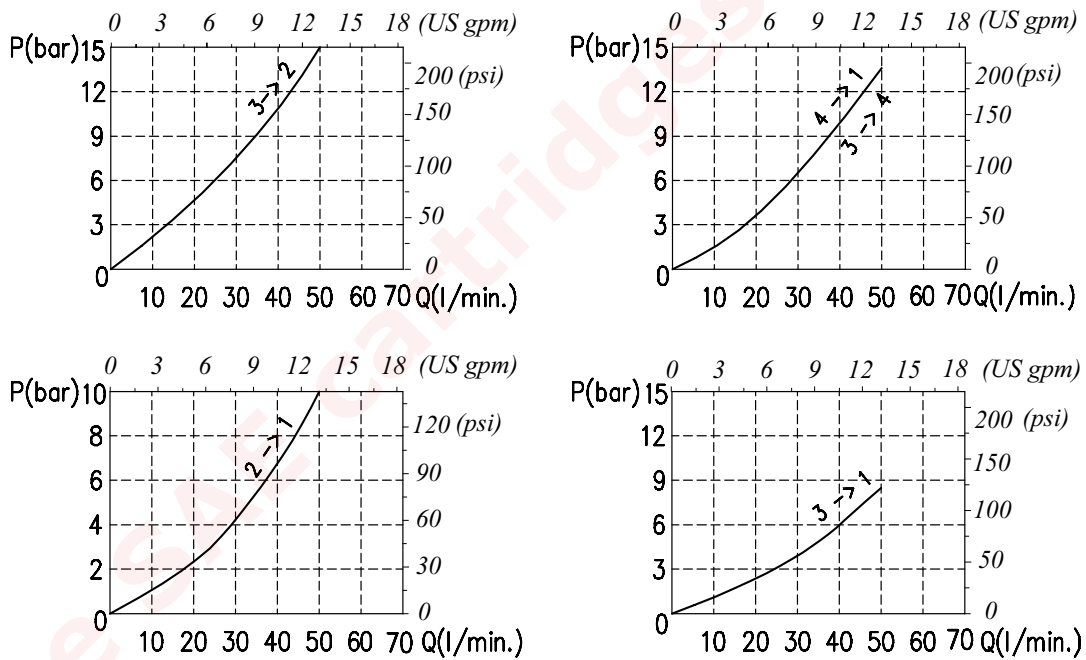

Order code

ET 12A / 30 □ - □

Manual override option
(see page 163)

N) No emergency (standard)
P) Button

Seals

B) Buna
V) Viton

Dimensions and hydraulic circuit

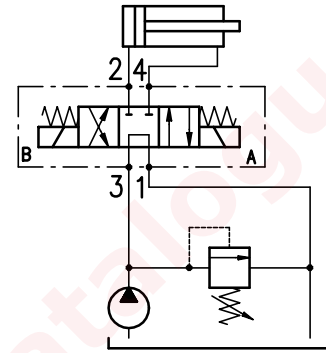
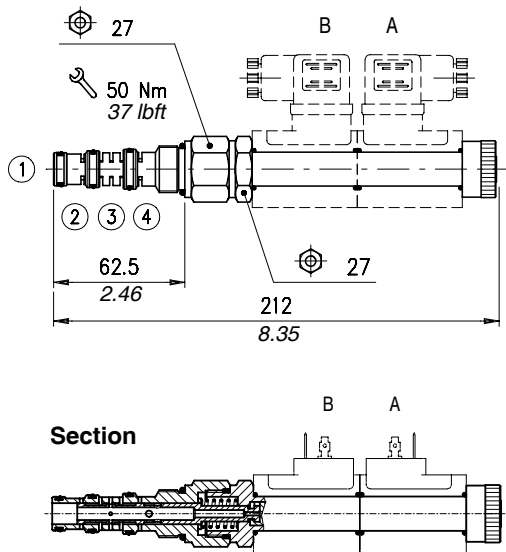

Typical pressure drop vs. flow characteristics

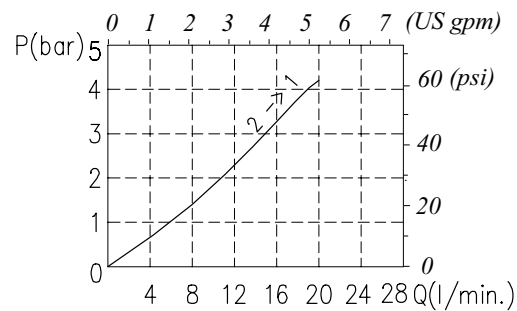
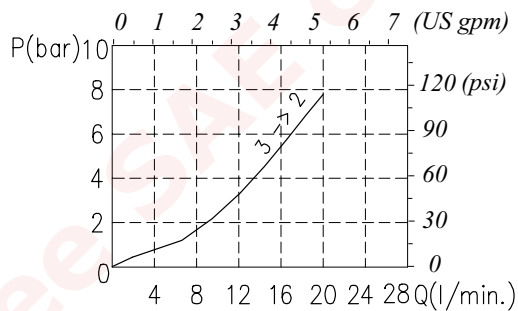
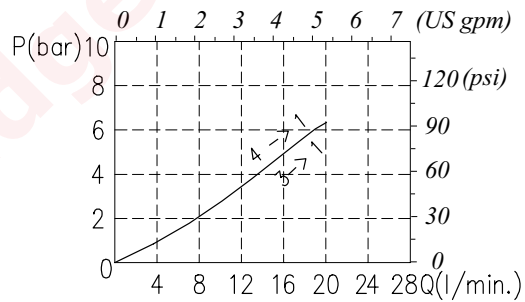
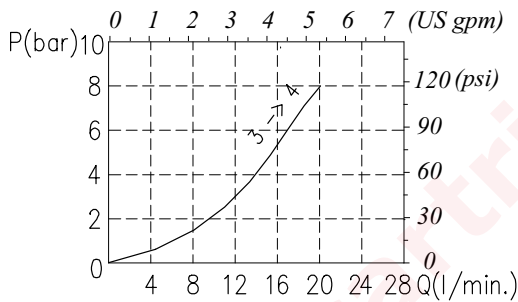

Order code

ET 10B / 30 □ - □

Manual override option
(see page 163)

N) No emergency (standard)
P) Button

Seals

B) Buna
V) Viton

Dimensions and hydraulic circuit

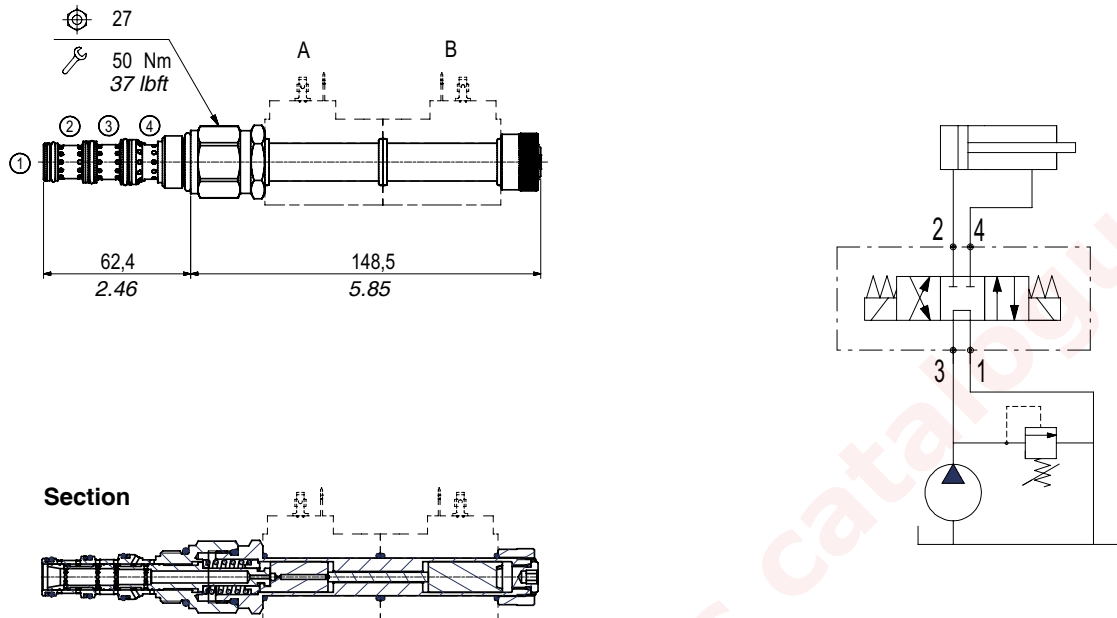

Rating diagrams

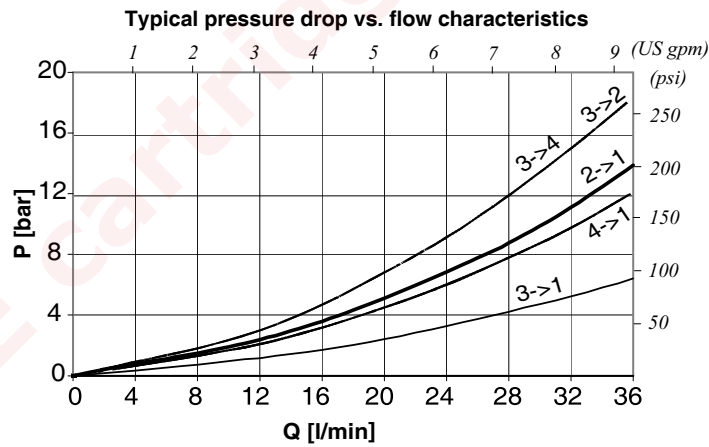

Order code

ET10M/30 -

Manual override option
(see page 163)

N) No emergency (standard)
P) Button

Seals

B) Buna
V) Viton

Operation

When the solenoid is deenergized the valve provides for connection of all ways in 1, 2 and 4 while the way in 3 is shut. When the solenoids are alternatively energized the valve provides for free oil flow from either 3 to 2 and 4 to 1 or from 3 to 4 and 2 to 1.

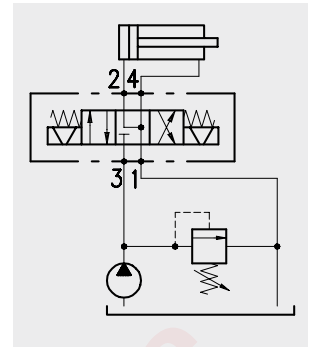

Performance

Cartridges

Type	Maximum flow		Maximum pressure		Solenoids	*Oil leaks from 1 to 2	Weight		Cavities and tools
	l/min	US gpm	bar	psi			kg	lb	
ET08C/4	8	2.1	210	3050	BE/EC 36 see page 157	10 cm ³ /min. - 0.61 in ³ /min at 210 bar - 3050 psi	0,320	0.70	see cavity SAE 8-4 page 173
ET08M/4	18	5				40 cm ³ /min. - 2.44 in ³ /min at 210 bar - 3050 psi	0,250	0.55	
ET10M/4	40	10.5			BC 16 see page 160	80 cm ³ /min. - 4.88 in ³ /min at 210 bar - 3050 psi	0,500	1.10	see cavity SAE 10-4 page 173
ET10A/4	30	8			BIN 19 see page 158	120 cm ³ /min. - 7.32 in ³ /min at 210 bar - 3050 psi	0,310	0.68	
ET12A/4	40	10.5			BIN 22 see page 159	60 cm ³ /min. - 3.66 in ³ /min at 210 bar - 3050 psi	0,720	1.59	see cavity SAE 12-4 page 173
ET10B/4	20	5.3			BC 16 see page 160	20 cm ³ /min. - 1.22 in ³ /min at 210 bar - 3050 psi	0,300	0.66	see cavity SAE 10-4 page 173

*with oil viscosity of 46 cst

Dimensions and hydraulic circuit

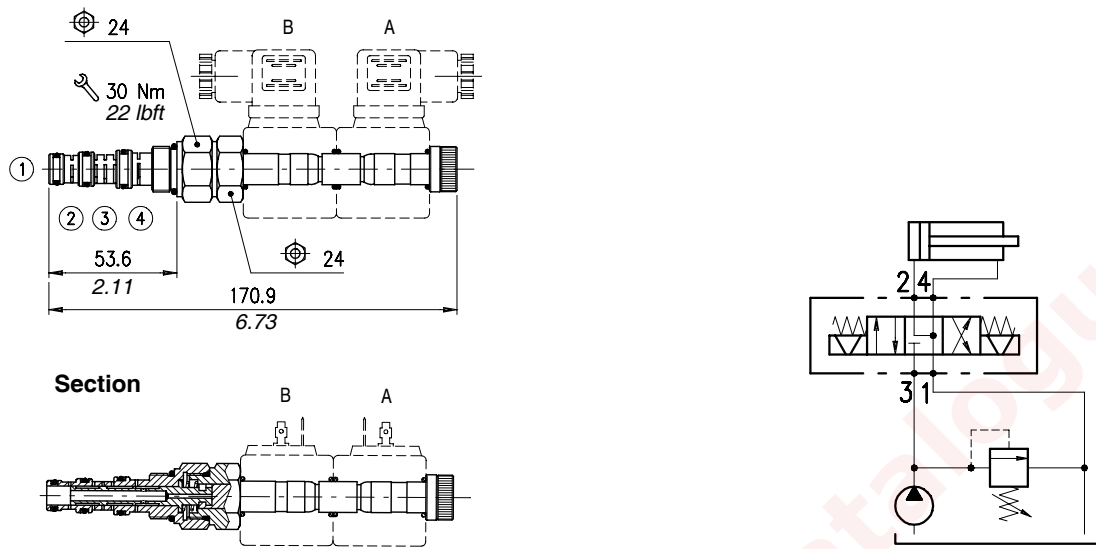

Rating diagrams

Typical pressure drop vs. flow characteristics

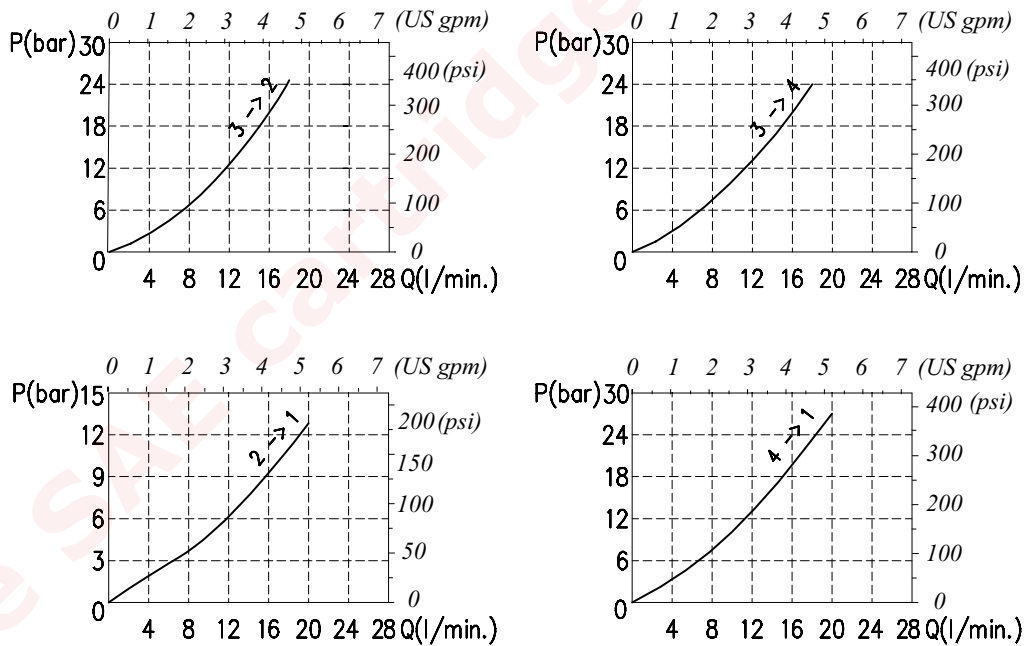

Order code

ET 08C / 40 N □

Seals

B) Buna
V) Viton

Dimensions and hydraulic circuit

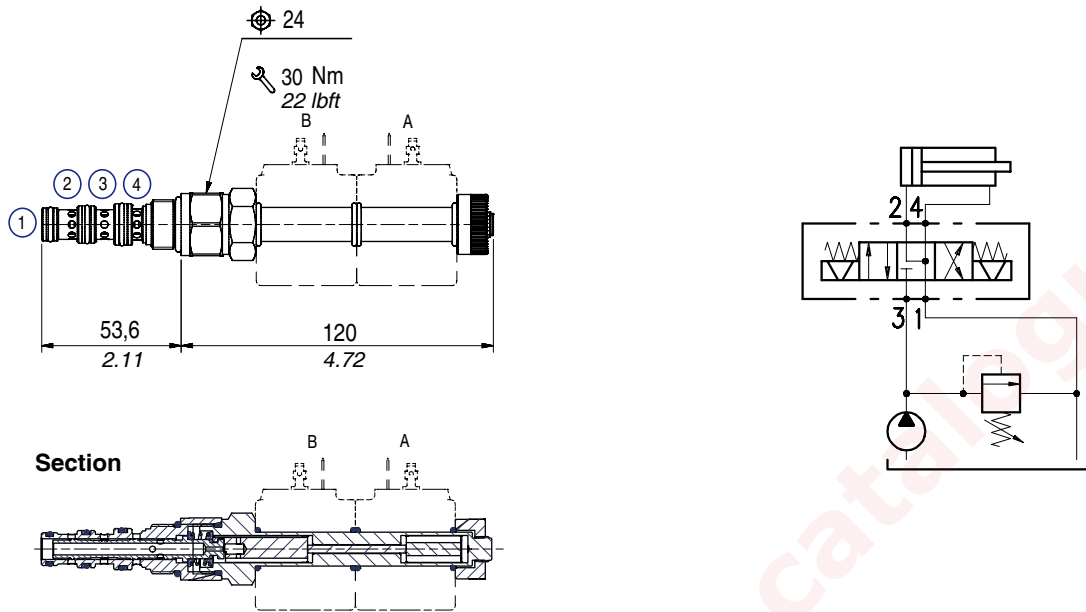

Typical pressure drop vs. flow characteristics

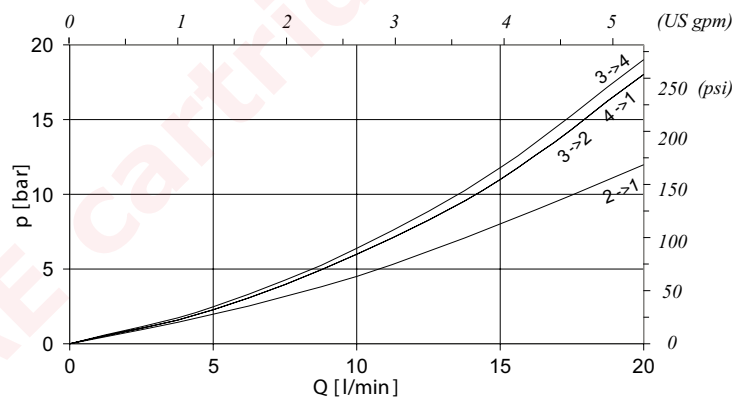

Order code

ET 08M / 40 □ - □

Manual override option
(see page 163)

- N)** No emergency (standard)
- D)** Push-pull with mechanical detent

Seals

- B)** Buna
- V)** Viton

Dimensions and hydraulic circuit

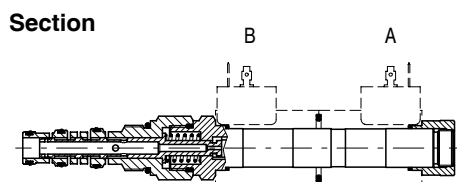
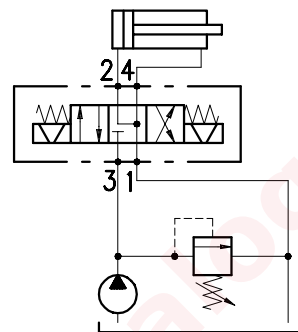
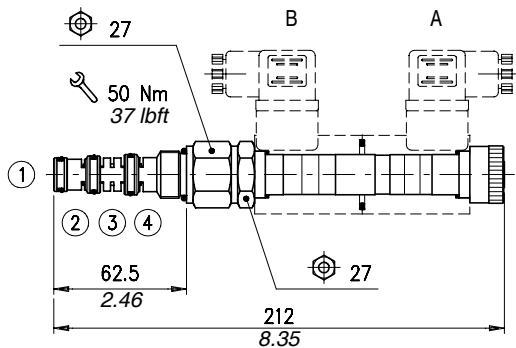

Rating diagrams

Typical pressure drop vs. flow characteristics

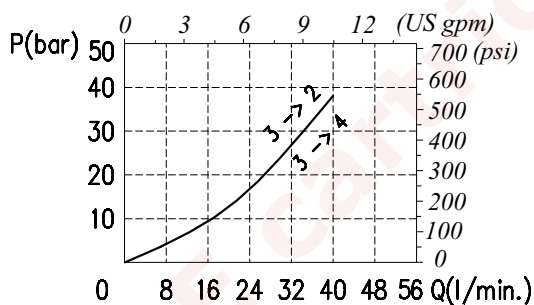

Typical pressure drop vs. flow characteristics

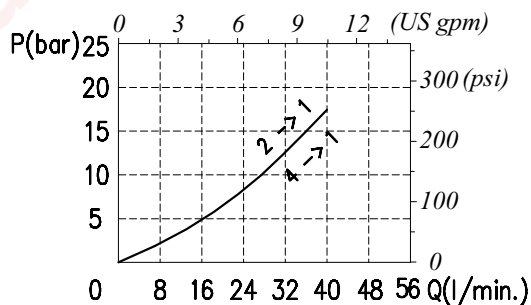

Order code

ET 10A / 40 □ - □

Manual override option
(see page 163)

N) No emergency (standard)
P) Button

Seals

B) Buna
V) Viton

Dimensions and hydraulic circuit

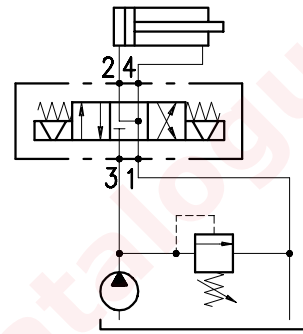
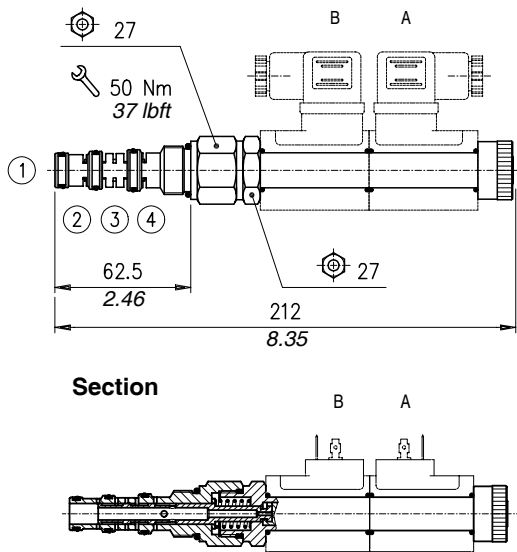

Typical pressure drop vs. flow characteristics

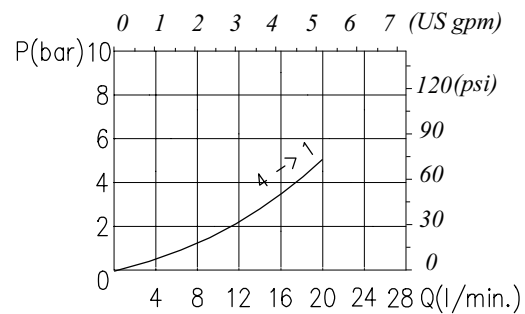
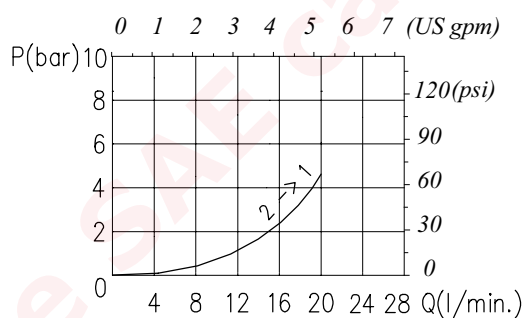
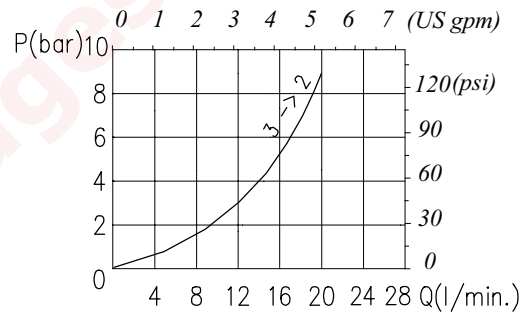
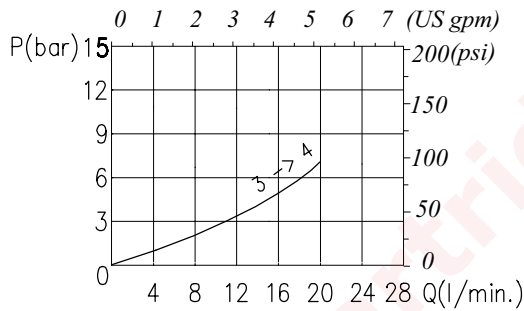

Order code

ET 10B / 40 □ - □

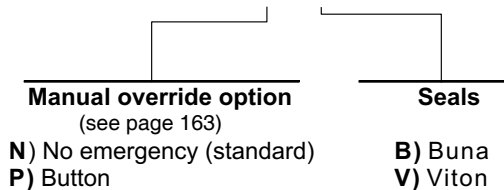

Dimensions and hydraulic circuit

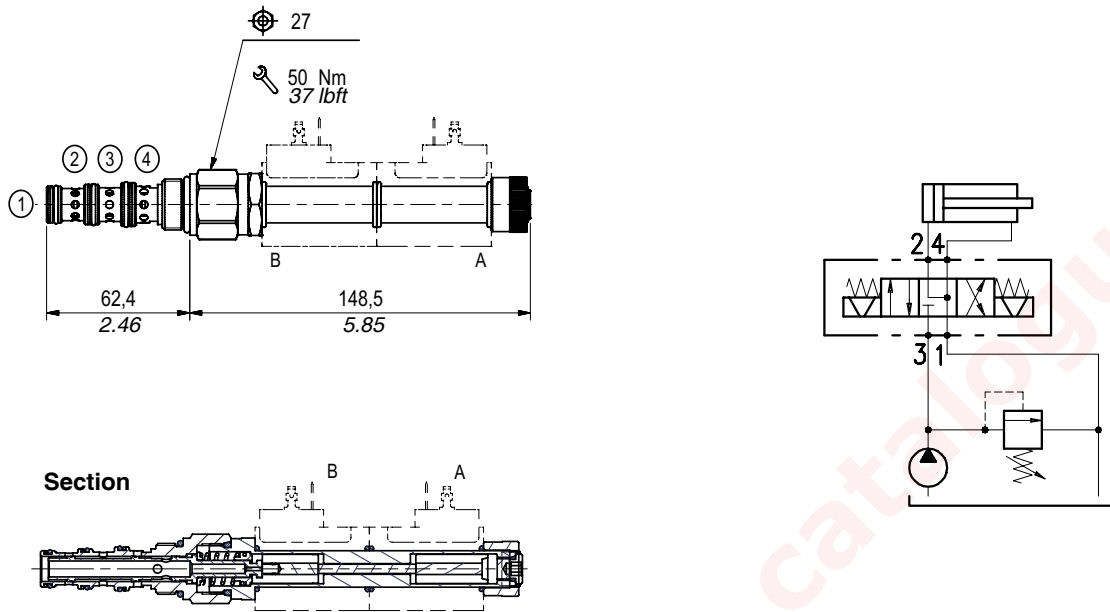

Rating diagrams

Typical pressure drop vs. flow characteristics

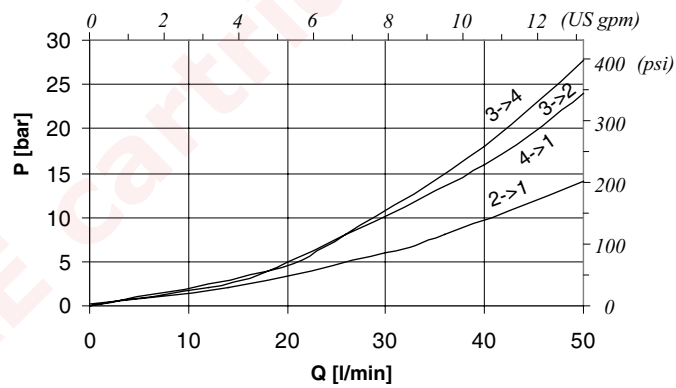

Order code

ET 10M / 40 □ - □

Manual override option
(see page 163)

- N)** No emergency (standard)
- D)** Push-pull with mechanical detent
- P)** Button
- E)** Push-pull with spring detent

Seals

- B)** Buna
- V)** Viton

Dimensions and hydraulic circuit

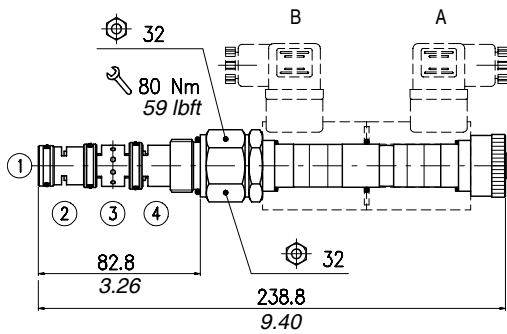

Section

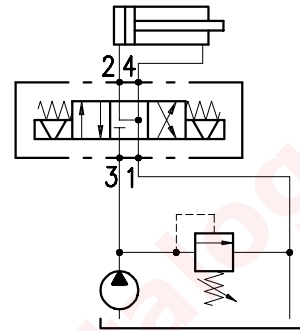
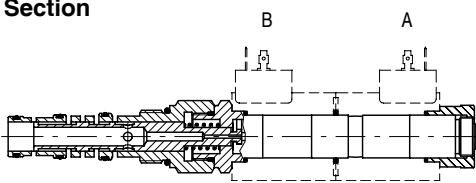

Typical pressure drop vs. flow characteristics

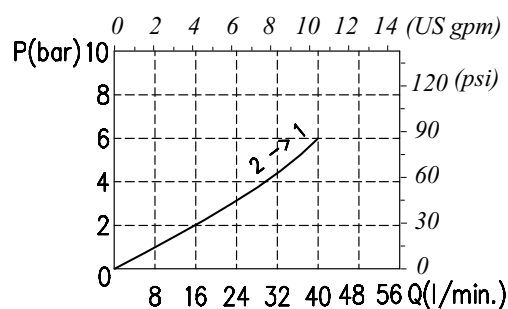
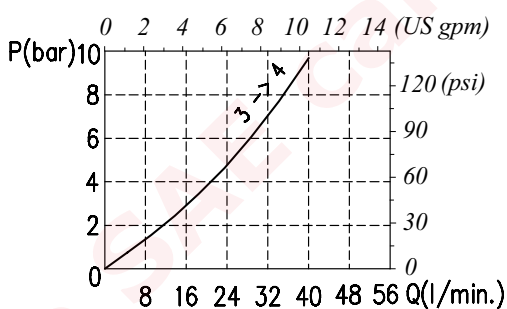
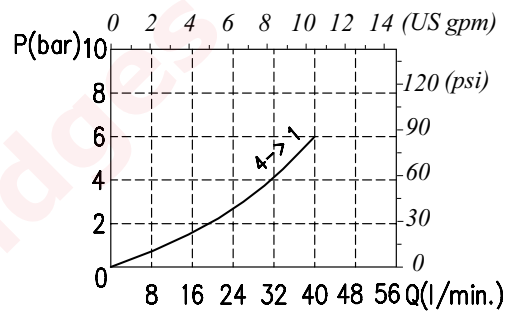
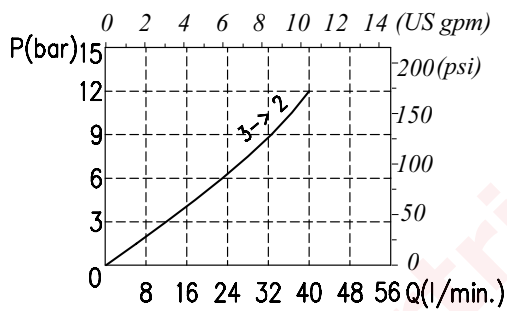

Order code

ET 12A / 40 □ - □

Manual override option
(see page 163)
N) No emergency (standard)
P) Button

Seals
B) Buna
V) Viton



Operation

In the NC (normally closed) valve version, the oil flow is stopped from E to U and is open from U to E when the pneumatic pilot is dropped out. When the pneumatic pilot is operated the flow is free both from E to U and vice versa. When the pneumatic pilot is dropped out, the pressure drop from U to E is high.

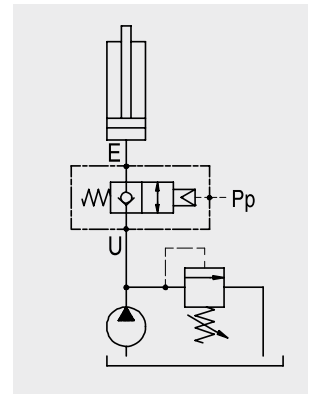

Performance

Cartridges

Type	Maximum flow		Maximum pressure		Pilot pressure		*Oil leaks from E to U	Weight		Cavities and tools
	l/min	US gpm	bar	psi	bar	psi		kg	lb	
VSE/P/2-40 NC	40	10.5	350	5100	min 4	min 58	0,25 cm ³ /min. - 0.015 in ³ /min (5 drops) at 210 bar - 3050 psi	0,32	0.70	see cavity SAE 8-2 page 171
VSE/P/2-70 NC	70	18			max 15	max 217.5		0,36	0.79	see cavity VSE/P/2-70 page 174
VSE/P/2-150 NC	150	40			0,46	1.01		see cavity VSE/P/2-150 page 175		

*with oil viscosity of 46 cst

Dimensions and hydraulic circuit

Valve	L	C	Wr	M	Pp
VSE/P/2-40 NC	104.2 - 4.10	26.6 - 0.05	27	30 - 1.18	G1/8
VSE/P/2-70 NC	112.6 - 4.43	38 - 1.50	32	75 - 2.95	G1/8
VSE/P/2-150 NC	115.6 - 4.55	48 - 1.89	38	95 - 3.74	G1/8

Dimensions are in mm - in

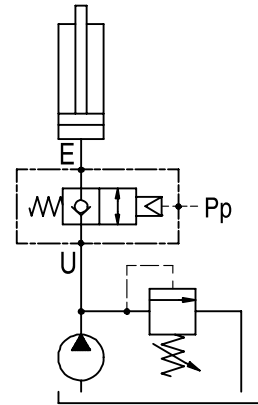
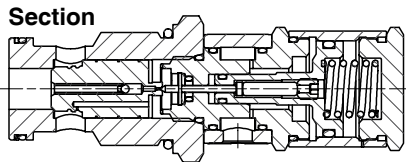
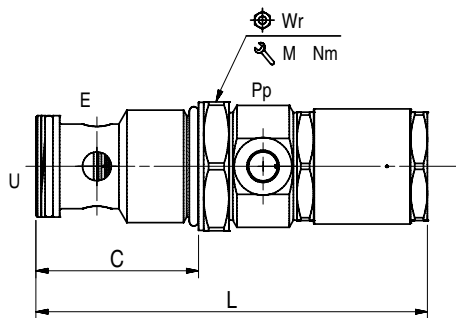

Rating diagrams

Typical pressure drop vs. flow characteristic VSE /P /2-150

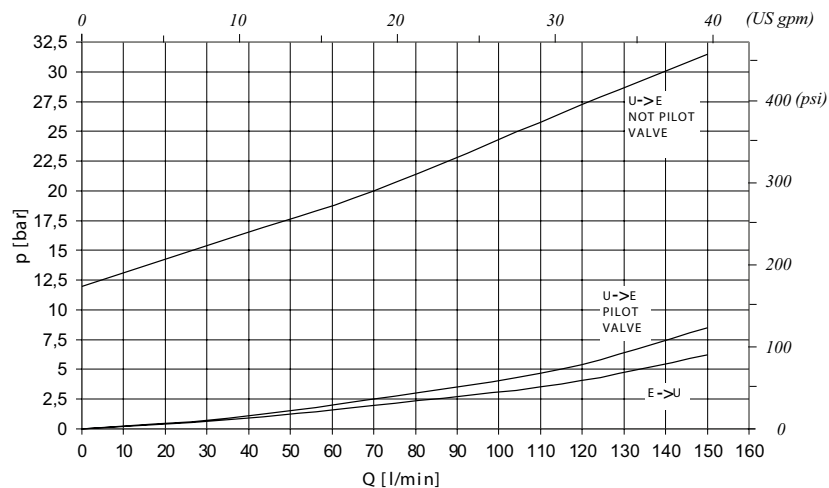

Type VSE /P /2-.. NC pneumatic operated

Typical pressure drop vs. flow characteristic VSE /P /2-70

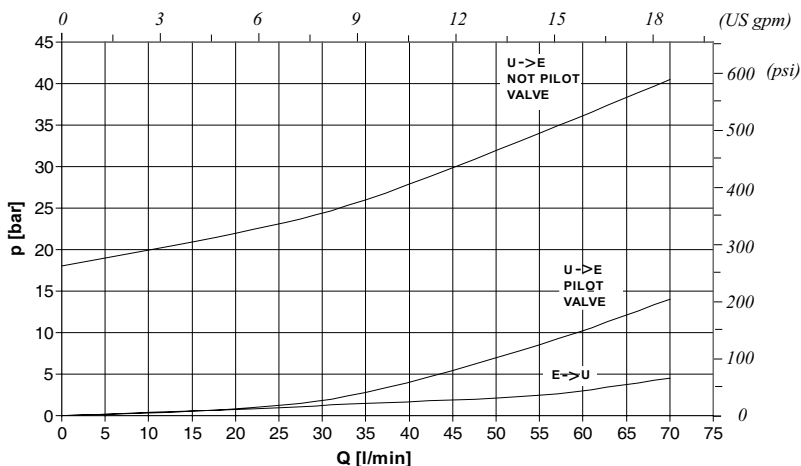

Typical pressure drop vs. flow characteristic VSE /P /2-40

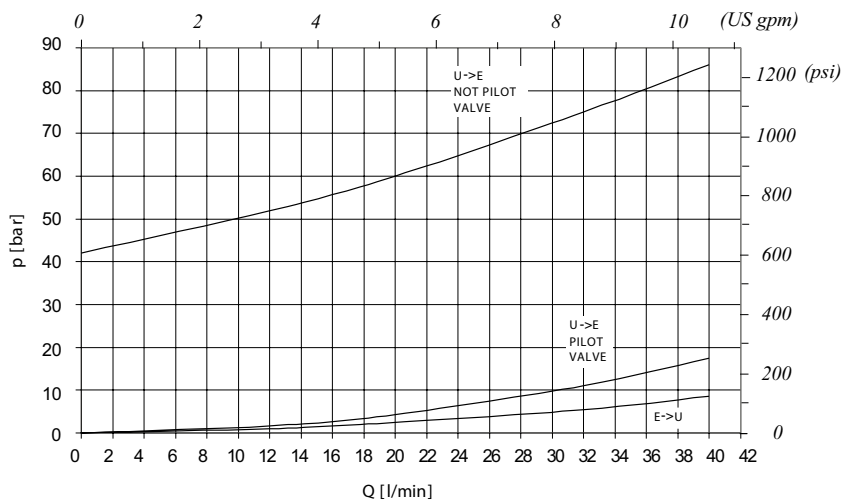

Order code

VSE /P /2 - □ /NC PNEUMATIC OPERATED

Max. Flow

- 150-Q=150 l/min. 40 USgpm
- 70-Q=70 l/min 18 USgpm
- 40-Q=40 l/min 11 USgpm



Operation

In the NA (normally opened) valve version, the oil flow is free from E to U and vice versa when the pneumatic pilot is dropped out. When the pneumatic pilot is operated the flow is stopped from E to U and is open in the opposite direction. When the pneumatic pilot is operated, the pressure drop is high due to the pilot pressure.

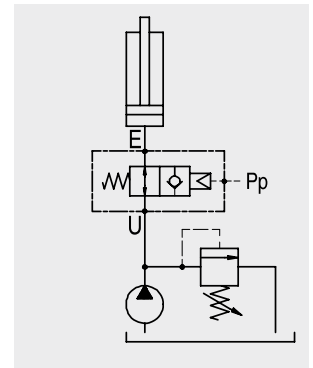

Performance

Cartridges

Tipo	Maximum flow		Maximum pressure		Pilot pressure		Oil leaks from E to U	Weight		Cavities and tools
	l/min	US gpm	bar	psi	bar	psi		kg	lb	
VSE/P/2-40 NA	40	10.5	350	5100	min 4	min 58	0,25 cm ³ /min. - 0.015 in ³ /min (5 drops) at 210 bar - 3050 psi	0,26	0.57	SAE 8-2 see page 171
VSE/P/2-70 NA	70	18			max 15	max 217.5		0,3	0.66	VSE/P/2-70 see page 174
VSE/P/2-150 NA	150	40						0,4	0.88	VSE/P/2-150 see page 175

Dimensions and hydraulic circuit

Valve	L	C	Wr	M	Pp
VSE/P/2-40 NA	84.2 - 3.31	26.6 - 1.05	27	30 - 1.18	G1/8
VSE/P/2-70 NA	92.6 - 3.64	38 - 1.50	32	75 - 2.95	G1/8
VSE/P/2-150 NA	95.6 - 3.76	48 - 1.89	38	95 - 3.74	G1/8

Dimensions are in mm - in

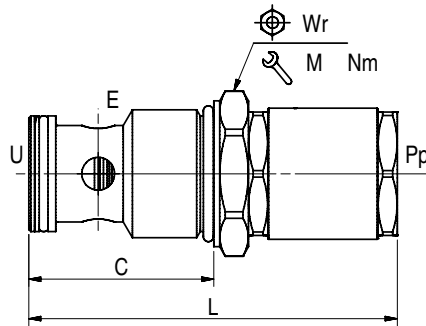

Section

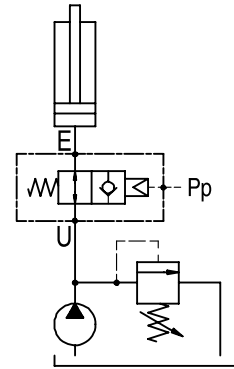
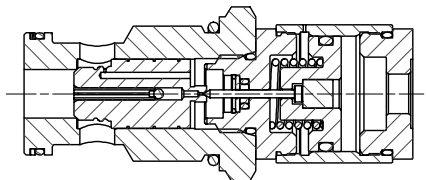

Rating diagrams

Typical pressure drop vs. flow characteristic VSE /P /2-150

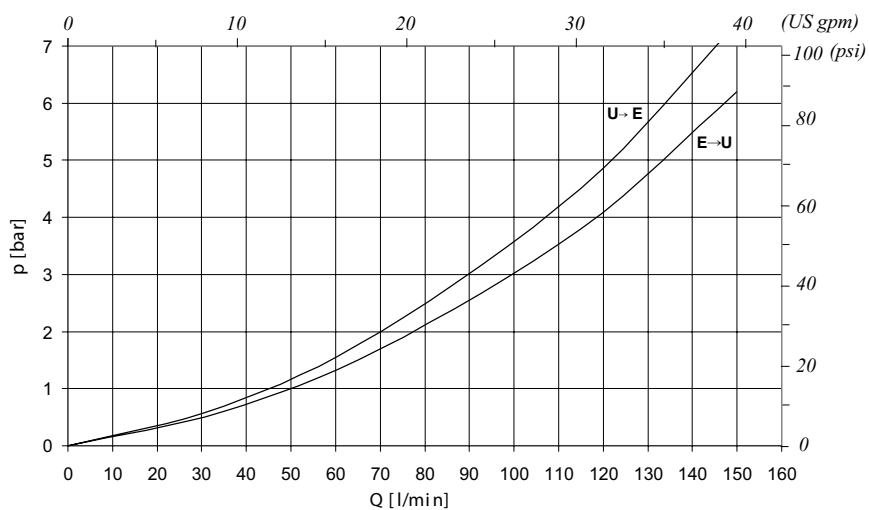

Type VSE /P /2-.. NA pneumatic operated

Typical pressure drop vs. flow characteristic VSE /P /2-70

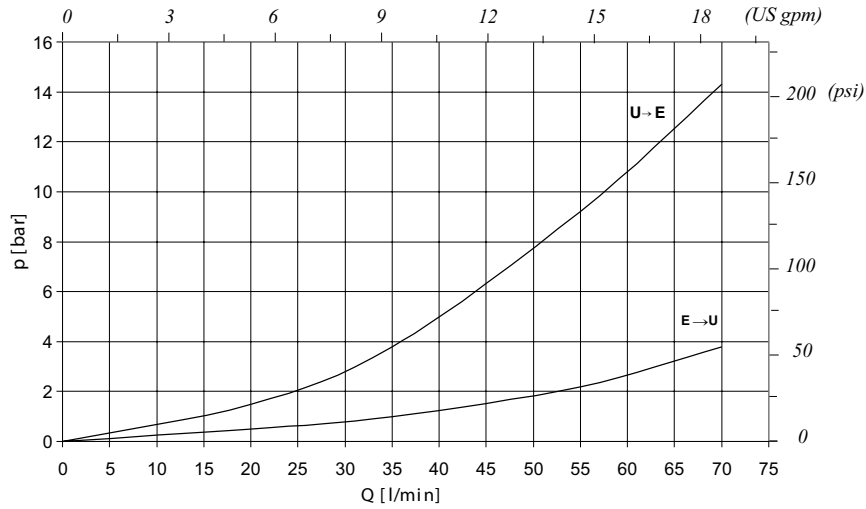

Typical pressure drop vs. flow characteristic VSE /P /2-40

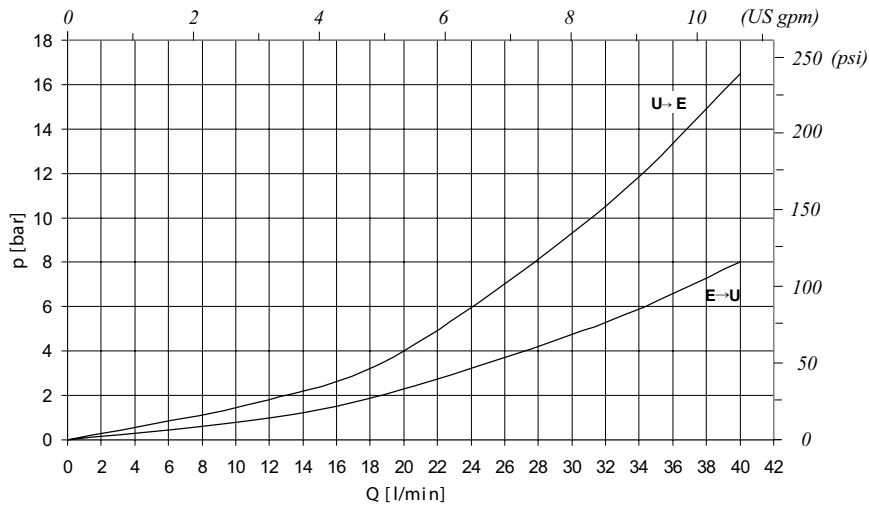

Order code

VSE /P /2 - □ /NA PNEUMATIC OPERATED

Max. Flow

- 150-Q=150 l/min 40 USgpm
- 70-Q=70 l/min 18 USgpm
- 40-Q=40 l/min 11 USgpm



Operation

Multiple coil versions are available to allow use with direct and alternated current.

Thermal insulation class: F (Tmax = 155°C) – (VDE 0580)

Relative duty cycle: ED 100% (VDE 0580)

To assure ED = 100% and perform continuous coil operation, the following conditions should be met:

TA + ΔT < Tmax

Whereas:

-TA = ambient temperature

-ΔT = temperature increase due to operation

-Tmax = maximum admissible temperature according to insulation class

We therefore recommend always checking that the maximum ambient temperature is same as Tmax - ΔT (providing no special operating requirement are there).

Safety standards (DIN 40050): IP54 without connector

IP65 with connector

Admissible voltage range for long lasting and trouble free operations life: nominal voltage ±10%

Performance

Type	Resistance Ω T _A =20°C 68°F	Current (A)		Power (W) or (VA) Cold	ΔT	
		Cold	Warm		After 1 hour at: -T _A =20-25°C 68-77°F -Nominal voltage	
					C°	F°
BE 12 Vcc	7,7	1,56	1,16	18,7 W	110	230
BE 24 Vcc	31	0,77	0,58	18,6 W	110	230
BE 48 Vcc	116	0,41	0,3	19,8 W	115	238
BE 110 Vcc	700	0,157	0,12	17,3 W	105	221
BE 24 Vca (50 Hz)	5,3	1,16	0,87	28 VA	105	221
BE 48 Vca (50 Hz)	21,3	0,6	0,45	28,8 VA	105	221
BE 110 Vca (50 Hz)	108	0,26	0,19	28,6 VA	105	221
BE 220 Vca (50 Hz)	438	0,13	0,09	28,6 VA	105	221
BE 380 Vca (50 Hz)	1400	0,09	0,06	34,2 VA	105	221
BE 24 RAC	27	0,8	0,6	17,3 W	105	221
BE 110 RAC	630	0,157	0,12	15,6 W	100	212
BE 220 RAC	2500	0,08	0,06	15,7 W	100	212
BT 12 Vcc	6,8	1,77	1,15	21 W	-	-
BT 24 Vcc	27	0,89	0,58	21 W	-	-
BT 48 Vcc	110	0,43	0,32	20,3 W	105	221
BT 110 Vcc	700	0,15	0,11	15,7 W	100	212
BT 24 Vca (50 Hz)	4,2	0,94	0,83	22,6 VA	-	-
BT 48 Vca (50 Hz)	15,3	0,73	0,54	35 VA	105	221
BT 110 Vca (50 Hz)	89	0,21	0,18	23,1 VA	-	-
BT 220 Vca (50 Hz)	350	0,1	0,08	22 VA	-	-
BT 24 RAC	90	0,47	0,37	20,7 W	105	221
BT 110 RAC	540	0,2	0,16	21,6 W	110	230
BT 220 RAC	2170	0,1	0,08	21,7 W	105	221

Dimensions

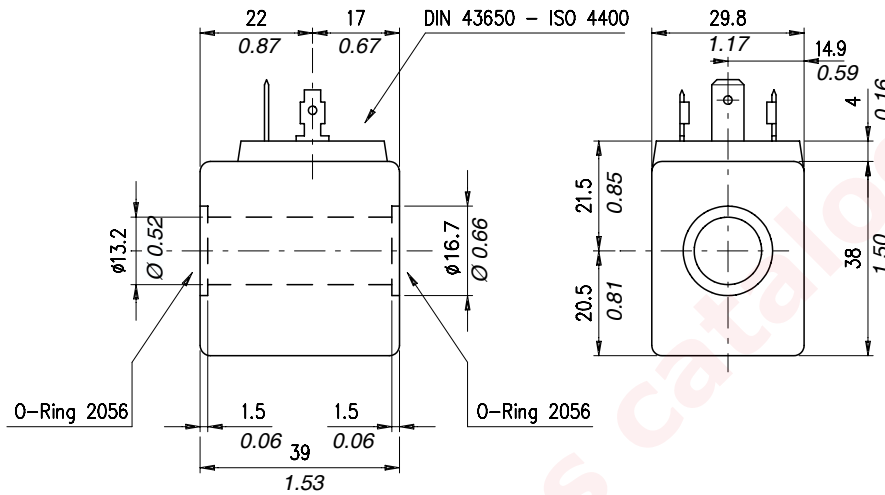

Order code

Type	Ordering code	Ordering code with standard connector	Standard connector code	Connector page
BE 12 Vcc	4SL1000120	5SL1000120	4CN1009990	Page 162 CC-CA
BE 24 Vcc	4SL1000240	5SL1000240		
BE 48 Vcc	4SL1000480	5SL1000480		
BE 110 Vcc	4SL1001100	5SL1001100		
BE 24 Vca (50 Hz)	4SL1010240	5SL1010240		
BE 48 Vca (50 Hz)	4SL1010480	5SL1010480		
BE 110 Vca (50 Hz)	4SL1011100	5SL1011100		
BE 220 Vca (50 Hz)	4SL1012200	5SL1012200		
BE 380 Vca (50 Hz)	4SL1013800	5SL1013800		
BE 24 RAC	4SL1030240	5SL1030240	4CN1010240	Page 162 CL
BE 110 RAC	4SL1031100	5SL1031100	4CN1011100	
BE 220 RAC	4SL1032200	5SL1032200	4CN1012200	

Dimensions

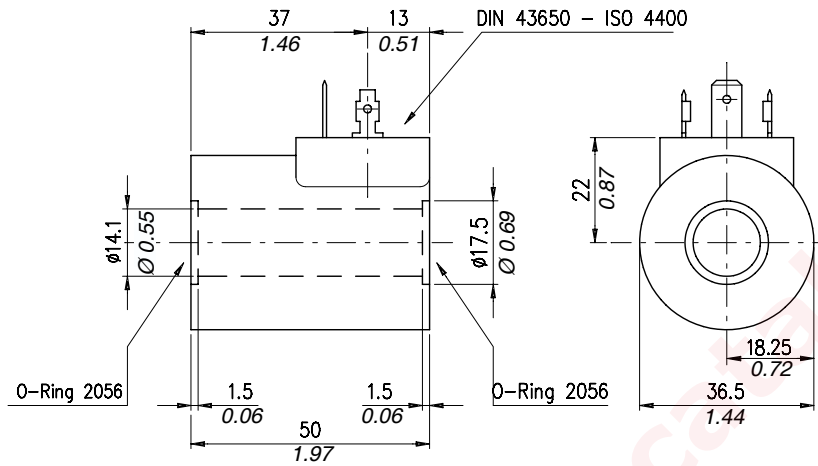

Order code

Type	Ordering code	Ordering code with standard connector	Standard connector code	Connector page
BT 12 Vcc	4SL3000120	5SL3000120	4CN1009990	Page 162 CC-CA
BT 24 Vcc	4SL3000240	5SL3000240		
BT 48 Vcc	4SL3000480	5SL3000480		
BT 110 Vcc	4SL3001100	5SL3001100		
BT 24 Vca (50 Hz)	4SL3010240	5SL3010240		
BT 48 Vca (50 Hz)	4SL3010480	5SL3010480		
BT 110 Vca (50 Hz)	4SL3011100	5SL3011100		
BT 220 Vca (50 Hz)	4SL3012200	5SL3012200		
BT 24 RAC	4SL3030240	5SL3030240	4CN3010240	Page 162 CP
BT 48 RAC	4SL3030480	5SL3030480	4CN3010480	
BT 110 RAC	4SL3031100	5SL3031100	4CN3011100	
BT 220 RAC	4SL3032200	5SL3032200	4CN3012200	

Coil BE-EC

Operation

Multiple coil versions are available to allow use with direct and alternated current.

Thermal insulation class: F ($T_{max} = 180^{\circ}\text{C}$) – (VDE 0580)

Relative duty cycle: ED 100% (VDE 0580)

To assure ED = 100% and perform continuous coil operation, the following conditions should be met:

$T_A + \Delta T < T_{max}$

Whereas:

- T_A = ambient temperature

- ΔT = temperature increase due to operation

- T_{max} = maximum admissible temperature according to insulation class

We therefore recommend always checking that the maximum ambient temperature is same as $T_{max} - \Delta T$ (providing no special operating requirement are there).

Safety standards (DIN 40050): IP54 without connector

IP65 with connector

Admissible voltage range for long lasting and trouble free operations life: nominal voltage $\pm 10\%$

Performance

Type	Resistance Ω $T_A = 20^{\circ}\text{C}$ 68°F	Current (A)		Power (W) or (VA) Cold	ΔT	
		Cold	Warm		After 1 hour at: - $T_a = 20-25^{\circ}\text{C}$ $68-77^{\circ}\text{F}$ -Nominal voltage	
					$^{\circ}\text{C}$	$^{\circ}\text{F}$
BE EC36 12 Vcc	6,3	1,9	1,35	22,8 W	115	238
BE EC36 24 Vcc	25,6	0,94	0,66	22,5 W	115	238
BE EC36 24 RAC	20,2	1,07	0,75	23,1 W	115	238
BE EC36 48 RAC	80,8	0,53	0,37	23 W	115	238
BE EC36 110 RAC	420	0,23	0,16	22,8 W	115	238
BE EC36 220 RAC	1720	0,11	0,08	22,7 W	115	238

Dimensions

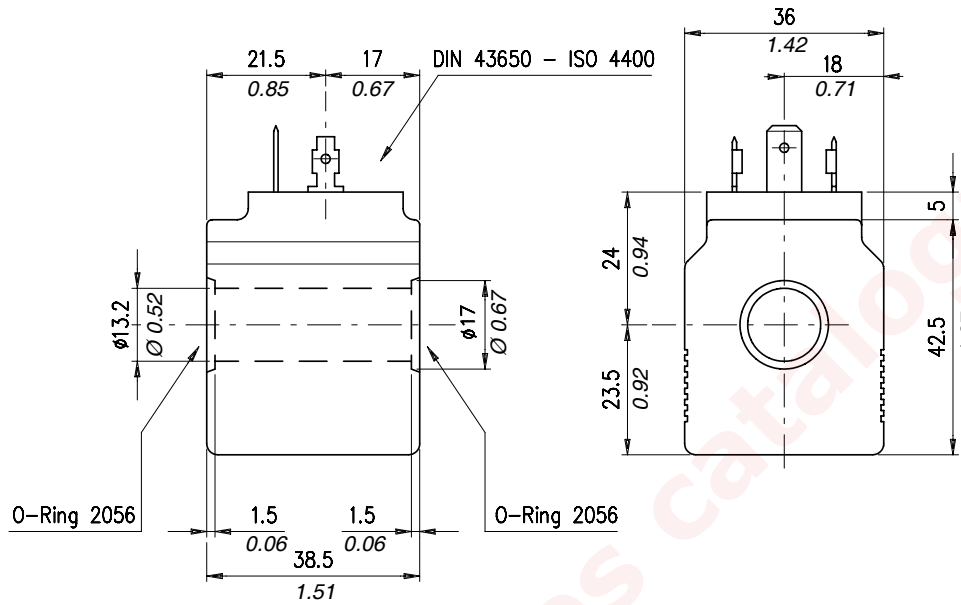

Order code

Type	Ordering code	Ordering code with standard connector	Standard connector code	Connector page
BE EC36 12 Vcc	4SL2000121	5SL1000120	4CN1009990	Page 162 CC-CA
BE EC36 24 Vcc	4SL2000241	5SL2000241		
BE EC36 24 RAC	4SL2030240	5SL2030240	4CN1010240	Page 162 CL
BE EC36 48 RAC	4SL2030480	5SL2030480	4CN1010480	
BE EC36 110 RAC	4SL2031100	5SL2031100	4CN1011100	
BE EC36 220 RAC	4SL2032200	5SL2032200	4CN1012200	

Operation

Multiple coil versions are available to allow use with direct and alternated current.

Thermal insulation class: F (Tmax=155°C)-(VDE 0580)

Relative duty cycle:ED 100% (VDE 0580)

To assure ED=100% and perform continuous coil operation, the following conditions should be met:

$T_A + \Delta T < T_{max}$

Whereas:

T_A = ambient temperature

ΔT = temperature increase due to operation

T_{max} = maximum admissible temperature according to insulation class.

We therefore recommend always checking that the maximum ambient temperature is same as T_{max}-ΔT (providing no special operating requirement are there)

Safety standards (DIN 40050):

- IP54 without connector

- IP65 with connector

Admissible voltage range for long lasting and trouble free operations life: nominal voltage ±10%

Performance

Type	Resistance Ω T _A =20°C 68°F	Current (A)		Power (W) or (VA) Cold	ΔT (°C) After 1 hour at: -T _A =20-25°C 68-77°F -Nominal voltage
		Cold	Warm		
BIN 19 12 Vcc	5,0	2,41	-	29 W	-
BIN 19 24 Vcc	18,6	1,29	-	31 W	-

Dimensions

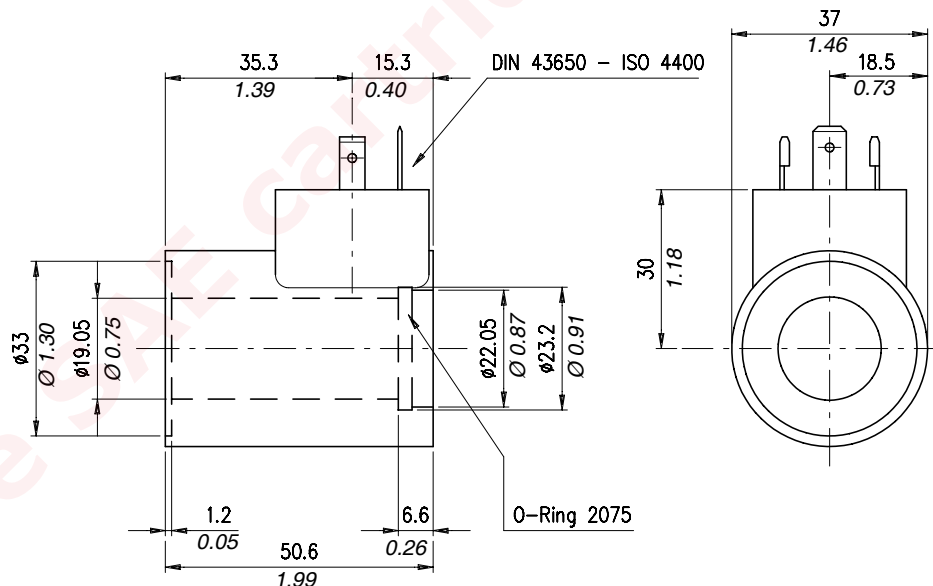

Order code

Type	Ordering code	Ordering code with standard connector	Standard connector code	Connector page
BIN 19 12 Vcc	4SL6000121	5SL6000121	4CN1009990	Page 162 CC-CA
BIN 19 24 Vcc	4SL2000240	5SL6000240		

Operation

Multiple coil versions are available to allow use with direct and alternated current.

Thermal insulation class: F(Tmax=155°C)-(VDE 0580)

Relative duty cycle: ED100% (VDE 0580)

To assure ED=100% and perform continuous coil operation, the following conditions should be met:

TA+ΔT<Tmax

Whereas:

TA = ambient temperature

TΔ= temperature increase due to operation

Tmax = maximum admissible temperature according to insulation class

We therefore recommend always checking that the maximum ambient temperature is same as Tmax -ΔT (providing no special operating requirement are there).

Safety standards (DIN 40050):

-IP54 without connector

-IP65 with connector

Admissible voltage range for long lasting and trouble free operations life: nominal voltage ±10%

Performance

Type	Resistance Ω T _A =20°C 68°F	Current (A)		Power (W) or (VA) Cold	ΔT (°C) After 1 hour at: -T _A =20-25°C 68-77°C -Nominal voltage
		Cold	Warm		
BIN 22 12 Vcc	4,4	2,72	-	32,7 W	-
BIN 22 24 Vcc	18,6	1,29	-	31 W	-

Dimensions

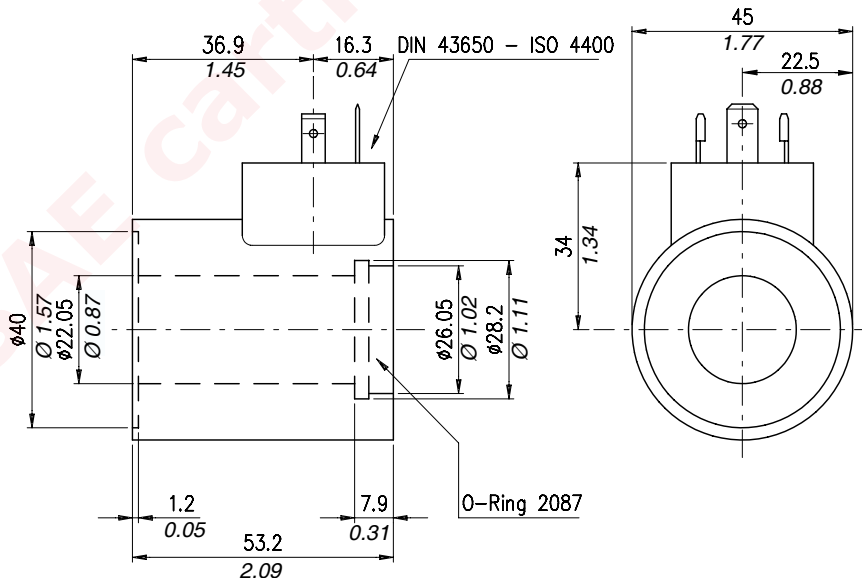

Order code

Type	Ordering code	Ordering code with standard connector	Standard connector code	Connector page
BIN 22 12 Vcc	4SL6000122	5SL6000122	4CN1009990	Page 162 CC-CA
BIN 22 24 Vcc	4SL6000241	5SL6000241		

Operation

Electric coils for tube diameter 16mm. Multiple coil versions are available to allow use with direct and alternated current.

Thermal insulation class: F(Tmax=155°C)-(VDE 0580)

Relative duty cycle: ED 100% (VDE 0580)

To assure ED=100% and perform continuous coil operation, the following conditions should be met:

$TA + \Delta T < T_{max}$

Whereas:

TA = ambient temperature

T = temperature increase due to operation

Tmax = maximum admissible temperature according to insulation class

We therefore recommend always checking that the maximum ambient temperature is same as Tmax - ΔT (providing no special operating requirement are there).

Safety standards (DIN 40050)

-IP54 without connector

-IP65 with connector

Admissible voltage range for long lasting and trouble free operations life: nominal voltage $\pm 10\%$

Performance

Type	Resistance Ω $T_A = 20^\circ C$ $68^\circ C$	Current (A)		Power (W) or (VA) Cold	ΔT	
		Cold	Warm		After 1 hour at: - $T_a = 20-25^\circ C$ $68-77^\circ F$ -Nominal voltage	
					C°	F°
BC 16 12 Vcc	5,5	2,18	1,52	26,1 W	120	248
BC 16 24 Vcc	22,2	1,08	0,75	25,9 W		
BC 16 26 RAC	26,9	0,97	0,7	25,2 W		
BC 16 24 RAC	17,8	1,21	0,84	26,1 W		
BC 16 48 RAC	72	0,6	0,42	25,9 W		
BC 16 110 RAC	369	0,265	0,19	25,9 W		
BC 16 220 RAC	1508	0,13	0,091	25,5 W		

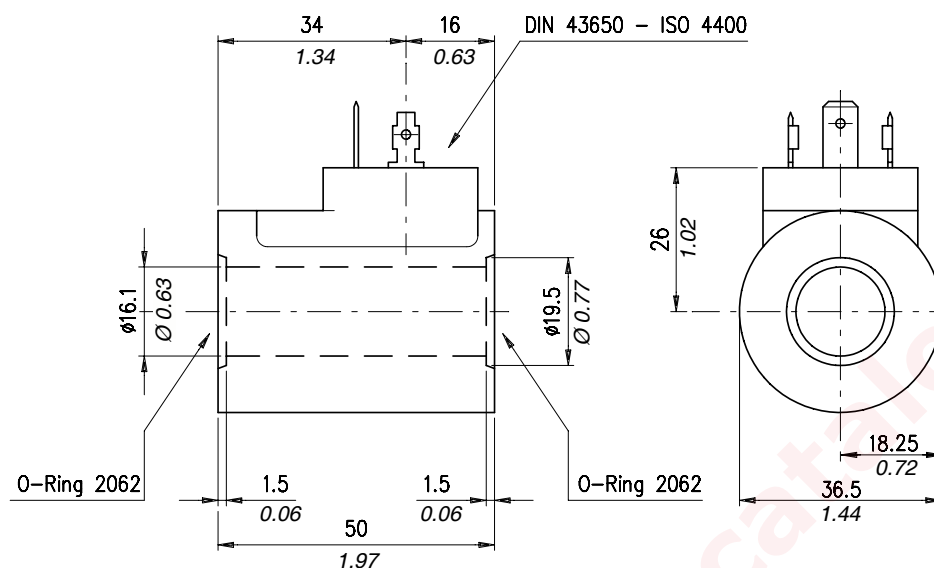

Order code

Type	Ordering code	Ordering code with standard connector	Standard connector code	Connector page
BC 16 12 Vcc	4SL8000120	5SL8000120	4CN1009990	Page 162 CC-CA
BC 16 24 Vcc	4SL8000240	5SL8000240		
BC 16 26 Vcc	4SL8000260	5SL8000260		
BC 16 24 RAC	4SL8030240	5SL8030240	4CN3010240	Page 162 CP
BC 16 48 RAC	4SL8030480	5SL8030480	4CN3010480	
BC 16 110 RAC	4SL8031100	5SL8031100	4CN3011100	
BC 16 220 RAC	4SL8032200	5SL8032200	4CN3012200	

Operation

There are 3 types of different solenoid connectors:

"CC-CA" 2-poles + GROUND electric connectors in compliance with DIN and A/ISO standards 43650 and 4400.

Electric connectors suitable for connection of DC and AC current coils. Type of current must be same as for the coil used.

"CL" 2-poles + rectifier + GROUND electric connectors in compliance with DIN and A/ISO standards 43650 and 4400.

Electric connectors suitable for connection of DC current coils BE...RAC. AC current operation only. Use of these poles depends on the type of valve used.

"CP" 2-poles + rectifier + GROUND electric connectors in compliance with DIN and A/ISO standards 43650 and 4400.

Electric connectors suitable for connection of DC current coils BT...RAC. AC current operation only. Use of these poles depends on the type of valve used.

Type	Nominal voltage	Maximum capacity of in-built diode	Nominal poles voltage	Max pole voltage	Poles resistance	Max poles section	Cable size options	Cable diameter	Safety standards	Insulation index
CC-CA	AC	-	10 A	16 A	≤ 4 m Ohm	1,5 mm ² 0.002in ²	Pg09	6-8 mm 0.24-0.31 in	IP65 (DIN 40050)	VDE0110-1/89
CL	max 250 V DC	1 A								
CP	max 300 V	3 A								

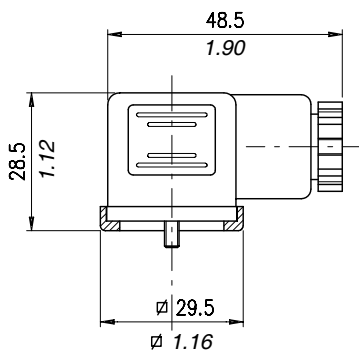

code number CC-CA Connector

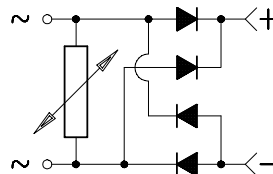
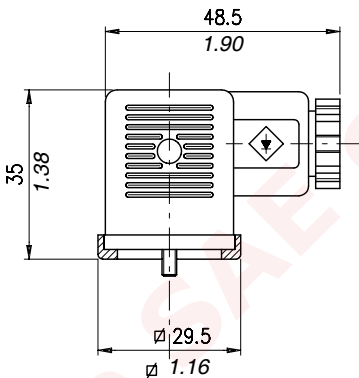

code number CL Connector

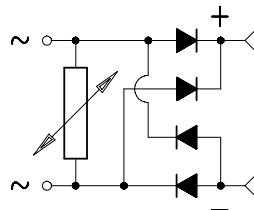
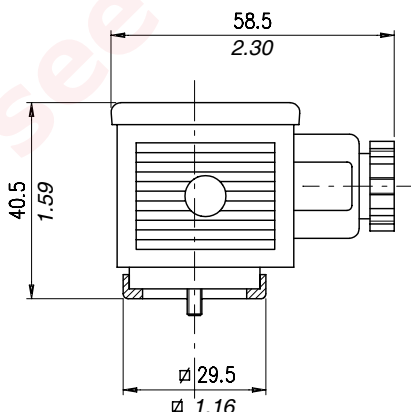

code number CP Connector

Operation

This chapter show main adjusting devices for the valves listed in this catalog.
These regulations are used to adjust flow rate between inlet and working ports.

Performance

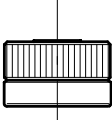
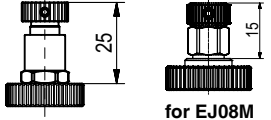
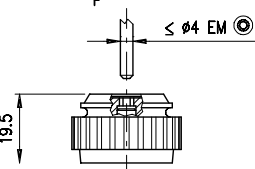
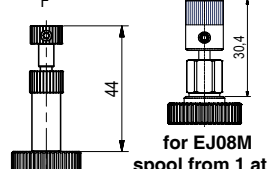
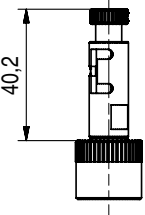
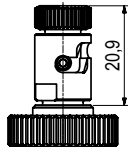
	<p>“N”</p>	 <p>for EJ08M spool from 1 at 5</p>	<p>“T”</p>
	<p>“P”</p>	 <p>for EJ08M spool from 1 at 5</p>	<p>“F”</p>
	<p>“D”</p>		<p>“Q”</p>

Dimensions

Material	Max. pressure	
	bar	psi
Alluminium	210	3050
Steel	350	5100

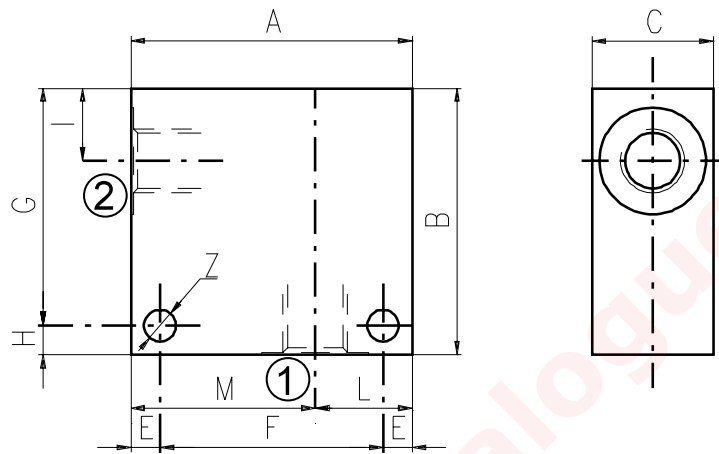

Cavità	Attacchi		A	B	C	E	F	G	H	I	L	M	Z
SAE 8/2	G 1/2	mm	70	65	35	7	56	53	12	14,5	35	35	6,5
		in	2.75	2.56	1.38	0.27	2.20	2.09	0.47	0.57	1.38	1.38	0.25
	G 1/4	mm	50	50	30	6	38	44	6	14,8	20	30	6,5
		in	1.97	1.97	1.18	0.24	1.50	1.73	0.24	0.58	0.79	1.18	0.25
	G 3/8	mm	50	50	30	6	38	44	6	14,8	20	30	6,5
		in	1.97	1.97	1.18	0.24	1.50	1.73	0.24	0.58	0.79	1.18	0.25
	SAE6	mm	50	50	30	6	38	44	6	14,8	20	30	6,5
		in	1.97	1.97	1.18	0.24	1.50	1.73	0.24	0.58	0.79	1.18	0.25
SAE 10/2	G 1/4	mm	60	60	35	6	48	54	6	18,8	25	35	6,5
		in	2.36	2.36	1.38	0.24	1.89	2.12	0.24	0.74	0.98	1.38	0.25
	G 3/8	mm	60	60	35	6	48	54	6	18,8	25	35	6,5
		in	2.36	2.36	1.38	0.24	1.89	2.12	0.24	0.74	0.98	1.38	0.25
	G 1/2	mm	60	60	35	6	48	54	6	18,8	25	35	6,5
		in	2.36	2.36	1.38	0.24	1.89	2.12	0.24	0.74	0.98	1.38	0.25
	SAE8	mm	60	70	35	6	48	64	6	18,8	25	35	6,5
		in	2.36	2.75	1.38	0.24	1.89	2.52	0.24	0.74	0.98	1.38	0.25
	SAE10	mm	70	70	35	6	58	64	6	18,5	35	35	6,5
		in	2.75	2.75	1.38	0.24	2.28	2.52	0.24	0.73	1.38	1.38	0.25
	SAE12	mm	70	70	40	8	54	62	8	22	30	40	8,5
		in	2.75	2.75	1.57	0.31	2.12	2.44	0.31	0.87	1.18	1.57	0.33
SAE 12/2	G 1/2	mm	70	80	40	8	54	72	8	25	30	40	8,5
		in	2.75	3.15	1.57	0.31	2.12	2.83	0.31	0.98	1.18	1.57	0.33
	G 3/4	mm	70	90	40	8	54	82	8	25	30	40	8,5
		in	2.75	3.54	1.57	0.31	2.12	3.23	0.31	0.98	1.18	1.57	0.33
	SAE10	mm	70	85	40	8	54	77	8	25	30	40	8,5
		in	2.75	3.35	1.57	0.31	2.12	3.03	0.31	0.98	1.18	1.57	0.33
	SAE12	mm	70	85	40	8	54	77	8	25	30	40	8,5
		in	2.75	3.35	1.57	0.31	2.12	3.03	0.31	0.98	1.18	1.57	0.33

Dimensions

Cavity	Ports	A	B	C	E	F	G	H	I	L	M	Z	
SAE 16/2	G 1/2	mm	80	90	50	10	60	80	10	25	35	45	10,5
		in	3.15	3.54	1.97	0.39	2.36	3.15	0.39	0.98	1.38	1.77	0.41
	G 3/4	mm	80	90	50	10	60	80	10	25	35	45	10,5
		in	3.15	3.54	1.97	0.39	2.36	3.15	0.39	0.98	1.38	1.77	0.41
	G 1	mm	85	100	60	10	65	90	10	23,5	40	45	10,5
		in	3.35	3.94	2.36	0.39	2.56	3.54	0.39	0.92	1.57	1.77	0.41
	SAE12	mm	80	90	50	10	60	80	10	25	35	45	10,5
		in	3.15	3.54	1.97	0.39	2.36	3.15	0.39	0.98	1.38	1.77	0.41
	SAE16	mm	80	100	50	10	60	90	10	25	35	45	10,5
		in	3.15	3.94	1.97	0.39	2.36	3.54	0.39	0.98	1.38	1.77	0.41

Order code

3/CC /- □ □ /20/□- □-1

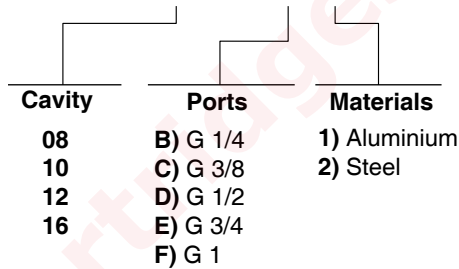

Dimensions

Material	Max. pressure	
	bar	psi
Aluminium	210	3050
Steel	350	5100

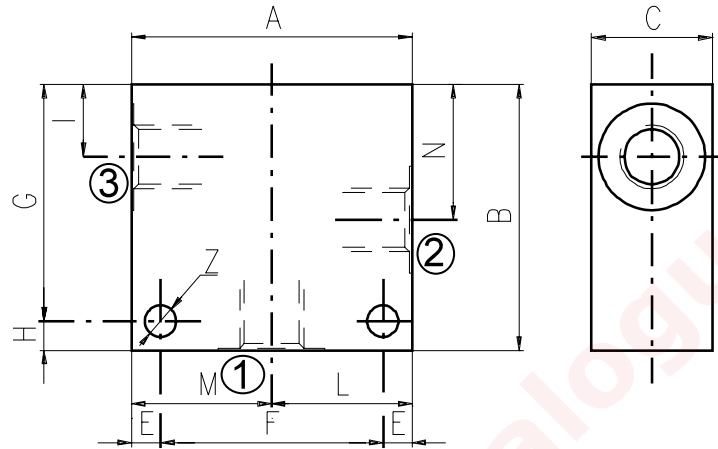

Cavity	Ports		A	B	C	E	F	G	H	I	L	M	N	Z
SAE 8/3	G 1/4	mm	60	60	30	7	46	48	12	14,8	30	30	29,1	6,5
		in	2.36	2.36	1.18	0.27	1.81	1.89	0.47	0.58	1.18	1.18	1.14	0.25
	G 3/8	mm	60	60	30	7	46	48	12	14,5	30	30	29,1	6,5
		in	2.36	2.36	1.18	0.27	1.81	1.89	0.47	0.57	1.18	1.18	1.14	0.25
	G 1/2	mm	70	65	35	7	56	53	12	14,5	35	35	29,1	6,5
		in	2.75	2.56	1.38	0.27	2.20	2.09	0.47	0.57	1.38	1.38	1.14	0.25
SAE6	mm	60	60	30	7	46	48	12	14,5	30	30	29,1	6,5	
	in	2.36	2.36	1.18	0.27	1.81	1.89	0.47	0.57	1.18	1.18	1.14	0.25	
SAE 10/3	G 1/4	mm	60	65	35	6	48	59	6	18	30	30	34,5	7
		in	2.36	2.56	1.38	0.24	1.89	2.32	0.24	0.70	1.18	1.18	1.36	0.27
	G 3/8	mm	60	65	35	6	48	59	6	18,8	30	30	34,5	7
		in	2.36	2.56	1.38	0.24	1.89	2.32	0.24	0.74	1.18	1.18	1.36	0.27
	G 1/2	mm	65	70	35	6	53	64	6	18,8	32,5	32,5	34,5	7
		in	2.56	2.75	1.38	0.24	2.09	2.52	0.24	0.74	1.28	1.28	1.36	0.27
	SAE6	mm	65	70	35	6	53	64	6	18,8	32,5	32,5	34,5	7
		in	2.56	2.75	1.38	0.24	2.09	2.52	0.24	0.74	1.28	1.28	1.36	0.27
	SAE8	mm	65	70	35	6	53	64	6	18,8	32,5	32,5	34,5	7
		in	2.56	2.75	1.38	0.24	2.09	2.52	0.24	0.74	1.28	1.28	1.36	0.27
SAE 12/3	G 1/2	mm	70	100	40	8	54	92	8	25	35	35	53,5	8,5
		in	2.75	3.94	1.57	0.31	2.12	3.6	0.31	0.98	1.38	1.38	2.10	0.33
	G 3/4	mm	90	100	50	10	70	90	10	25,1	45	45	53,5	10,5
		in	3.54	3.94	1.97	0.39	2.75	3.54	0.39	0.99	1.77	1.77	2.11	0.41
	SAE10	mm	80	100	40	8	64	92	8	25	40	40	53,5	8,5
		in	3.15	3.94	1.57	0.31	2.52	3.6	0.31	0.98	1.57	1.57	2.11	0.33
	SAE12	mm	80	100	45	8	64	92	8	25	40	40	53,5	8,5
		in	3.15	3.94	1.77	0.31	2.52	3.6	0.31	0.98	1.57	1.57	2.11	0.33

Dimensions

Cavity	Ports	A	B	C	E	F	G	H	I	L	M	N	Z	
SAE 16/3	G 3/4	mm	90	100	50	10	70	90	10	25,1	45	45	53,5	10,5
		in	3.54	3.94	1.97	0.39	2.75	3.54	0.39	0.99	1.77	1.77	2.11	0.41
	SAE12	mm	90	105	50	10	70	95	10	25,1	45	45	53,5	10,5
		in	3.54	4.13	1.97	0.39	2.75	3.74	0.39	0.99	1.77	1.77	2.11	0.41
	SAE16	mm	90	105	50	10	70	95	10	25,1	45	45	53,5	10,5
		in	3.54	4.13	1.97	0.39	2.75	3.74	0.39	0.99	1.77	1.77	2.11	0.41

Order code

3/CC /- □ □ /30/□- □-1

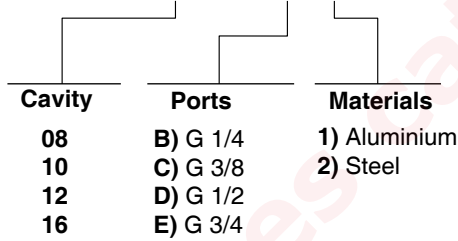

Dimensions

Material	Max. pressure	
	bar	psi
Aluminium	210	3050
Steel	350	5100

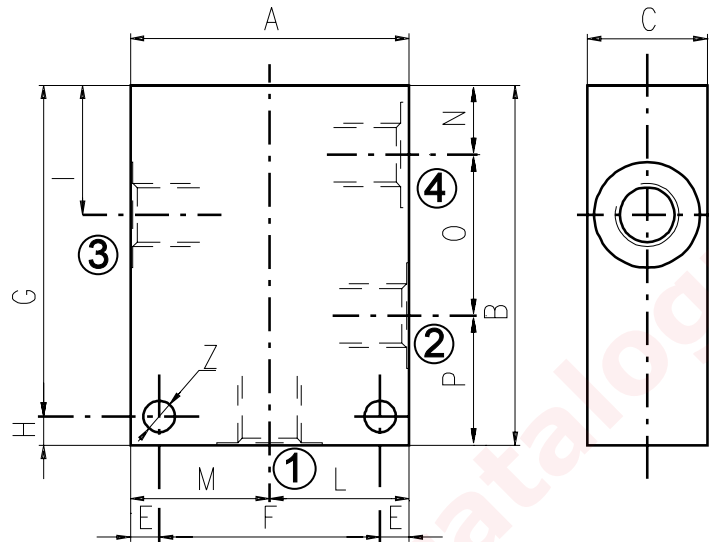

Cavity	Ports		A	B	C	E	F	G	H	I	L	M	N	O	P	Z
SAE 8/4	G 1/4	mm	60	75	30	7	46	63	12	29,1	30	30	14,8	29,1	31,1	6,5
		in	2.36	2.95	1.18	0.27	1.81	2.48	0.47	1.14	1.18	1.18	0.58	1.14	1.22	0.25
	SAE6	mm	60	75	30	7	46	63	12	29,1	30	30	14,8	29,1	31,1	6,5
		in	2.36	2.95	1.18	0.27	1.81	2.48	0.47	1.14	1.18	1.18	0.58	1.14	1.22	0.25
SAE 10/4	G 3/8	mm	60	85	35	6	48	79	6	34,5	30	30	18,8	31,7	34,5	7
		in	2.36	3.35	1.38	0.24	1.89	3.11	0.24	1.36	1.18	1.18	0.74	1.25	1.36	0.27
	G 1/2	mm	70	85	35	6	58	79	6	34,5	35	35	18,8	31,7	34,5	7
		in	2.75	3.35	1.38	0.24	2.28	3.11	0.24	1.36	1.38	1.38	0.74	1.25	1.36	0.27
	SAE6	mm	60	85	35	6	48	79	6	34,5	30	30	18,8	31,7	34,5	7
		in	2.36	3.35	1.38	0.24	1.89	3.11	0.24	1.36	1.18	1.18	0.74	1.25	1.36	0.27
SAE8	mm	70	85	35	6	58	79	6	34,5	35	35	18,8	31,7	34,5	7	
	in	2.75	3.35	1.38	0.24	2.28	3.11	0.24	1.36	1.38	1.38	0.74	1.25	1.36	0.27	
SAE 12/4	G 1/2	mm	80	115	40	8	64	107	8	44	40	40	22	44,5	48,5	8,5
		in	3.15	4.53	1.57	0.31	2.52	4.21	0.31	1.73	1.57	1.57	0.87	1.75	1.9	0.33
	SAE10	mm	80	115	40	8	64	107	8	44	40	40	22	44,5	48,5	8,5
		in	3.15	4.53	1.57	0.31	2.52	4.21	0.31	1.73	1.57	1.57	0.87	1.75	1.9	0.33
SAE 16/4	G 3/4	mm	100	130	50	10	80	120	10	53,5	50	50	25,1	56,9	48	10,5
		in	3.94	5.12	1.97	0.39	3.15	4.72	0.39	2.11	1.97	1.97	0.99	2.24	1.89	0.41

3/CC /- □ □ /40/□- □-1

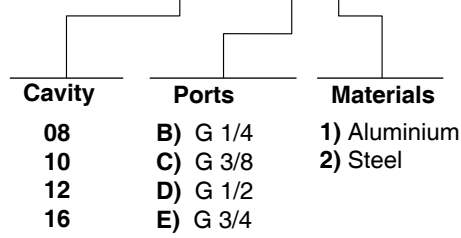

see SAE cartridges catalogue

Informations

How to order valves with body

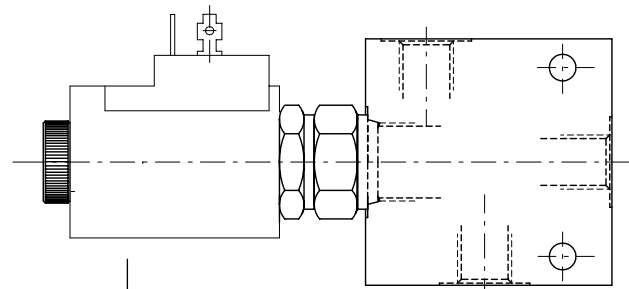

CARTRIDGE CODE

EJ-08A/10NB

BILLET CODE

B- 1-1

Cavity	Ports	Materials
08	B) G 1/4	1) Aluminium
10	C) G 3/8	
12	D) G 1/2	
16	E) G 3/4	
	F) G 1	
	J) SAE 6	2) Steel
	K) SAE 8	
	L) SAE 10	
	M) SAE 12	
	N) SAE 16	

VARIATION "A": the dimensions with "*" are related to the variation "A". Features of variation "A" are required only if noted on specific product catalogue page.

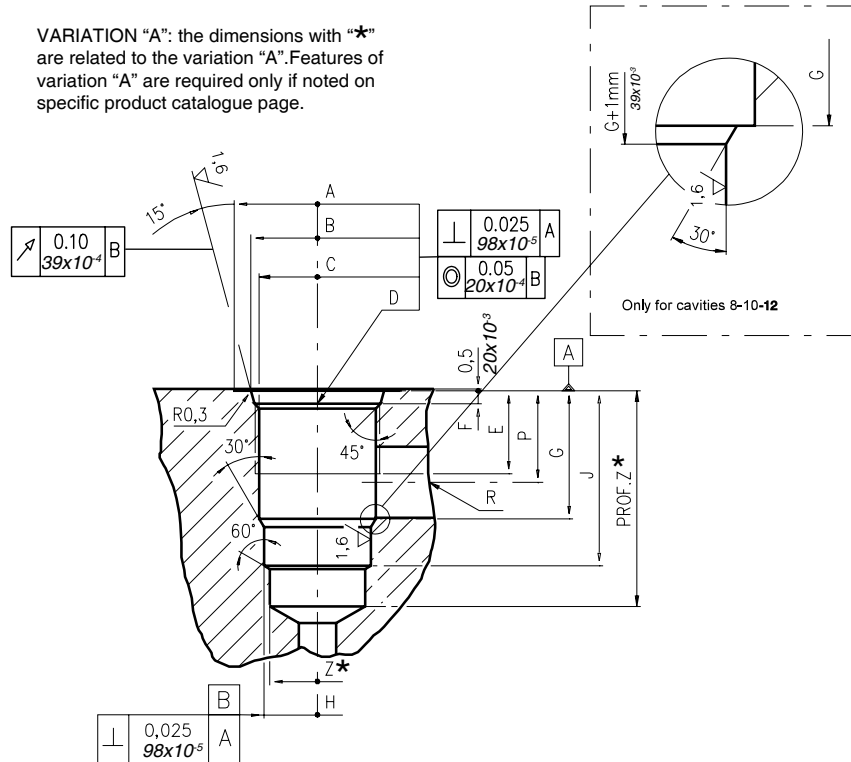

Cavity	A	B ±0,05	C ±0,05	D	E	F	G	H ±0,02	J	K ±0,02	L	M ±0,02	N	P	R øMAX	S øMAX	T øMAX	U øMAX	V øMAX	X øMAX	Z * øMIN	Prof. * MIN	
																							mm
08/2	mm	27	20,66	17,42	3/4-16 UNF	12,50	2,50	18,20	12,72	29,50	-	-	-	-	14,00	8,00	-	-	-	-	-	12,00	39
	in	1.06	0.81	0.68		0.49	0.10	0.72	0.50	1.16	-	-	-	-	0.55	0.31	-	-	-	-	-	0.47	1.53
10/2	mm	30	24,00	20,62	7/8-14 UNF	16,00	2,80	24,00	15,90	33,50	-	-	-	-	18,30	11,00	-	-	-	-	-	14,50	40
	in	1.18	0.94	0.81		0.63	0.11	0.94	0.62	1.32	-	-	-	-	0.72	0.43	-	-	-	-	-	0.57	1.57
12/2	mm	38	29,23	24,73	1 1/16-12 UNF	19,00	3,50	34,15	22,25	46,80	-	-	-	-	24,50	19,00	-	-	-	-	-	21,50	60
	in	1.50	1.15	0.97		0.75	0.14	1.34	0.87	1.84	-	-	-	-	0.96	0.75	-	-	-	-	-	0.85	2.36
16/2	mm	45	35,58	31,34	1 5/16-12 UNF	22,00	3,50	34,00	28,62	47,00	-	-	-	-	24,50	19,00	-	-	-	-	-	25,50	70
	in	1.77	1.40	1.23		0.87	0.14	1.34	1.13	1.85	-	-	-	-	0.96	0.75	-	-	-	-	-	1.00	2.75

Rougher tool

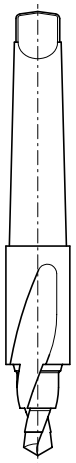

Cavity	Code number
08/2	3UT03416UNF
10/2	3UT07814UNF
12/2	3UT0111612UN
16/2	3UT0151612UN

Finisher tool

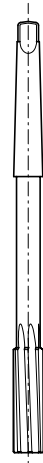

Cavity	Code number
08/2	3UT00053190
10/2	3UT00056610
12/2	3UT00054090
16/2	3UT00054510

Tap

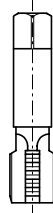

Cavity	Code number
08/2	3UT06A1270N
10/2	3UT00054580
12/2	3UT00054670
16/2	3UT00054520

Cavity plugs

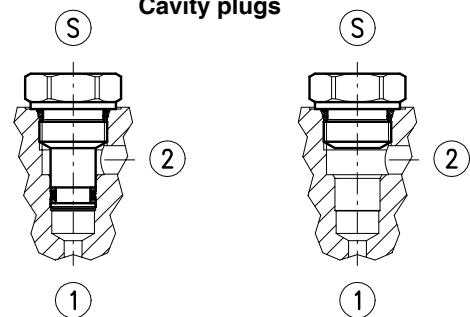

Cavity	Code number	①	②	Ⓢ
08/2	3XTP3533700	X	X	X
	4TP5531500	0	0	X
10/2	3XTP3544200	X	X	X
	3XTP1542300	0	0	X
12/2	3XTP3555400	X	X	X
	3XTP1552900	0	0	X
16/2	3XTP3575500	X	X	X
	3XTP1572900	0	0	X

X=Closed 0=Open

Dimensions

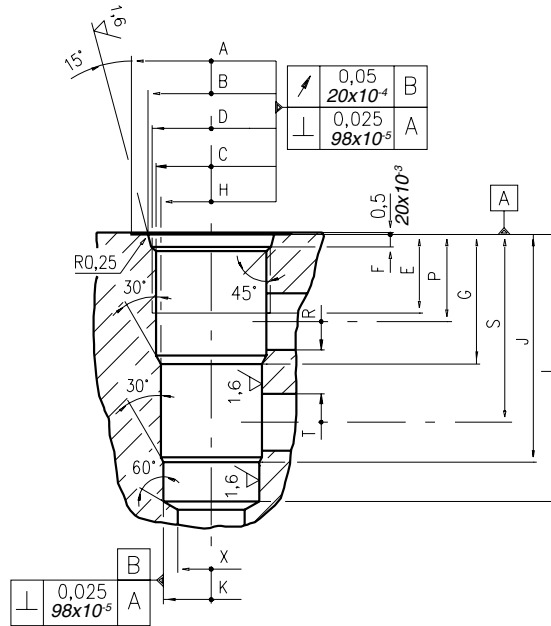

\	A	B ±0,05	C ±0,05	D	E	F	G	H ±0,02	J	K ±0,02	L	M ±0,02	N	P	R øMAX	S	T øMAX	U	V øMAX	X øMAX	Z øMIN	Prof. Z MIN	
08/3	mm	27	20,66	17,42	3/4-16 UNF	12,50	2,5	19,10	15,90	33,30	14,30	43,30	-	-	14,30	5,50	28,60	5,50	-	-	12,50	-	-
	in	1.06	0.81	0.68		0.49	0.10	0.75	0.62	1.31	0.56	1.70			0.56	0.22	1.12	0.22			0.49		
10/3	mm	30	24,00	20,62	7/8-14 UNF	16,00	2,80	23,10	17,50	39,60	15,90	47,60	-	-	18,30	6,50	34,00	6,50	-	-	14,00	-	-
	in	1.18	0.94	0.81		0.63	0.11	0.94	0.69	1.56	0.62	1.87			0.72	0.25	1.34	0.25			0.55		
12/3	mm	38	29,23	24,73	1 1/16-12 UNF	19,00	3,56	36,60	23,82	63,50	22,25	75,40	-	-	24,50	16,00	53,00	16,00	-	-	19,00	-	-
	in	1.50	1.15	0.97		0.75	0.14	1.44	0.94	2.5	0.88	2.97			0.96	0.63	2.09	0.63			0.75		
16/3	mm	45	35,6	31,34	1 5/16-12 UNF	22,00	3,5	36,50	28,62	64,30	27,02	75,38	-	-	24,60	16,00	53,00	16,00	-	-	19,00	-	-
	in	1.77	1.40	1.23		0.87	0.14	1.44	1.13	2.53	1.06	2.97			0.97	0.63	2.09	0.63			0.75		

Rougher tool

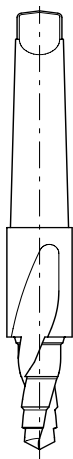

Cavity	Code number
08/3	3UT00052190
10/3	3UT00054170
12/3	3UT00054290
16/3	3UT00054470

Finisher tool



Cavity	Code number
08/3	3UT00052740
10/3	3UT00054180
12/3	3UT00054300
16/3	3UT00054480

Tap



Cavity	Code number
08/3	3UT03416UNF
10/3	3UT07814UNF
12/3	3UT0111612UN
16/3	3UT0151612UN

Cavity plugs

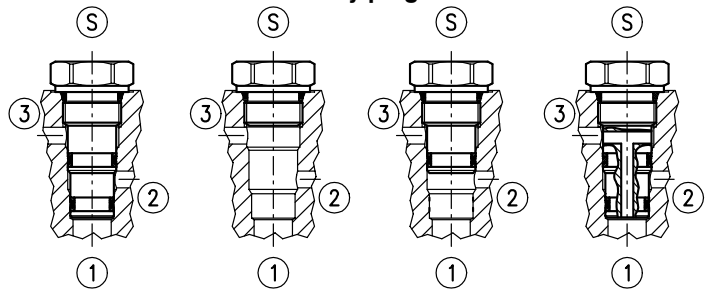

Cavity	Code number	①	②	③	Ⓢ
08/3	3XTP3535100	X	X	X	X
	4TP5531500	0	0	0	X
	3XTP3534000	0	0	X	X
	3XTP3534800	0	X	0	X
10/3	3XTP3545700	X	X	X	X
	3XTP1542300	0	0	0	X
	3XTP3545701	0	X	0	X
12/3	3XTP3558200	X	X	X	X
	3XTP1552900	0	0	0	X
	3XTP3558201	0	X	0	X
16/3	3XTP3578400	X	X	X	X
	3XTP1572900	0	0	0	X

X=Closed 0=Open

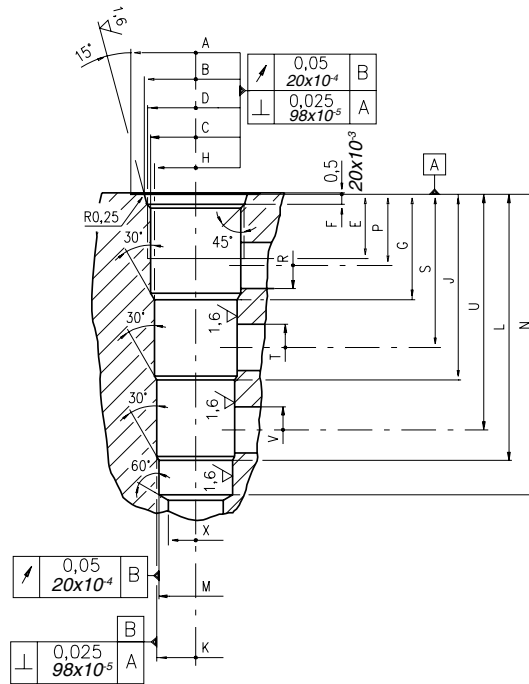

\		A	B ±0,05	C ±0,05	D	E	F	G	H ±0,02	J	K ±0,02	L	M ±0,02	N	P	R øMAX	S	T øMAX	U	V øMAX	X øMAX	Z ø MIN	Prof. Z MIN
		08/4	mm	28,00		20,66	17,42	3/4-16 UNF	12,50	2,50	19,10	15,90	33,30	14,30	47,60	12,72	57,60	14,30	5,50	28,60	5,50	42,90	5,50
	in	1.10	0.81	0.68		0.49	0.10		0.75	0.62	1.31	0.56	1.87	0.50	2.27	0.56	0.22	1.12	0.22	1.69	0.22	0.43	-
10/4	mm	30	24,00	20,62	7/8-14 UNF	16,00	2,80	23,60	19,08	39,60	17,50	55,40	15,90	63,50	18,30	6,50	34,00	6,50	50,00	6,50	14,00	-	-
		in	1.18	0.94		0.81		0.63	0.11	0.93	0.75	1.56	0.69	2.18	0.62	2.50	0.72	0.26	1.34	0.25	1.97	0.25	0.55
12/4	mm	38	29,23	24,73	1 1/16-12 UNF	19,00	3,56	29,50	23,82	51,50	22,25	73,60	20,65	83,33	21,50	11,00	43,50	11,00	66,00	11,00	19,00	-	-
		in	1.50	1.15		0.97		0.75	0.14	1.16	0.94	2.03	0.87	2.90	0.81	3.28	0.85	0.43	1.71	0.43	2.60	0.43	0.75
16/4	mm	45	35,60	31,34	1 5/16-12 UNF	22,00	3,50	36,50	28,62	64,30	27,02	92,07	25,45	104,00	24,60	16,00	53,00	16,00	81,50	16,00	19,00	-	-
		in	1.77	1.40		1.23		0.87	0.14	1.44	1.13	2.53	1.06	3.62	1.00	4.09	0.97	0.63	2.09	0.63	3.21	0.63	0.75

Rougher tool

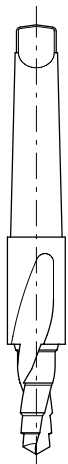

Cavity	Code number
08/4	3UT00052040
10/4	3UT00054250
12/4	3UT00054410
16/4	3UT00054820

Finisher



Cavity	Code number
08/4	3UT00052020
10/4	3UT00054260
12/4	3UT00054420
16/4	3UT00054830

Tap



Cavity	Code number
08/4	3UT03416UNF
10/4	3UT07814UNF
12/4	3UT111612UN
16/4	3UT0151612UN

Cavity plugs

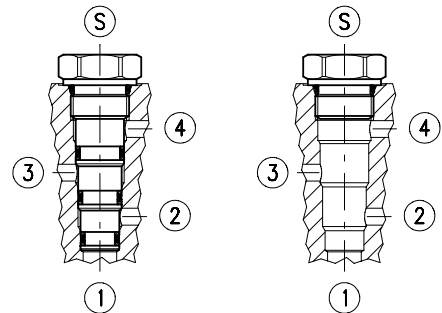

Cavity	Code number	①	②	③	④	Ⓢ
08/4	3XTP3536500	X	X	X	X	X
	4TP5531500	0	0	0	0	X
10/4	3XTP3548301	X	X	X	X	X
	3XTP1542300	0	0	0	0	X
12/4	3XTP3559300	X	X	X	X	X
	3XTP1552900	0	0	0	0	X
16/4	3XTP357B300	X	X	X	X	X
	3XTP1572900	0	0	0	0	X

X=Closed 0=Open

Dimensions

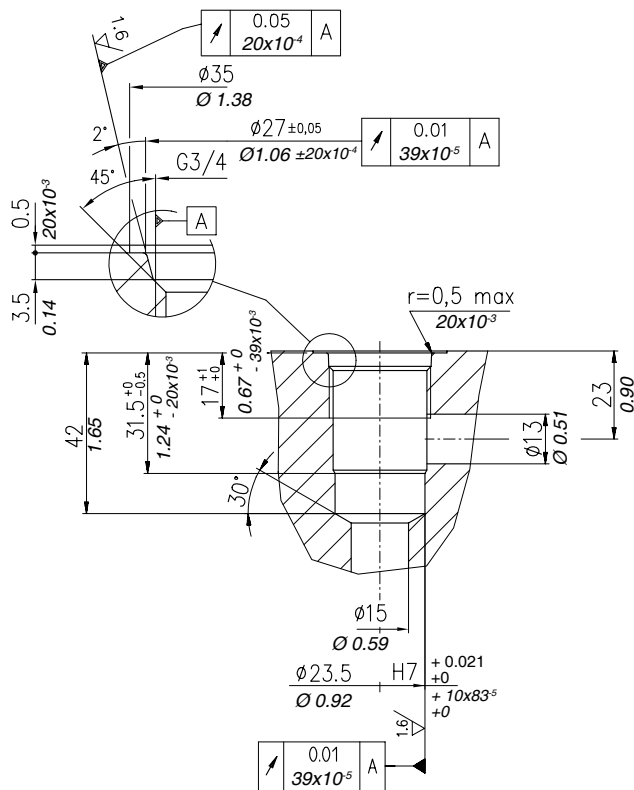

Rougher tool
Cod.3UT00052300

Finisher
Cod.3UT00055020

Tap
Cod.3UT09A34F14G

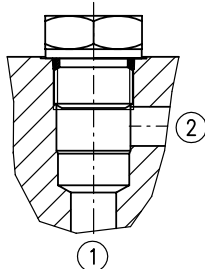
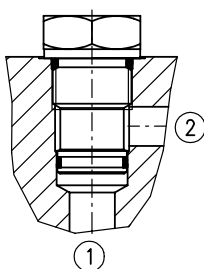
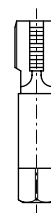
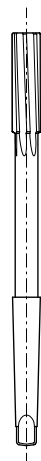
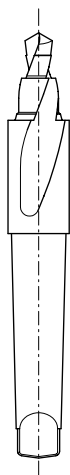

X = Closed ; 0 = Open

Code number	(1)	(2)
3XTP3145100	X	X
3XTP5142001	0	0

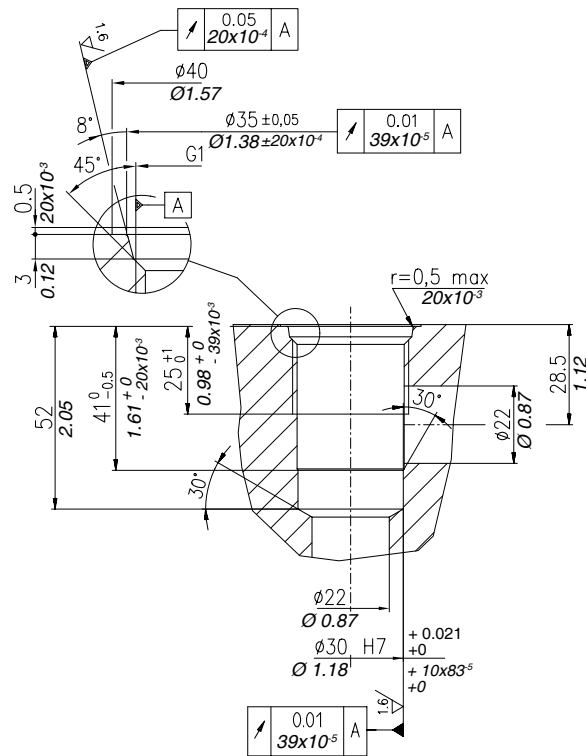

Rougher tool
Cod.3UT00050870A

Finisher tool
Cod.3UTO6A3000N

Tap
Cod.3UT09A10F11G

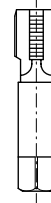
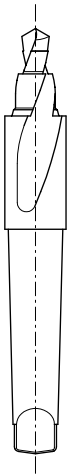

1st edition May 2010

WWW.WALVOIL.COM

 **walvoil**
HYDRAULIC CONTROL SYSTEMS

D1WWES01E

